

'COLOUR SIDE'

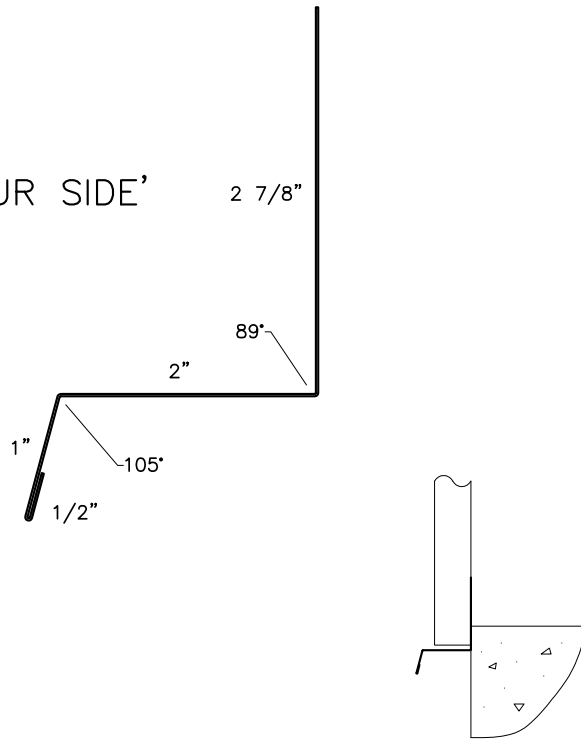

GIRTH: 6 3/8"

GAUGE	WEIGHT
29	0.32#/FT.
28	0.36#/FT.
26	0.42#/FT.
24	0.55#/FT.

exsteel BUILDING COMPONENTS		7825 Springwater Road Aylmer, Ontario N5H 2R4 519 - 765 - 2244 www.exsteel.com	
DATE:	JAN 23/1990	DRAWN:	BVERN
DATE:		CHECKED:	
DATE:		PROG:	
DATE:		ISSUED:	

DESCRIPTION:
BASE TRIM - 1 1/2" PANEL - C.O.S.

REV	DESCRIPTION	DATE	BY
1	GENERAL DETAIL REVIEW	JAN 01/09	BJD

DRAWING # **M04**

'COLOUR SIDE'

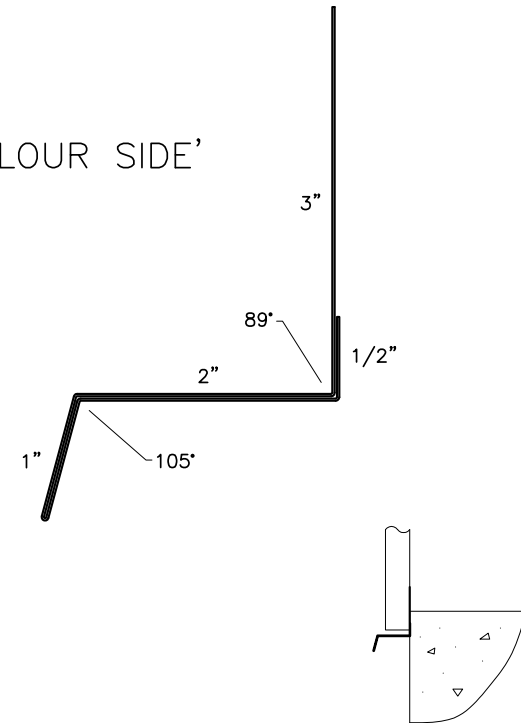

GIRTH: 9 1/2"

GAUGE	WEIGHT
29	0.52#/FT.
28	0.50#/FT.
26	0.60#/FT.
24	0.80#/FT.

exsteel BUILDING COMPONENTS		7825 Springwater Road Aylmer, Ontario N5H 2R4 519 - 765 - 2244 www.exsteel.com	
DATE:	JAN 26/1990	DRAWN:	BVERN
DATE:		CHECKED:	
DATE:		PROG:	
DATE:		ISSUED:	

DESCRIPTION:
BASE TRIM - 1 1/2" PANEL - C.B.S.

2	EXTRA MATERIAL REMOVED	JAN 11/11	AF
1	GENERAL DETAIL REVIEW	JAN 01/09	BJD

DRAWING # **M30**

'COLOUR SIDE'

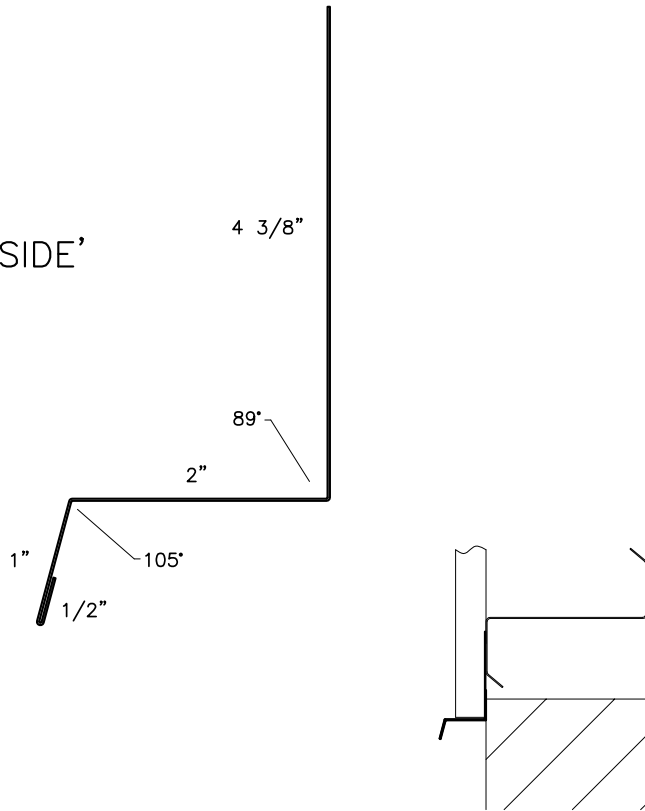

GIRTH: 7 7/8"

GAUGE	WEIGHT
29	0.37#/FT.
28	0.41#/FT.
26	0.49#/FT.
24	0.66#/FT.

		7825 Springwater Road Aylmer, Ontario N5H 2R4 519 - 765 - 2244 www.exsteel.com	
		DATE: AUG 15/2002	DRAWN: SB
DATE:		CHECKED:	
DATE:		PROG:	
DATE:		ISSUED:	
DESCRIPTION: BASE TRIM - 1 1/2" PANEL - C.O.S. - HIGH BACK			
DRAWING #		M132	

REV	DESCRIPTION	DATE	BY
1	GENERAL DETAIL REVIEW	JAN 01/09	BJD

'COLOUR SIDE'

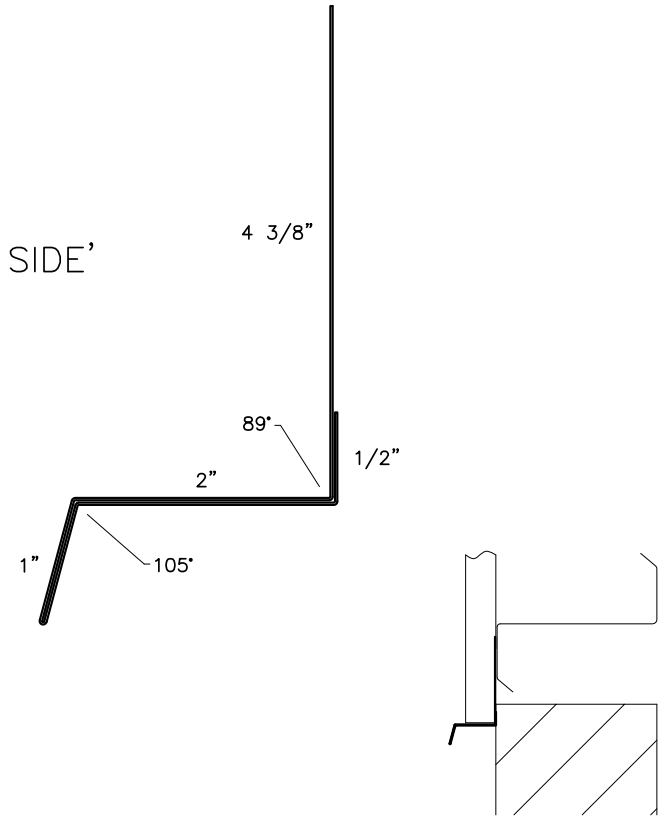

GIRTH: 10 7/8"

GAUGE	WEIGHT
29	0.59#/FT.
28	0.57#/FT.
26	0.68#/FT.
24	0.91#/FT.

		7825 Springwater Road Aylmer, Ontario N5H 2R4 519 - 765 - 2244 www.exsteel.com	
		DATE: MAR 19/2001	DRAWN: MAG
DATE:		CHECKED:	
DATE:		PROG:	
DATE:		ISSUED:	
DESCRIPTION: BASE TRIM - 1 1/2" PANEL - C.B.S. - HIGH BACK			
DRAWING #		M124	

REV	DESCRIPTION	DATE	BY
2	EXTRA MATERIAL REMOVED	JAN 11/11	AF
1	GENERAL DETAIL REVIEW	JAN 01/09	BJD

'COLOUR SIDE'

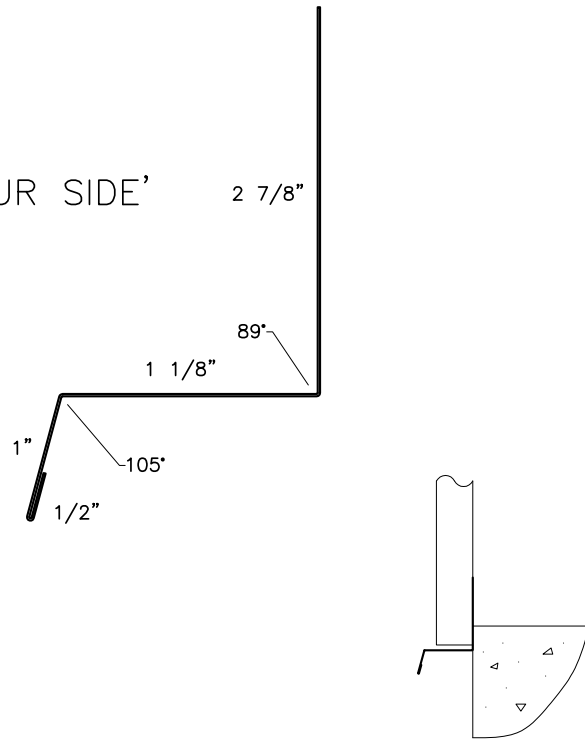

GIRTH: 5 1/2"

GAUGE	WEIGHT
29	0.30#/FT.
28	0.29#/FT.
26	0.35#/FT.
24	0.46#/FT.

exsteel BUILDING COMPONENTS		7825 Springwater Road Aylmer, Ontario N5H 2R4 519 - 765 - 2244 www.exsteel.com	
DATE:	MAR 28/2006	DRAWN:	SB
DATE:		CHECKED:	
DATE:		PROG:	
DATE:		ISSUED:	
DESCRIPTION: BASE TRIM - 5/8"-3/4" PANEL - C.O.S.			
DRAWING #		M141	

REV	DESCRIPTION	DATE	BY
2	REVISED DIMENSION	JAN 11/11	AF
1	GENERAL DETAIL REVIEW	JAN 01/09	BJD

'COLOUR SIDE'

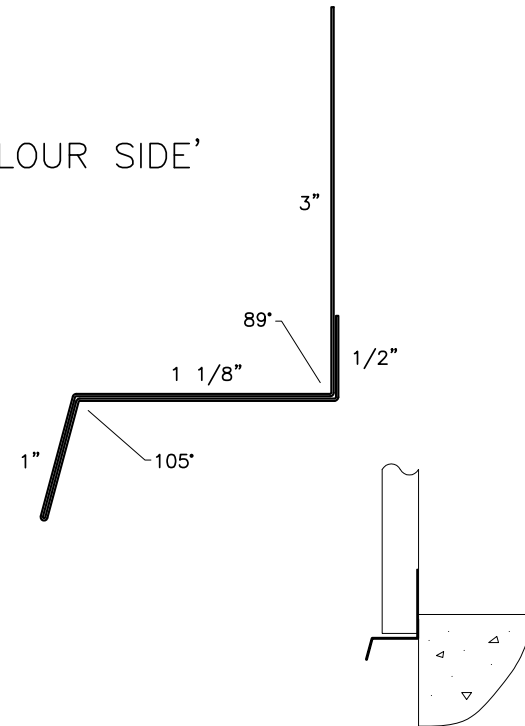

GIRTH: 7 3/4"

GAUGE	WEIGHT
29	0.42#/FT.
28	0.41#/FT.
26	0.49#/FT.
24	0.65#/FT.

exsteel BUILDING COMPONENTS		7825 Springwater Road Aylmer, Ontario N5H 2R4 519 - 765 - 2244 www.exsteel.com	
DATE:	MAR 28/2006	DRAWN:	SB
DATE:		CHECKED:	
DATE:		PROG:	
DATE:		ISSUED:	
DESCRIPTION: BASE TRIM - 5/8"-3/4" PANEL - C.B.S.			
DRAWING #		M148	

REV	DESCRIPTION	DATE	BY
2	EXTRA MAT'L REMOVED/DIM'S REV.	JAN 18/11	AF
1	GENERAL DETAIL REVIEW	JAN 01/09	BJD

'COLOUR SIDE'

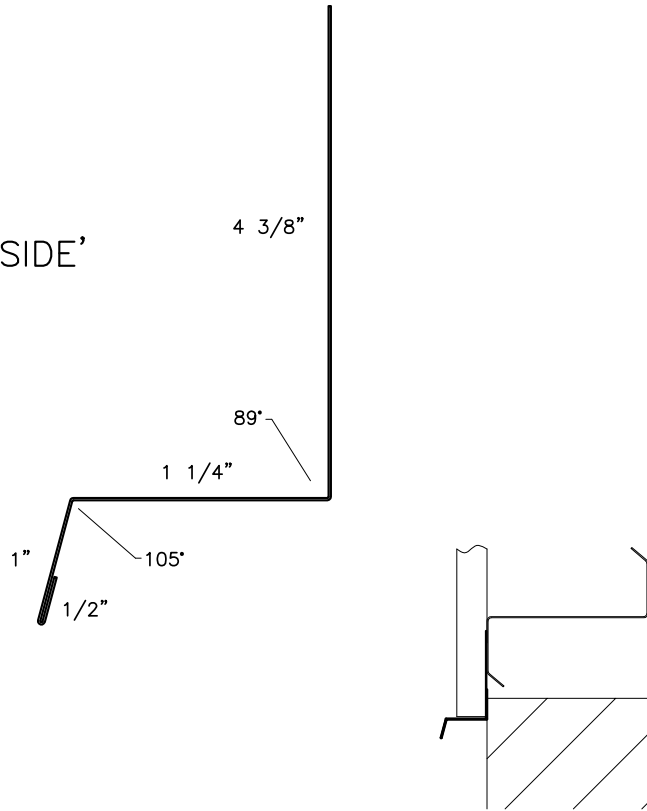

GIRTH: 7 1/8"

GAUGE	WEIGHT
29	0.33#/FT.
28	0.37#/FT.
26	0.44#/FT.
24	0.60#/FT.

exsteel BUILDING COMPONENTS		7825 Springwater Road Aylmer, Ontario N5H 2R4 519 - 765 - 2244 www.exsteel.com	
DATE:	MAR 28/2006	DRAWN:	SB
DATE:		CHECKED:	
DATE:		PROG:	
DATE:		ISSUED:	
DESCRIPTION: BASE TRIM - 5/8"-3/4" PANEL - C.O.S. - HIGH BACK			
DRAWING #		M157	
REV	DESCRIPTION	DATE	BY
1	GENERAL DETAIL REVIEW	JAN 01/09	BJD

'COLOUR SIDE'

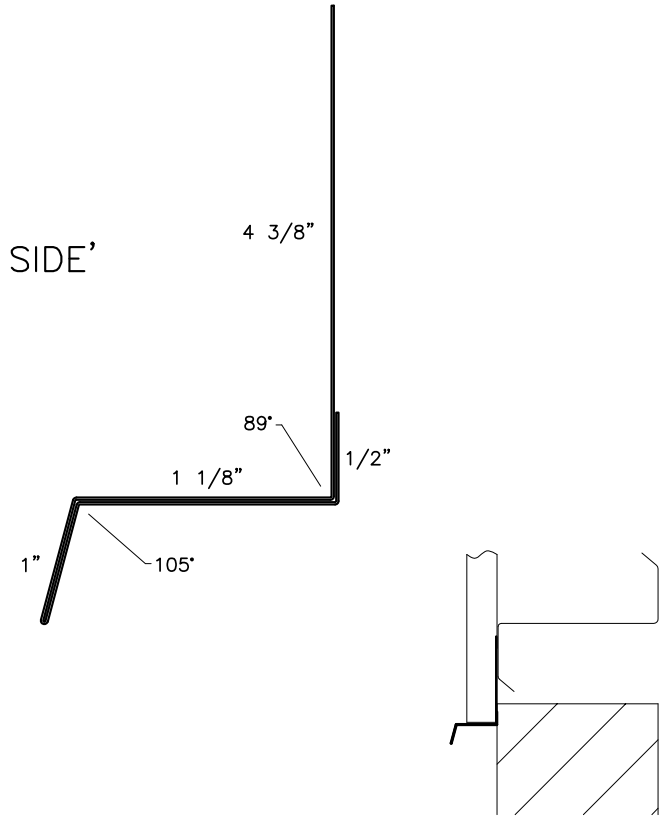

GIRTH: 9 1/8"

GAUGE	WEIGHT
29	0.50#/FT.
28	0.48#/FT.
26	0.58#/FT.
24	0.77#/FT.

exsteel BUILDING COMPONENTS		7825 Springwater Road Aylmer, Ontario N5H 2R4 519 - 765 - 2244 www.exsteel.com	
DATE:	MAR 28/2006	DRAWN:	SB
DATE:		CHECKED:	
DATE:		PROG:	
DATE:		ISSUED:	
DESCRIPTION: BASE TRIM - 5/8"-3/4" PANEL - C.B.S. - HIGH BACK			
DRAWING #		M155	
REV	DESCRIPTION	DATE	BY
2	EXTRA MAT'L REMOVED/DIM'S REV.	JAN 20/11	AF
1	GENERAL DETAIL REVIEW	JAN 01/09	BJD

'COLOUR SIDE'

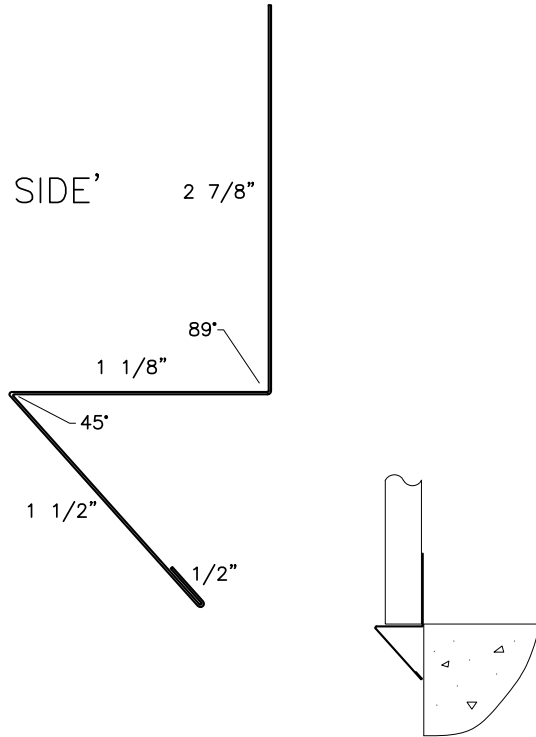

GIRTH: 6"

GAUGE	WEIGHT
29	0.33#/FT.
28	0.32#/FT.
26	0.38#/FT.
24	0.50#/FT.

		7825 Springwater Road Aylmer, Ontario N5H 2R4 519 - 765 - 2244 www.exsteel.com	
		DATE: NOV 23/2010	DRAWN: LD
DATE:		CHECKED:	
DATE:		PROG:	
DATE:		ISSUED:	
DESCRIPTION: BASE TRIM - RAT GUARD 5/8"-3/4" PANEL - C.O.S.			
DRAWING #		M248	

REV	DESCRIPTION	DATE	BY
1	GENERAL DETAIL REVIEW	MAR 14/11	AF

'COLOUR SIDE'

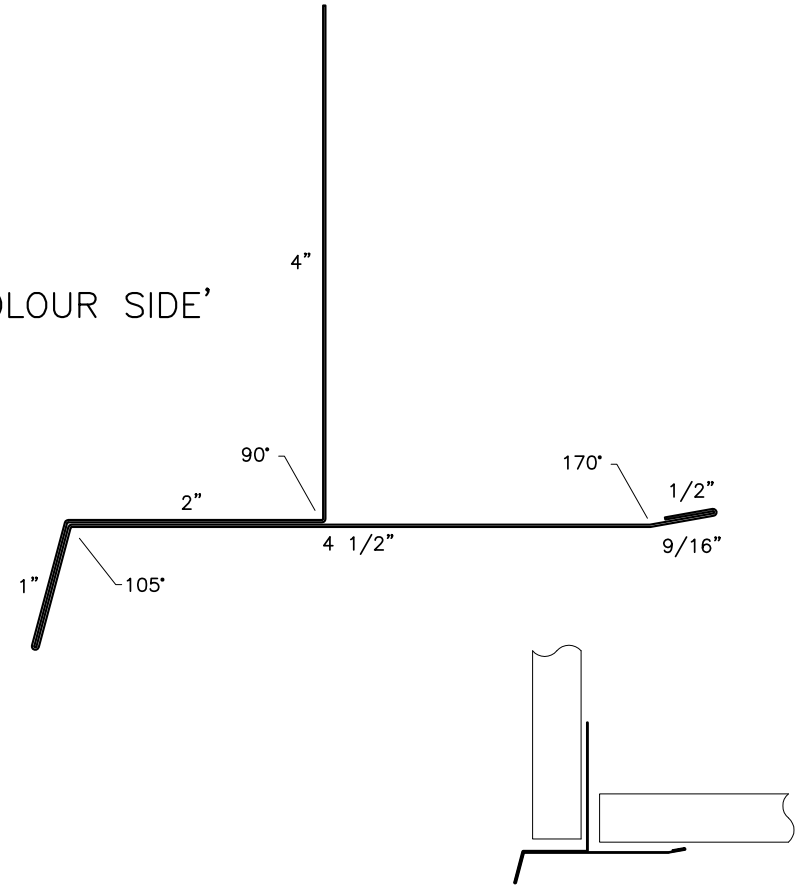

GIRTH: 13 9/16"

GAUGE	WEIGHT
29	0.64#/FT.
28	0.78#/FT.
26	0.91#/FT.
24	1.17#/FT.

		7825 Springwater Road Aylmer, Ontario N5H 2R4 519 - 765 - 2244 www.exsteel.com	
		DATE: FEB 13/1990	DRAWN: BVERN
DATE:		CHECKED:	
DATE:		PROG:	
DATE:		ISSUED:	
DESCRIPTION: DRIP TRIM - MANSARD - 1 1/2" PANEL			
DRAWING #		M27	

REV	DESCRIPTION	DATE	BY
1	GENERAL DETAIL REVIEW	JAN 01/09	BJD

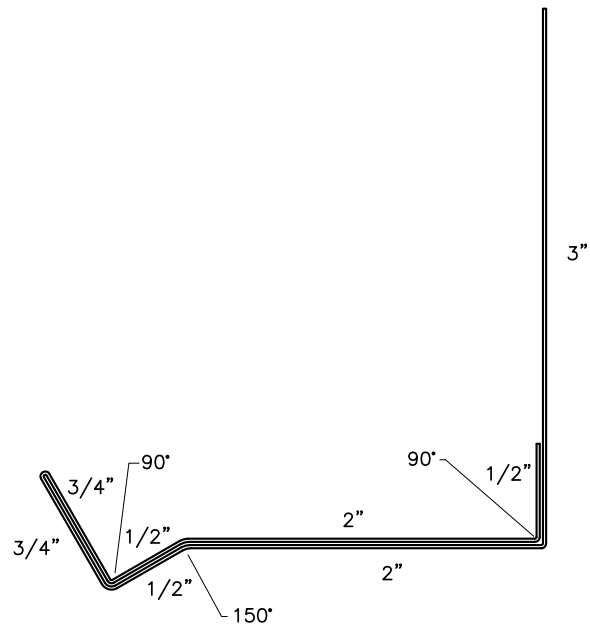

'COLOUR SIDE'

GIRTH: 10"

GAUGE	WEIGHT
29	0.45#/FT.
28	0.52#/FT.
26	0.63#/FT.
24	0.83#/FT.

exsteel BUILDING COMPONENTS		7825 Springwater Road Aylmer, Ontario N5H 2R4 519 - 765 - 2244 www.exsteel.com	
DATE:	NOV 24/2000	DRAWN:	IMO
DATE:		CHECKED:	
DATE:		PROG:	
DATE:		ISSUED:	
DESCRIPTION: DRIP TRIM - HEADER - 1 1/2" PANEL - C.B.S.			
DRAWING #		M112	
1	GENERAL DETAIL REVIEW	JAN 01/09	BJD
REV	DESCRIPTION	DATE	BY

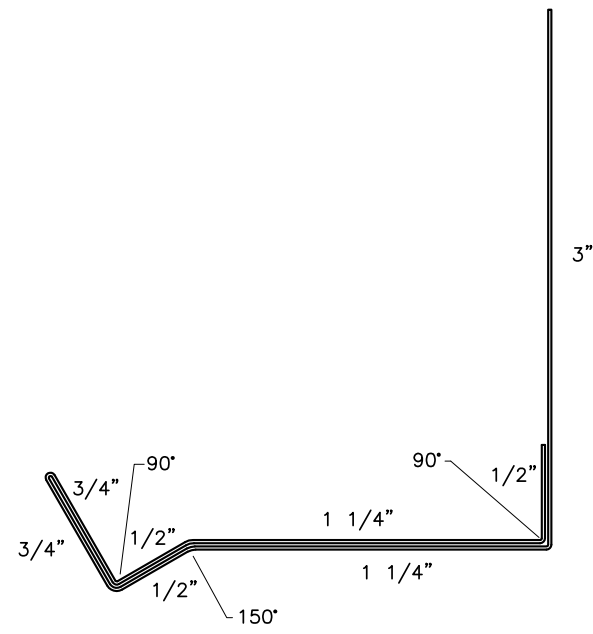

'COLOUR SIDE'

GIRTH: 8 1/2"

GAUGE	WEIGHT
29	0.40#/FT.
28	0.44#/FT.
26	0.53#/FT.
24	0.71#/FT.

exsteel BUILDING COMPONENTS		7825 Springwater Road Aylmer, Ontario N5H 2R4 519 - 765 - 2244 www.exsteel.com	
DATE:	MAR 28/2006	DRAWN:	SB
DATE:		CHECKED:	
DATE:		PROG:	
DATE:		ISSUED:	
DESCRIPTION: DRIP TRIM - HEADER - 5/8"-3/4" PANEL - C.B.S.			
DRAWING #		M151	
1	GENERAL DETAIL REVIEW	JAN 01/09	BJD
REV	DESCRIPTION	DATE	BY

'COLOUR SIDE'

M233
GIRTH: 4 1/2"

M279
GIRTH: 4 3/4"

M280
GIRTH: 5 1/2"

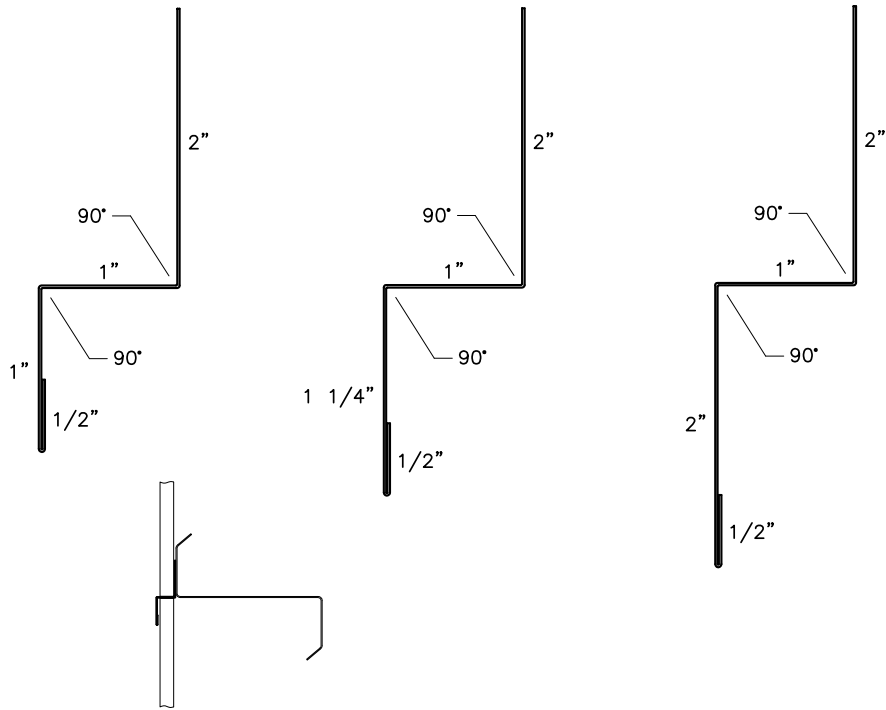

GAUGE	WEIGHT
29	0.26#/FT.
28	0.25#/FT.
26	0.30#/FT.
24	0.40#/FT.

		7825 Springwater Road Aylmer, Ontario N5H 2R4 519 - 765 - 2244 www.exsteel.com	
		DATE: JAN 27/2010	DRAWN: AF
DATE:		CHECKED:	
DATE:		PROG:	
DATE:		ISSUED:	
DESCRIPTION: PANEL TRANSITION TRIMS - 5/8"-3/4" PANEL			
DRAWING #		M233, M279 & M280	

REV	DESCRIPTION	DATE	BY
2	M279 & M280 ADDED	MAR 14/11	AF
1	GENERAL DETAIL REVIEW	JAN 27/10	LD

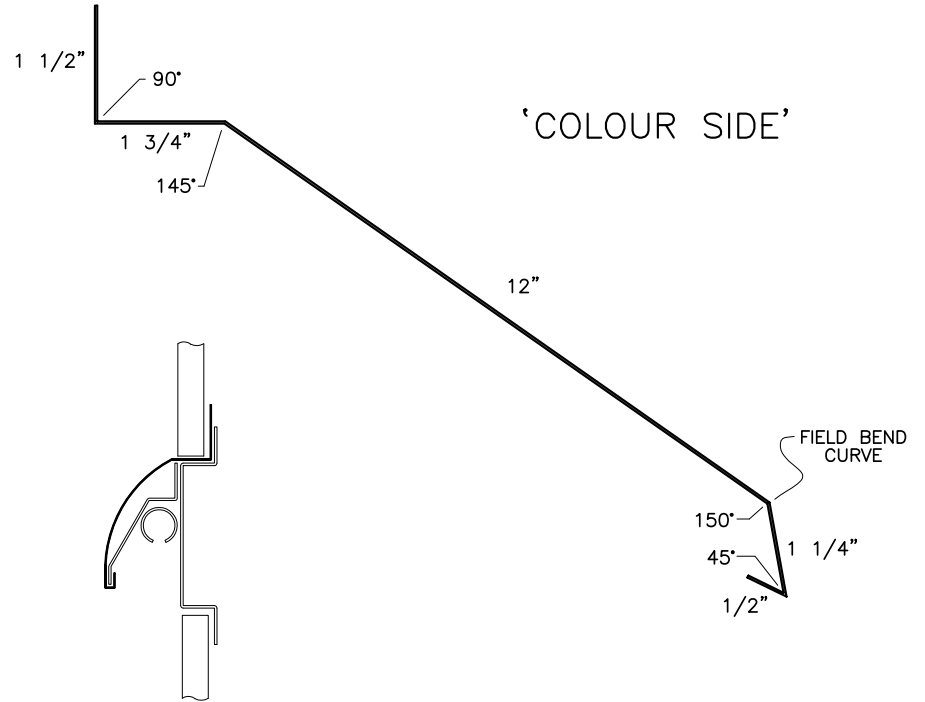

GIRTH: 17"

GAUGE	WEIGHT
29	0.80#/FT.
28	0.89#/FT.
26	1.06#/FT.
24	1.42#/FT.

		7825 Springwater Road Aylmer, Ontario N5H 2R4 519 - 765 - 2244 www.exsteel.com	
		DATE: NOV 27/2000	DRAWN: IMO
DATE:		CHECKED:	
DATE:		PROG:	
DATE:		ISSUED:	
DESCRIPTION: TRACK COVER			
DRAWING #		M114	

REV	DESCRIPTION	DATE	BY
1	GENERAL DETAIL REVIEW	JAN 01/09	BJD

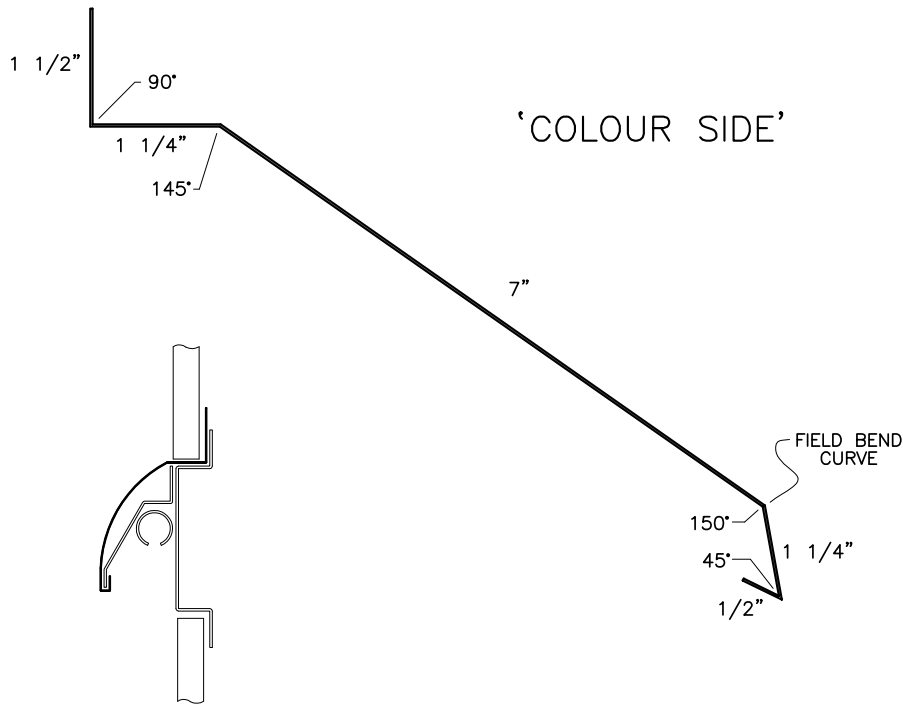

GIRTH: 11 1/2"

GAUGE	WEIGHT
29	0.53#/FT.
28	0.58#/FT.
26	0.70#/FT.
24	0.94#/FT.

		7825 Springwater Road Aylmer, Ontario N5H 2R4 519 - 765 - 2244 www.exsteel.com	
		DATE: MAR 22/2010	DRAWN: AF
DATE:		CHECKED:	
DATE:		PROG:	
DATE:		ISSUED:	
DESCRIPTION:			
TRACK COVER - 5/8"-3/4" PANEL			
DRAWING #		M240	
1	GENERAL DETAIL REVIEW	MAR 22/10	LD
REV	DESCRIPTION	DATE	BY

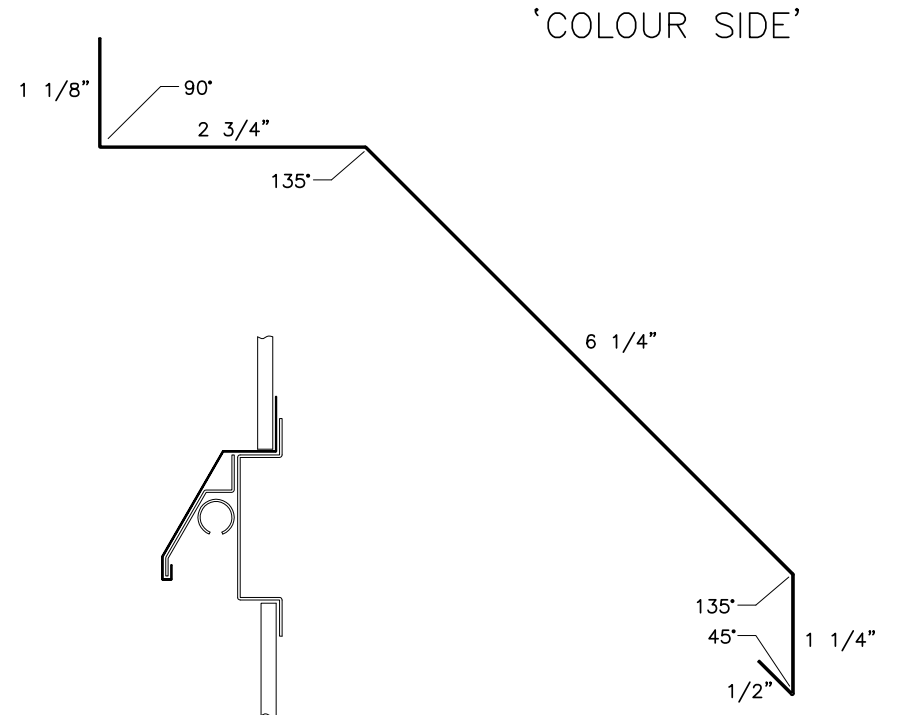

GIRTH: 11 7/8"

GAUGE	WEIGHT
29	0.65#/FT.
28	0.62#/FT.
26	0.75#/FT.
24	0.99#/FT.

		7825 Springwater Road Aylmer, Ontario N5H 2R4 519 - 765 - 2244 www.exsteel.com	
		DATE: MAR 14/2011	DRAWN: AF
DATE:		CHECKED:	
DATE:		PROG:	
DATE:		ISSUED:	
DESCRIPTION:			
TRACK COVER - 5/8"-3/4" PANEL			
DRAWING #		M281	
1	GENERAL DETAIL REVIEW	MAR 14/11	AF
REV	DESCRIPTION	DATE	BY

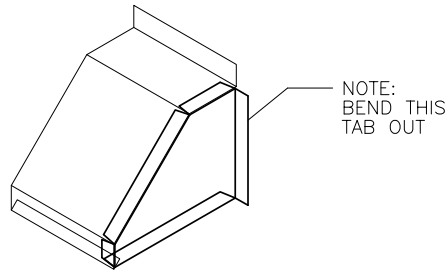
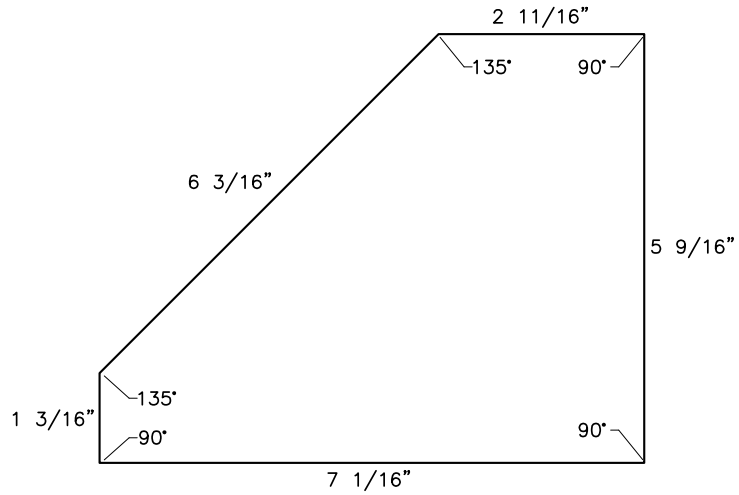

GAUGE	WEIGHT
29	0.17#ea.
28	0.16#ea.
26	0.20#ea.
24	0.27#ea.

exsteel BUILDING COMPONENTS		7825 Springwater Road Aylmer, Ontario N5H 2R4 519 - 765 - 2244 www.exsteel.com	
DATE: JAN 19/2011	DRAWN: AF		
DATE:	CHECKED:		
DATE:	PROG:		
DATE:	ISSUED:		
DESCRIPTION: END CAP - TRACK COVER (M281) - RIGHT			
DRAWING #			M272
1	GENERAL DETAIL REVIEW	MAR 14/11	AF
REV	DESCRIPTION	DATE	BY

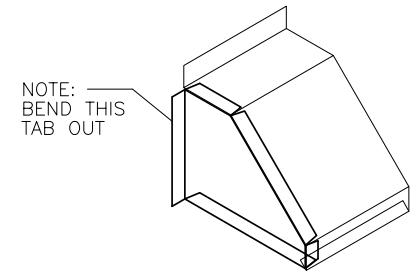
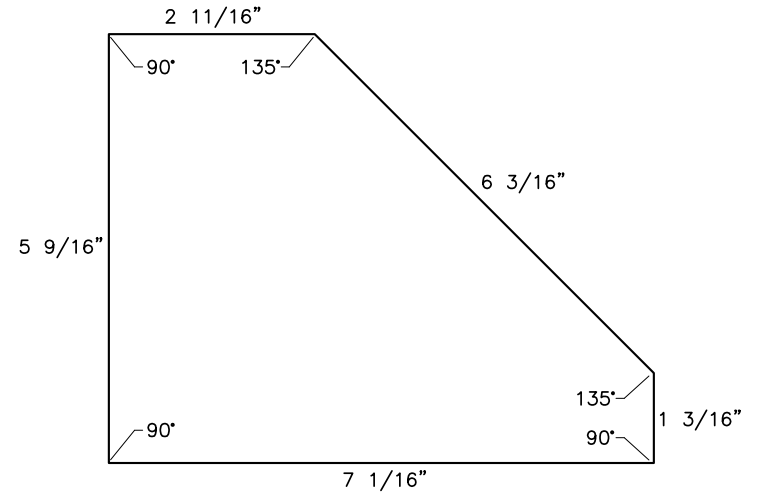

GAUGE	WEIGHT
29	0.17#ea.
28	0.16#ea.
26	0.20#ea.
24	0.27#ea.

exsteel BUILDING COMPONENTS		7825 Springwater Road Aylmer, Ontario N5H 2R4 519 - 765 - 2244 www.exsteel.com	
DATE: JAN 19/2011	DRAWN: AF		
DATE:	CHECKED:		
DATE:	PROG:		
DATE:	ISSUED:		
DESCRIPTION: END CAP - TRACK COVER (M281) - LEFT			
DRAWING #			M271
1	GENERAL DETAIL REVIEW	MAR 14/11	AF
REV	DESCRIPTION	DATE	BY

'COLOUR SIDE'

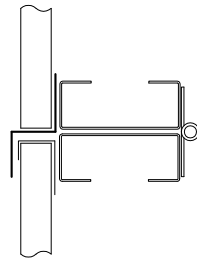
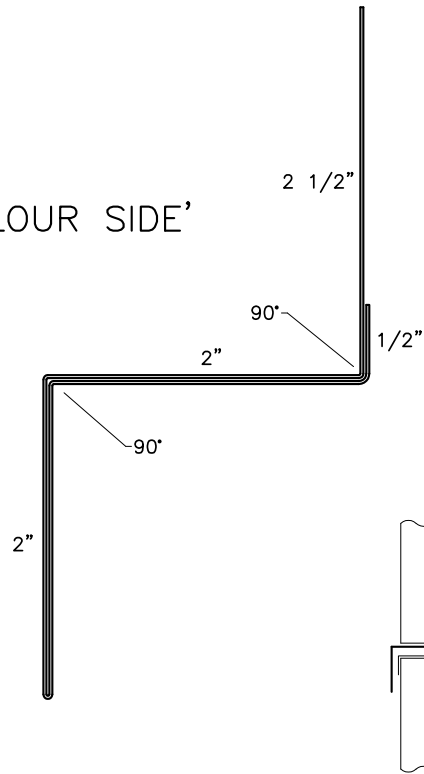

GIRTH: 11"

GAUGE	WEIGHT
29	0.60#/FT.
28	0.58#/FT.
26	0.69#/FT.
24	0.92#/FT.

		7825 Springwater Road Aylmer, Ontario N5H 2R4 519 - 765 - 2244 www.exsteel.com	
		DATE: DEC 18/2009	DRAWN: MM
DATE:		CHECKED:	
DATE:		PROG:	
DATE:		ISSUED:	
DESCRIPTION: 'Z' FLASHING FOR BI-FOLD DOOR - 1 1/2" PANEL - C.B.S.			
DRAWING #		M227	

REV	DESCRIPTION	DATE	BY
2	EXTRA MATERIAL ADDED	JAN 11/11	LD
1	GENERAL DETAIL REVIEW	JAN 01/09	BJD

'COLOUR SIDE'

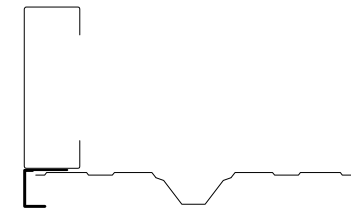
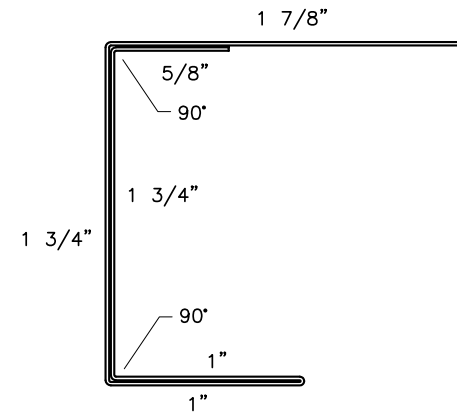

GIRTH: 8"

GAUGE	WEIGHT
29	0.38#/FT.
28	0.42#/FT.
26	0.50#/FT.
24	0.67#/FT.

		7825 Springwater Road Aylmer, Ontario N5H 2R4 519 - 765 - 2244 www.exsteel.com	
		DATE: JAN 23/1990	DRAWN: BVERN
DATE:		CHECKED:	
DATE:		PROG:	
DATE:		ISSUED:	
DESCRIPTION: 'J' TRIM - 1 1/2" PANEL - C.B.S.			
DRAWING #		M05	

REV	DESCRIPTION	DATE	BY
1	GENERAL DETAIL REVIEW	JAN 01/09	BJD

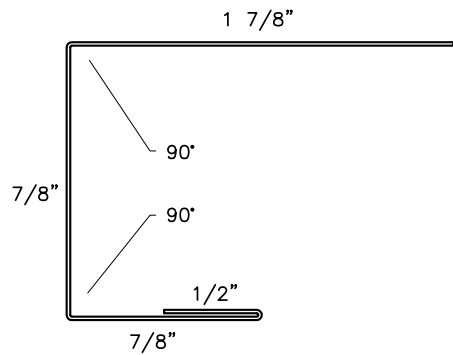

'COLOUR SIDE'

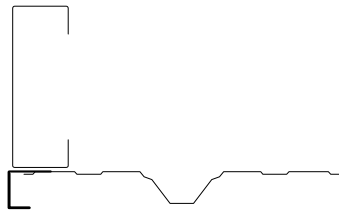

GIRTH: 4 1/8"

GAUGE	WEIGHT
29	0.23#/FT.
28	0.22#/FT.
26	0.26#/FT.
24	0.35#/FT.

exsteel BUILDING COMPONENTS		7825 Springwater Road Aylmer, Ontario N5H 2R4 519 - 765 - 2244 www.exsteel.com	
DATE:	DEC 03/2009	DRAWN:	AF
DATE:		CHECKED:	
DATE:		PROG:	
DATE:		ISSUED:	
DESCRIPTION: 'J' TRIM - 5/8"-3/4" PANEL - C.O.S.			
DRAWING #		M225	
REV	DESCRIPTION	DATE	BY
2	DIMENSIONS AND GIRTH REVISED	DEC 02/10	LD
1	GENERAL DETAIL REVIEW	JAN 01/09	BJD

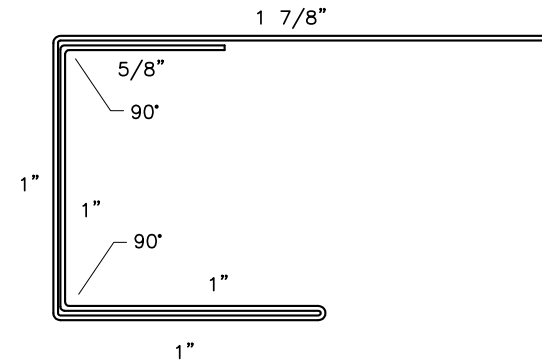

'COLOUR SIDE'

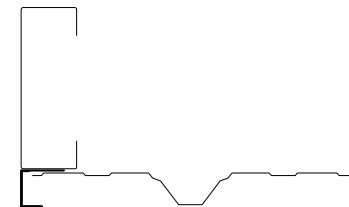

GIRTH: 6 1/2"

GAUGE	WEIGHT
29	0.31#/FT.
28	0.34#/FT.
26	0.41#/FT.
24	0.54#/FT.

exsteel BUILDING COMPONENTS		7825 Springwater Road Aylmer, Ontario N5H 2R4 519 - 765 - 2244 www.exsteel.com	
DATE:	MAR 28/2006	DRAWN:	SB
DATE:		CHECKED:	
DATE:		PROG:	
DATE:		ISSUED:	
DESCRIPTION: 'J' TRIM - 5/8"-3/4" PANEL - C.B.S.			
DRAWING #		M142	
REV	DESCRIPTION	DATE	BY
1	GENERAL DETAIL REVIEW	JAN 01/09	BJD

'COLOUR SIDE'

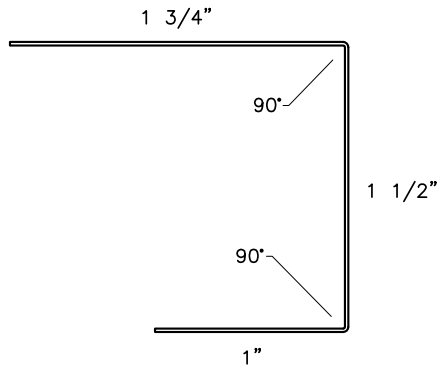

GIRTH: 4 1/4"

GAUGE	WEIGHT
29	0.22#/FT.
28	0.25#/FT.
26	0.29#/FT.
24	0.37#/FT.

exsteel BUILDING COMPONENTS		7825 Springwater Road Aylmer, Ontario N5H 2R4 519 - 765 - 2244 www.exsteel.com	
DATE:	JAN 24/1990	DRAWN:	BVERN
DATE:		CHECKED:	
DATE:		PROG:	
DATE:		ISSUED:	
DESCRIPTION: 'J' PACKER - 1 1/2" - C.O.S.			
DRAWING #		M07	
1	GENERAL DETAIL REVIEW	JAN 01/09	BJD
REV	DESCRIPTION	DATE	BY

'COLOUR SIDE'

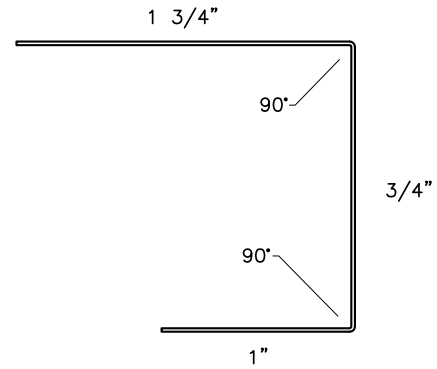

GIRTH: 3 1/2"

GAUGE	WEIGHT
29	0.16#/FT.
28	0.21#/FT.
26	0.24#/FT.
24	0.31#/FT.

exsteel BUILDING COMPONENTS		7825 Springwater Road Aylmer, Ontario N5H 2R4 519 - 765 - 2244 www.exsteel.com	
DATE:	MAR 28/2006	DRAWN:	SB
DATE:		CHECKED:	
DATE:		PROG:	
DATE:		ISSUED:	
DESCRIPTION: 'J' PACKER - 3/4" - C.O.S.			
DRAWING #		M143	
1	GENERAL DETAIL REVIEW	JAN 01/09	BJD
REV	DESCRIPTION	DATE	BY

'COLOUR SIDE'

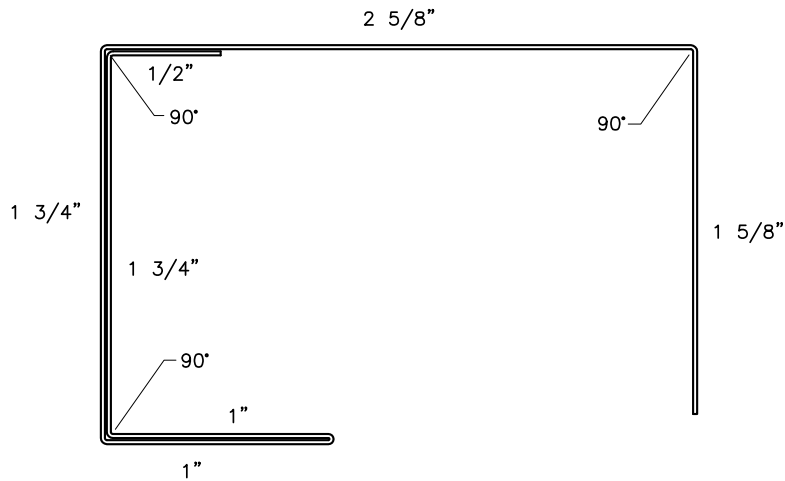

GIRTH: 10 1/4"

GAUGE	WEIGHT
29	0.65#/FT.
28	0.53#/FT.
26	0.64#/FT.
24	0.85#/FT.

exsteel BUILDING COMPONENTS		7825 Springwater Road Aylmer, Ontario N5H 2R4 519 - 765 - 2244 www.exsteel.com	
DATE:	AUG 7/1998	DRAWN:	BVERN
DATE:		CHECKED:	
DATE:		PROG:	
DATE:		ISSUED:	
DESCRIPTION: JAMB TRIM - 1 1/2" PANEL			
DRAWING #		M103	
1	GENERAL DETAIL REVIEW	JAN 01/09	BJD
REV	DESCRIPTION	DATE	BY

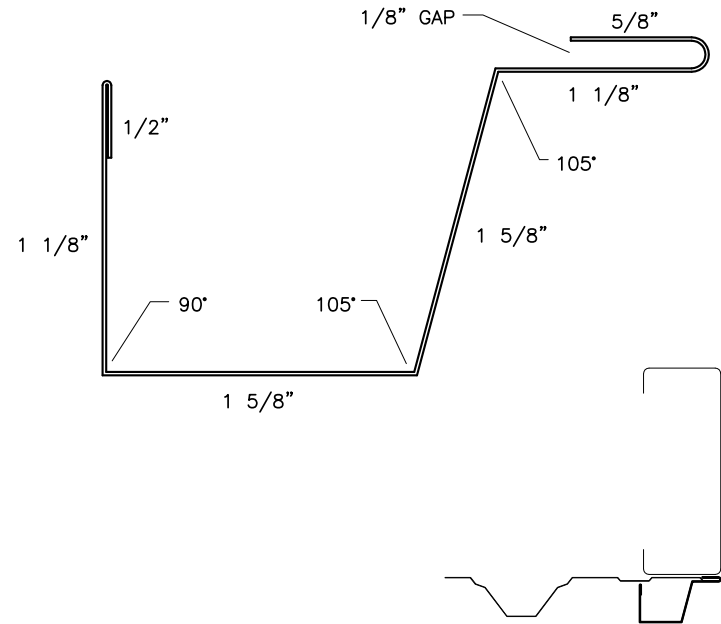

GIRTH: 6 5/8"

GAUGE	WEIGHT
29	0.35#/FT.
28	0.35#/FT.
26	0.41#/FT.
24	0.55#/FT.

exsteel BUILDING COMPONENTS		7825 Springwater Road Aylmer, Ontario N5H 2R4 519 - 765 - 2244 www.exsteel.com	
DATE:	MAR 19/2001	DRAWN:	MAG
DATE:		CHECKED:	
DATE:		PROG:	
DATE:		ISSUED:	
DESCRIPTION: JAMB TRIM - 1 1/2" PANEL			
DRAWING #		M113	
1	GENERAL DETAIL REVIEW	JAN 01/09	BJD
REV	DESCRIPTION	DATE	BY

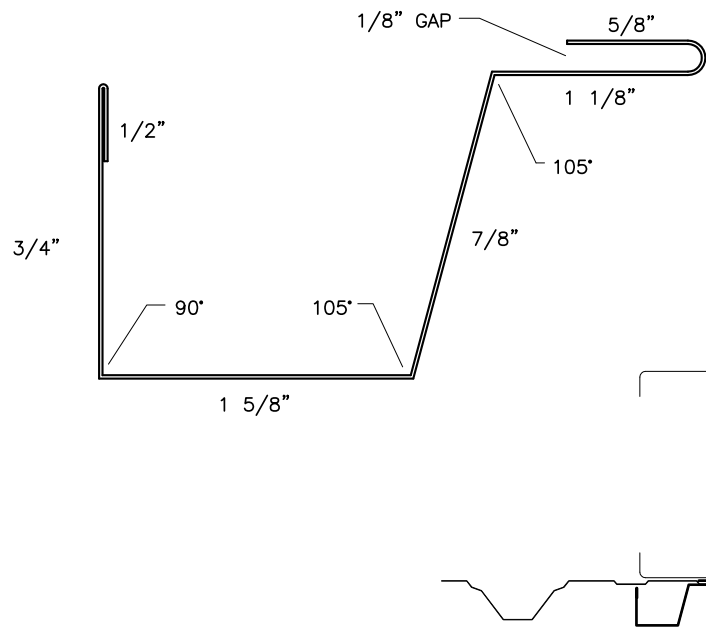

GIRTH: 5 1/2"

GAUGE	WEIGHT
29	0.26#/FT.
28	0.29#/FT.
26	0.34#/FT.
24	0.46#/FT.

exsteel BUILDING COMPONENTS	7825 Springwater Road Aylmer, Ontario N5H 2R4 519 - 765 - 2244 www.exsteel.com	
	DATE: MAR 28/2006	DRAWN: SB
	DATE:	CHECKED:
	DATE:	PROG:
	DATE:	ISSUED:

DESCRIPTION:
JAMB TRIM - 5/8"-3/4" PANEL

REV	DESCRIPTION	DATE	BY
1	GENERAL DETAIL REVIEW	JAN 01/09	BJD

DRAWING # M152

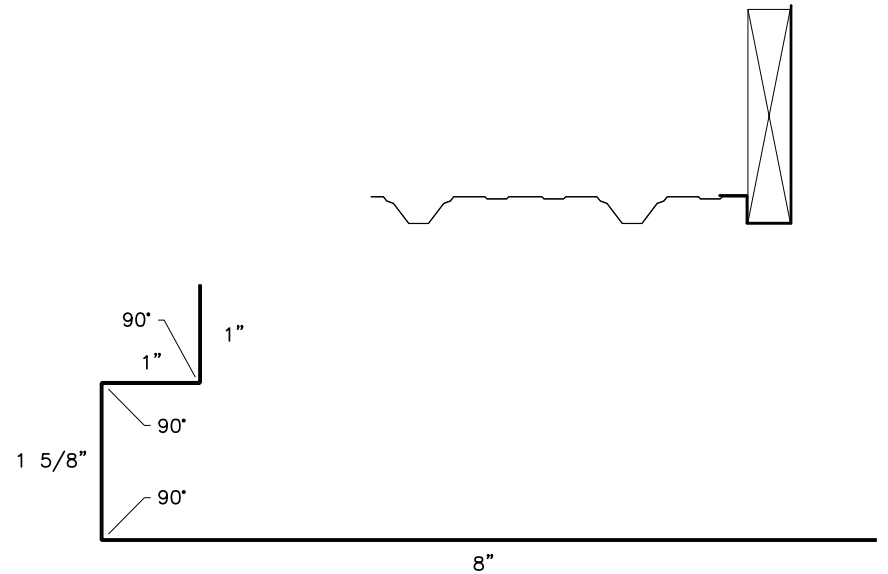

'COLOUR SIDE'

GIRTH: 11 5/8"

GAUGE	WEIGHT
29	0.53#/FT.
28	0.59#/FT.
26	0.71#/FT.
24	0.95#/FT.

exsteel BUILDING COMPONENTS	7825 Springwater Road Aylmer, Ontario N5H 2R4 519 - 765 - 2244 www.exsteel.com	
	DATE: MAR 22/2010	DRAWN: AF
	DATE:	CHECKED:
	DATE:	PROG:
	DATE:	ISSUED:

DESCRIPTION:
8" JAMB TRIM - 5/8"-3/4" PANEL

REV	DESCRIPTION	DATE	BY
2	DESCRIPTION UPDATED	FEB 04/11	AF
1	GENERAL DETAIL REVIEW	MAR 22/10	LD

DRAWING # M241

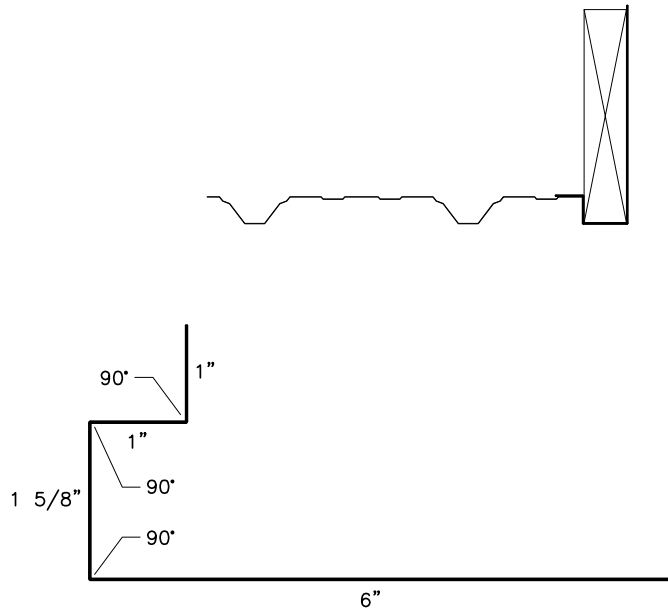

'COLOUR SIDE'

GIRTH: 9 5/8"

GAUGE	WEIGHT
29	0.53#/FT.
28	0.51#/FT.
26	0.61#/FT.
24	0.81#/FT.

exsteel BUILDING COMPONENTS		7825 Springwater Road Aylmer, Ontario N5H 2R4 519 - 765 - 2244 www.exsteel.com	
DATE: JAN 12/2011	DRAWN: AF		
DATE:	CHECKED:		
DATE:	PROG:		
DATE:	ISSUED:		

DESCRIPTION:
6" JAMB TRIM - 5/8"-3/4" PANEL

REV	DESCRIPTION	DATE	BY
1	GENERAL DETAIL REVIEW	MAR 14/11	AF

DRAWING #
M251

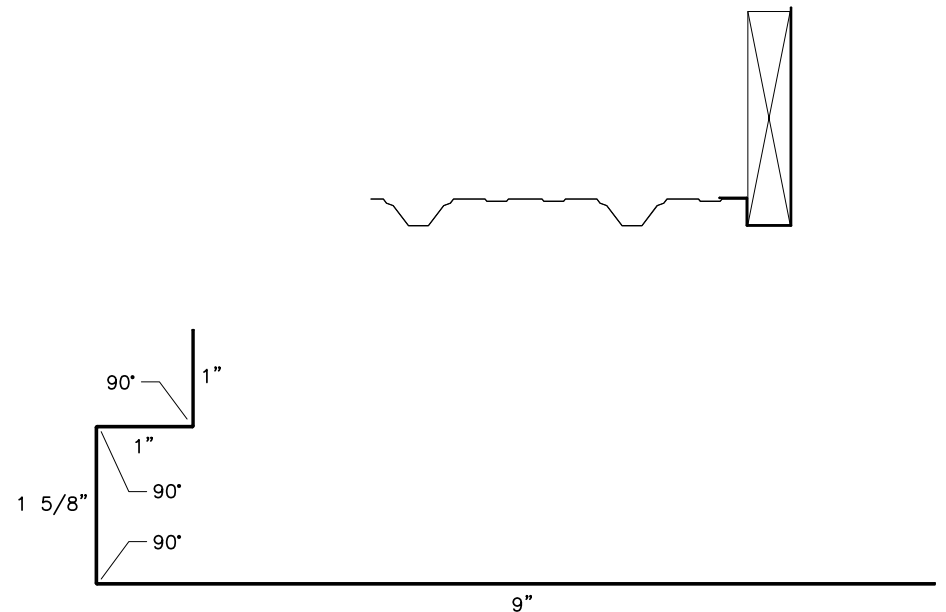

'COLOUR SIDE'

GIRTH: 12 5/8"

GAUGE	WEIGHT
29	0.69#/FT.
28	0.66#/FT.
26	0.79#/FT.
24	1.06#/FT.

exsteel BUILDING COMPONENTS		7825 Springwater Road Aylmer, Ontario N5H 2R4 519 - 765 - 2244 www.exsteel.com	
DATE: JAN 12/2011	DRAWN: AF		
DATE:	CHECKED:		
DATE:	PROG:		
DATE:	ISSUED:		

DESCRIPTION:
9" JAMB TRIM - 5/8"-3/4" PANEL

REV	DESCRIPTION	DATE	BY
1	GENERAL DETAIL REVIEW	MAR 14/11	AF

DRAWING #
M252

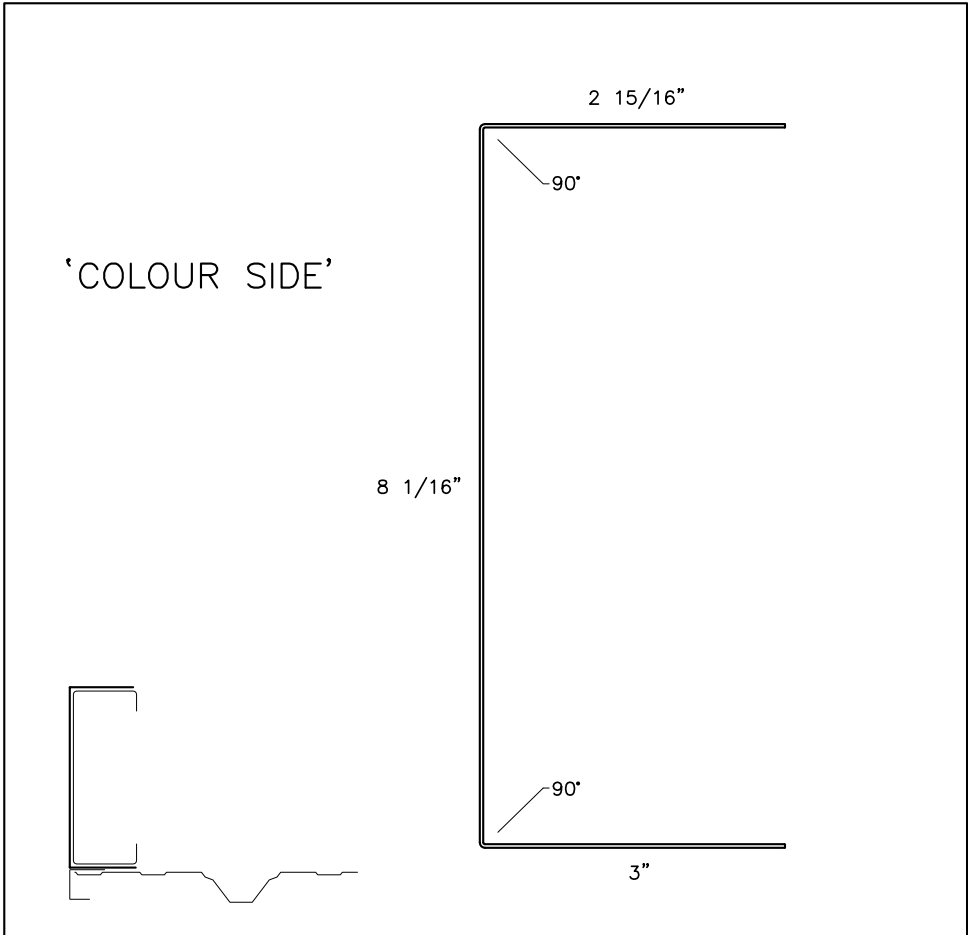

GIRTH: 14"

GAUGE	WEIGHT
29	0.66#/FT.
28	0.73#/FT.
26	0.88#/FT.
24	1.17#/FT.

exsteel BUILDING COMPONENTS		7825 Springwater Road Aylmer, Ontario N5H 2R4 519 - 765 - 2244 www.exsteel.com	
DATE:	AUG 24/2000	DRAWN:	IMO
DATE:		CHECKED:	
DATE:		PROG:	
DATE:		ISSUED:	
DESCRIPTION:			

JAMB WRAP TRIM (8" CEE)

REV	DESCRIPTION	DATE	BY
1	GENERAL DETAIL REVIEW	JAN 01/09	BJD

DRAWING # M108

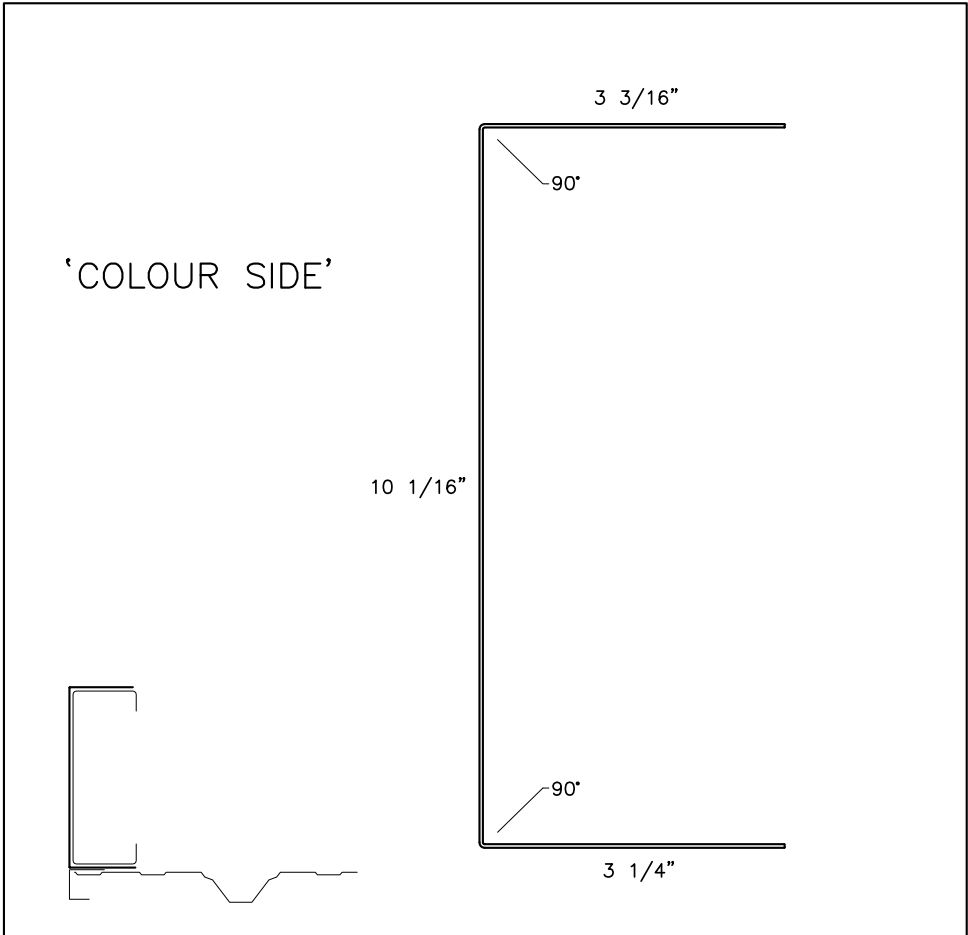

GIRTH: 16 1/2"

GAUGE	WEIGHT
29	0.77#/FT.
28	0.86#/FT.
26	1.03#/FT.
24	1.38#/FT.

exsteel BUILDING COMPONENTS		7825 Springwater Road Aylmer, Ontario N5H 2R4 519 - 765 - 2244 www.exsteel.com	
DATE:	AUG 24/2000	DRAWN:	IMO
DATE:		CHECKED:	
DATE:		PROG:	
DATE:		ISSUED:	
DESCRIPTION:			

JAMB WRAP TRIM (10" CEE)

REV	DESCRIPTION	DATE	BY
1	GENERAL DETAIL REVIEW	JAN 01/09	BJD

DRAWING # M109

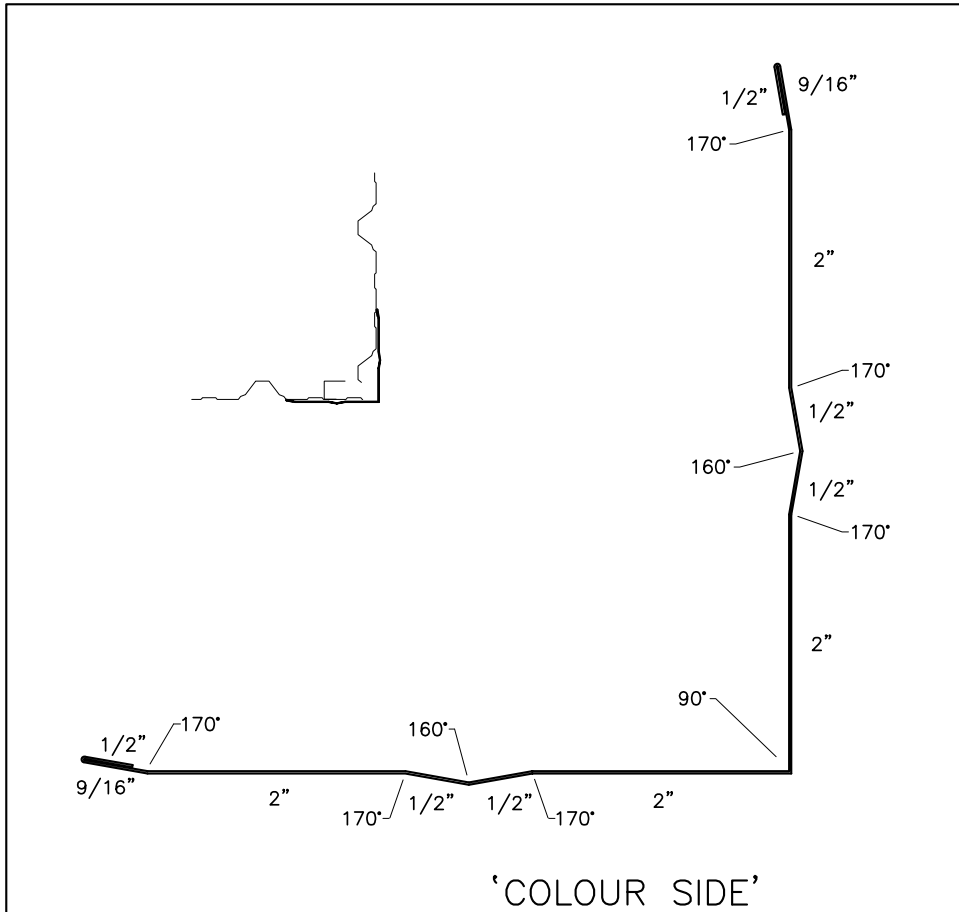

'COLOUR SIDE'

GIRTH: 12 1/8"

GAUGE	WEIGHT
29	0.50#/FT.
28	0.69#/FT.
26	0.80#/FT.
24	1.03#/FT.

 BUILDING COMPONENTS	7825 Springwater Road Aylmer, Ontario N5H 2R4 519 - 765 - 2244 www.exsteel.com	
	DATE: JAN 24/1990	DRAWN: BVERN
	DATE:	CHECKED:
	DATE:	PROG:
	DATE:	ISSUED:
DESCRIPTION: CORNER TRIM - OUTSIDE - 1 1/2" PANEL		
DRAWING #		M06

REV	DESCRIPTION	DATE	BY
1	GENERAL DETAIL REVIEW	JAN 01/09	BJD

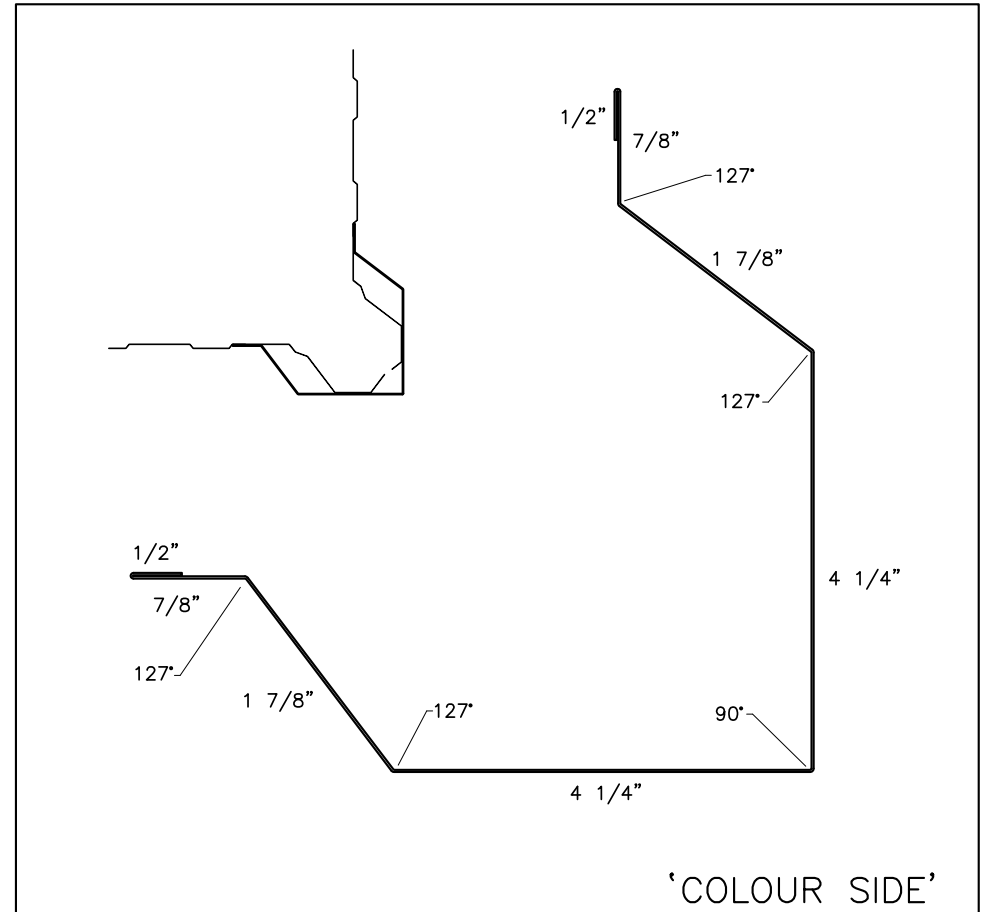

'COLOUR SIDE'

GIRTH: 15"

GAUGE	WEIGHT
29	0.75#/FT.
28	0.78#/FT.
26	0.94#/FT.
24	1.25#/FT.

 BUILDING COMPONENTS	7825 Springwater Road Aylmer, Ontario N5H 2R4 519 - 765 - 2244 www.exsteel.com	
	DATE: MAR 19/2001	DRAWN: MAG
	DATE:	CHECKED:
	DATE:	PROG:
	DATE:	ISSUED:
DESCRIPTION: CORNER TRIM (WITH PROFILE) - OUTSIDE - 1 1/2" PANEL		
DRAWING #		M128

REV	DESCRIPTION	DATE	BY
1	GENERAL DETAIL REVIEW	JAN 01/09	BJD

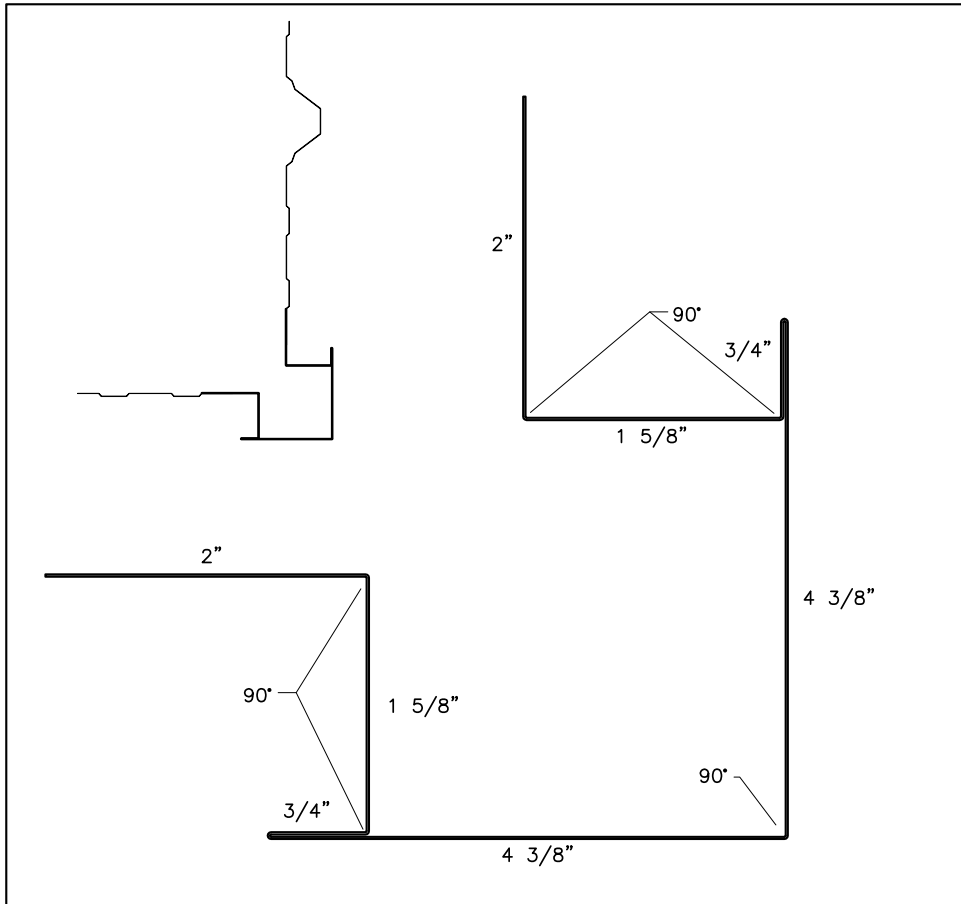

GIRTH: 17 1/2"

'COLOUR SIDE'

GAUGE	WEIGHT
29	0.82#/FT.
28	0.91#/FT.
26	1.09#/FT.
24	1.46#/FT.

exsteel BUILDING COMPONENTS		7825 Springwater Road Aylmer, Ontario N5H 2R4 519 - 765 - 2244 www.exsteel.com	
DATE:	MAR 31/2006	DRAWN:	IMO
DATE:		CHECKED:	
DATE:		PROG:	
DATE:		ISSUED:	

DESCRIPTION: CORNER TRIM - OUTSIDE
- 1 1/2" PANEL

REV	DESCRIPTION	DATE	BY
1	GENERAL DETAIL REVIEW	JAN 01/09	BJD

DRAWING # M140

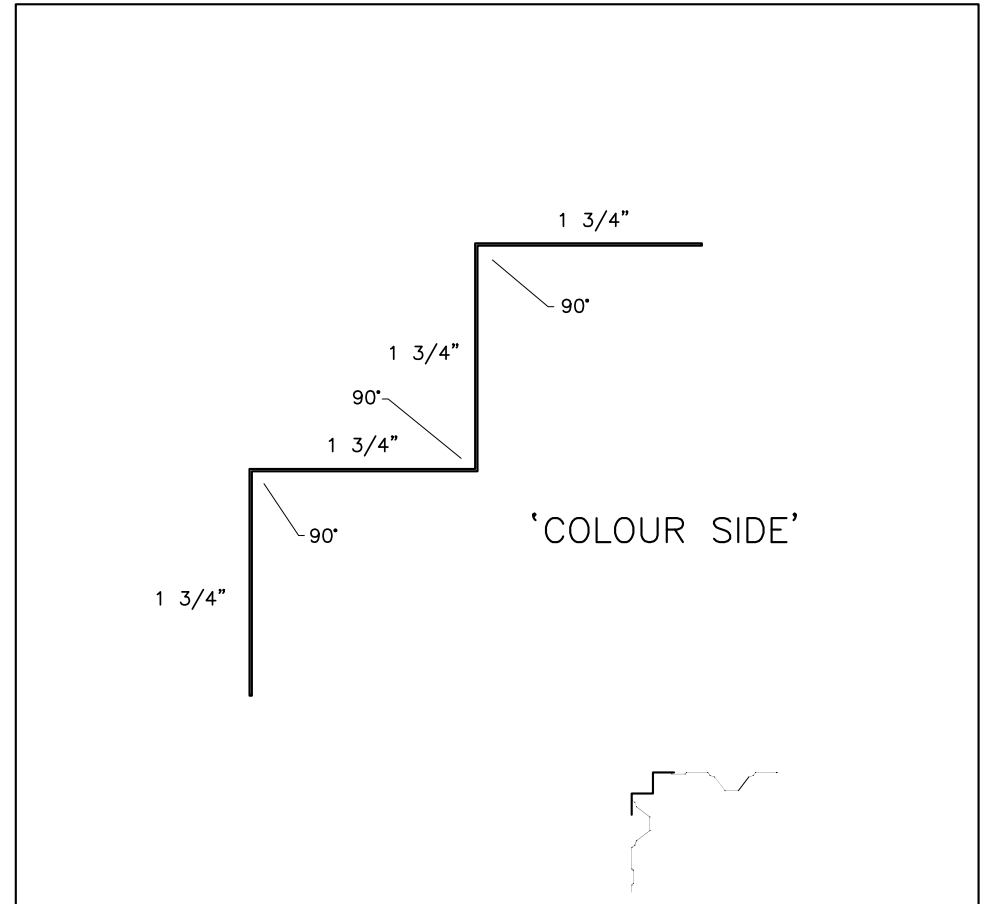

GIRTH: 7"

'COLOUR SIDE'

GAUGE	WEIGHT
29	0.36#/FT.
28	0.41#/FT.
26	0.48#/FT.
24	0.61#/FT.

exsteel BUILDING COMPONENTS		7825 Springwater Road Aylmer, Ontario N5H 2R4 519 - 765 - 2244 www.exsteel.com	
DATE:	JAN 24/1990	DRAWN:	BVERN
DATE:		CHECKED:	
DATE:		PROG:	
DATE:		ISSUED:	

DESCRIPTION: CORNER TRIM - INSIDE -
UP TO 1 1/2" PANEL

REV	DESCRIPTION	DATE	BY
1	GENERAL DETAIL REVIEW	JAN 01/09	BJD

DRAWING # M10

PITCH	DESIG.	A°
0/12	P00	90°
.25/12	P02	91°
.5/12	P05	92.5°
1/12	P10	94.75°
2/12	P20	99.5°
3/12	P30	104°
4/12	P40	108.5°

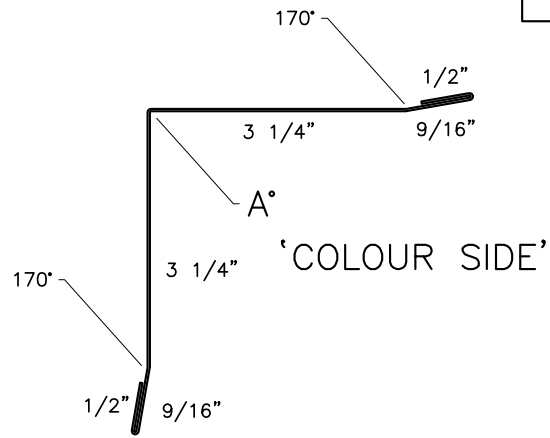

GIRTH: 8 5/8"

GAUGE	WEIGHT
29	0.41#/FT.
28	0.45#/FT.
26	0.54#/FT.
24	0.72#/FT.

exsteel BUILDING COMPONENTS	7825 Springwater Road Aylmer, Ontario N5H 2R4 519 - 765 - 2244 www.exsteel.com	
	DATE: APR 5/2004	DRAWN: IMO
	DATE:	CHECKED:
	DATE:	PROG:
DATE:	ISSUED:	
DESCRIPTION: CORNER TRIM - INSIDE - 1 1/2" PANEL		
DRAWING #	M138	

REV	DESCRIPTION	DATE	BY
1	GENERAL DETAIL REVIEW	JAN 01/09	BJD

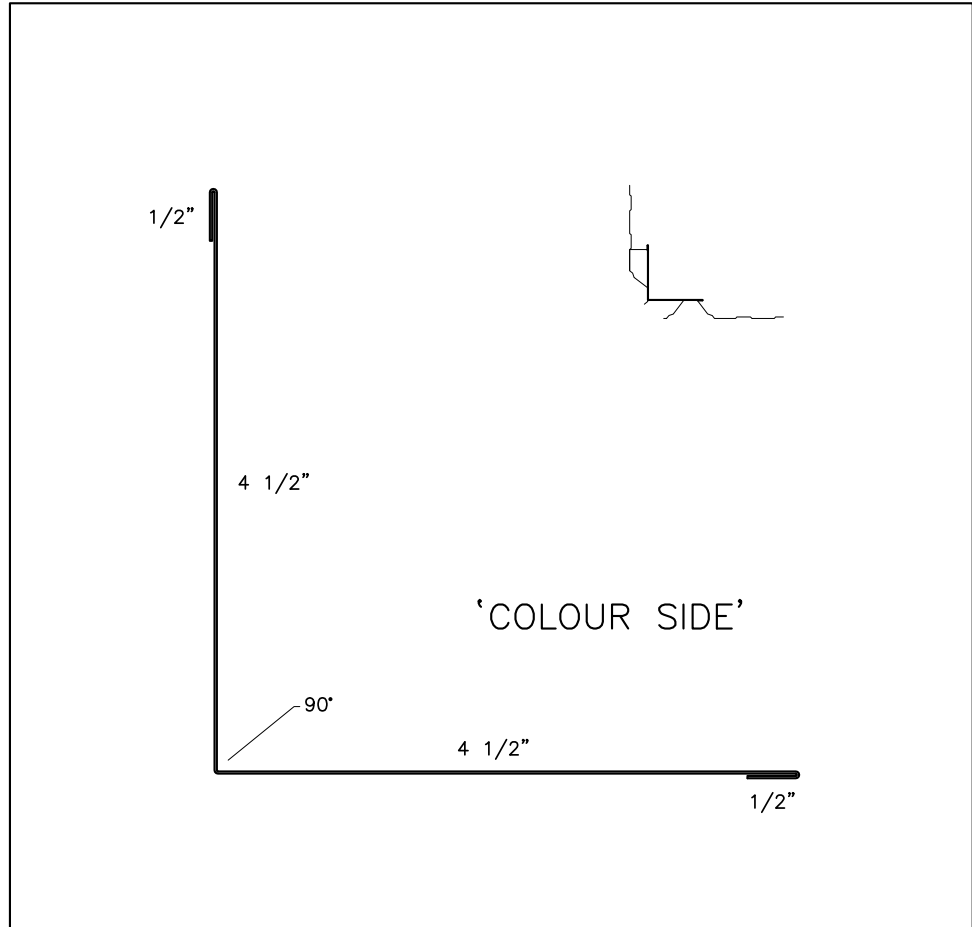

GIRTH: 10"

GAUGE	WEIGHT
29	0.47#/FT.
28	0.57#/FT.
26	0.66#/FT.
24	0.86#/FT.

exsteel BUILDING COMPONENTS	7825 Springwater Road Aylmer, Ontario N5H 2R4 519 - 765 - 2244 www.exsteel.com	
	DATE: JAN 24/1990	DRAWN: BVERN
	DATE:	CHECKED:
	DATE:	PROG:
DATE:	ISSUED:	
DESCRIPTION: CORNER TRIM - INSIDE - 1 1/2" PANEL		
DRAWING #	M15	

REV	DESCRIPTION	DATE	BY
1	GENERAL DETAIL REVIEW	JAN 01/09	BJD

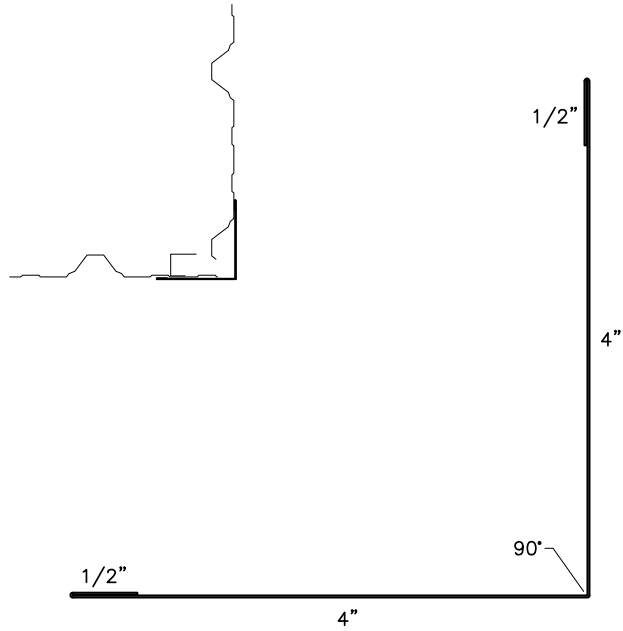

'COLOUR SIDE'

GIRTH: 9"

GAUGE	WEIGHT
29	0.49#/FT.
28	0.47#/FT.
26	0.57#/FT.
24	0.75#/FT.

exsteel BUILDING COMPONENTS		7825 Springwater Road Aylmer, Ontario N5H 2R4 519 - 765 - 2244 www.exsteel.com	
DATE: JAN 19/2011	DRAWN: AF		
DATE:	CHECKED:		
DATE:	PROG:		
DATE:	ISSUED:		
DESCRIPTION: CORNER TRIM - OUTSIDE - 5/8"-3/4" PANEL			
DRAWING #		M273	

REV	DESCRIPTION	DATE	BY
1	GENERAL DETAIL REVIEW	MAR 14/11	AF

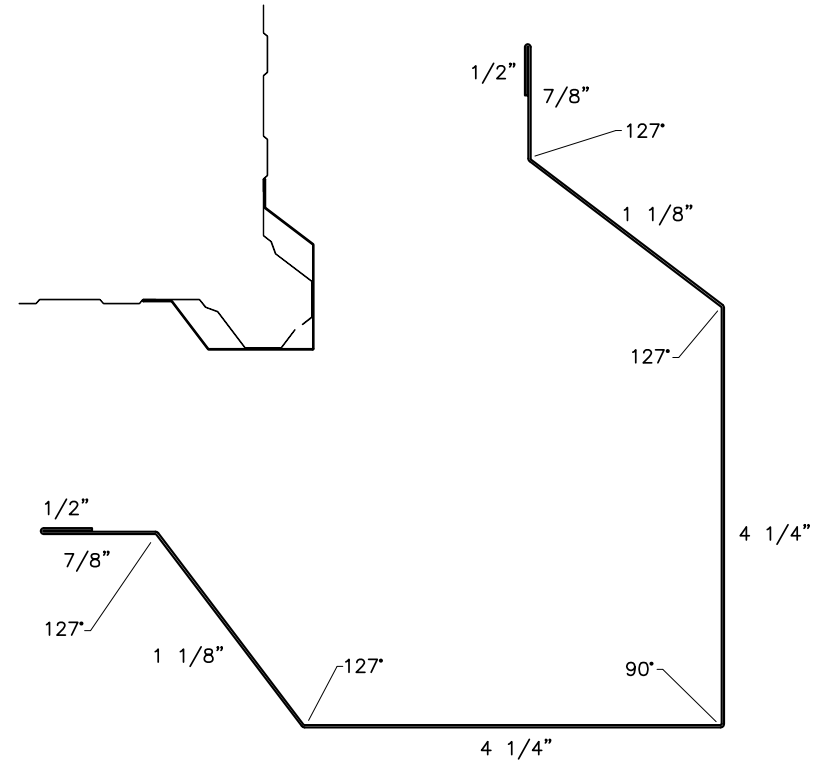

'COLOUR SIDE'

GIRTH: 13 1/2"

GAUGE	WEIGHT
29	0.64#/FT.
28	0.70#/FT.
26	0.85#/FT.
24	1.13#/FT.

exsteel BUILDING COMPONENTS		7825 Springwater Road Aylmer, Ontario N5H 2R4 519 - 765 - 2244 www.exsteel.com	
DATE: MAR 28/2006	DRAWN: SB		
DATE:	CHECKED:		
DATE:	PROG:		
DATE:	ISSUED:		
DESCRIPTION: CORNER TRIM (WITH PROFILE) - OUTSIDE - 5/8"-3/4" PANEL			
DRAWING #		M156	

REV	DESCRIPTION	DATE	BY
1	GENERAL DETAIL REVIEW	JAN 01/09	BJD

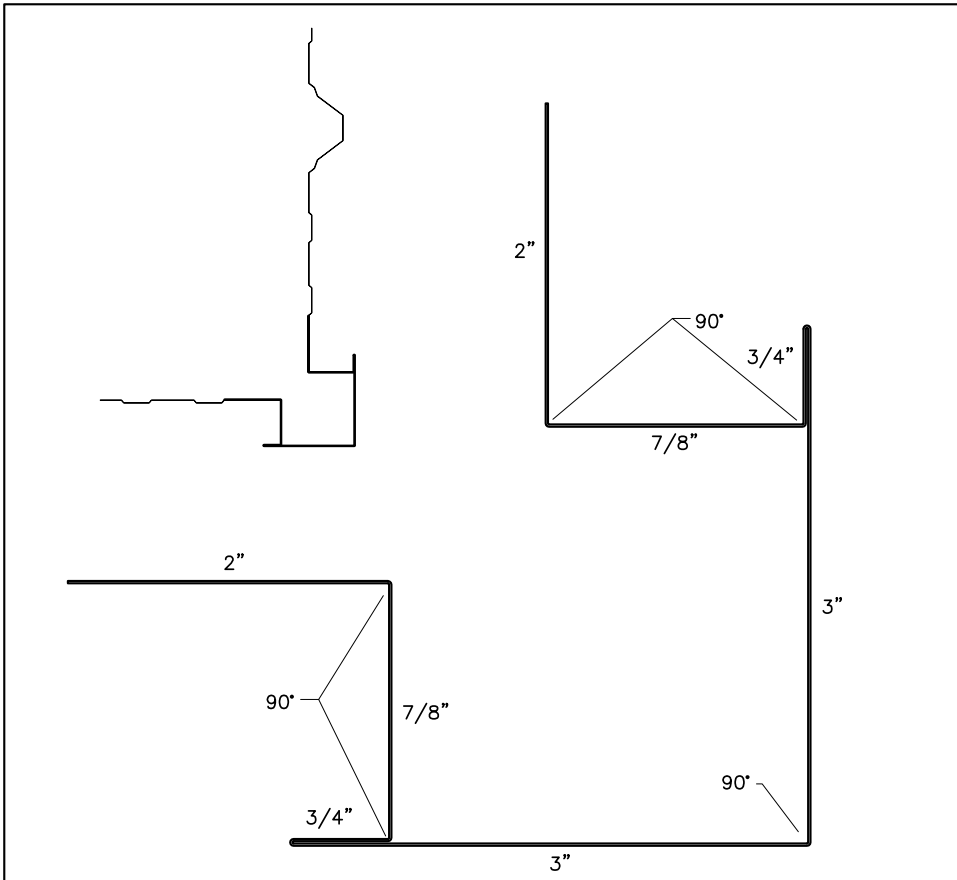

GIRTH: 13 1/4"

'COLOUR SIDE'

GAUGE	WEIGHT
29	0.62#/FT.
28	0.77#/FT.
26	0.90#/FT.
24	1.17#/FT.

	7825 Springwater Road Aylmer, Ontario N5H 2R4 519 - 765 - 2244 www.exsteel.com
	BUILDING COMPONENTS
DATE: MAR 28/2006	DRAWN: SB
DATE:	CHECKED:
DATE:	PROG:
DATE:	ISSUED:

DESCRIPTION: CORNER TRIM - OUTSIDE
- UP TO 3/4" PANEL

1	GENERAL DETAIL REVIEW	JAN 01/09	BJD
REV	DESCRIPTION	DATE	BY

DRAWING # M146

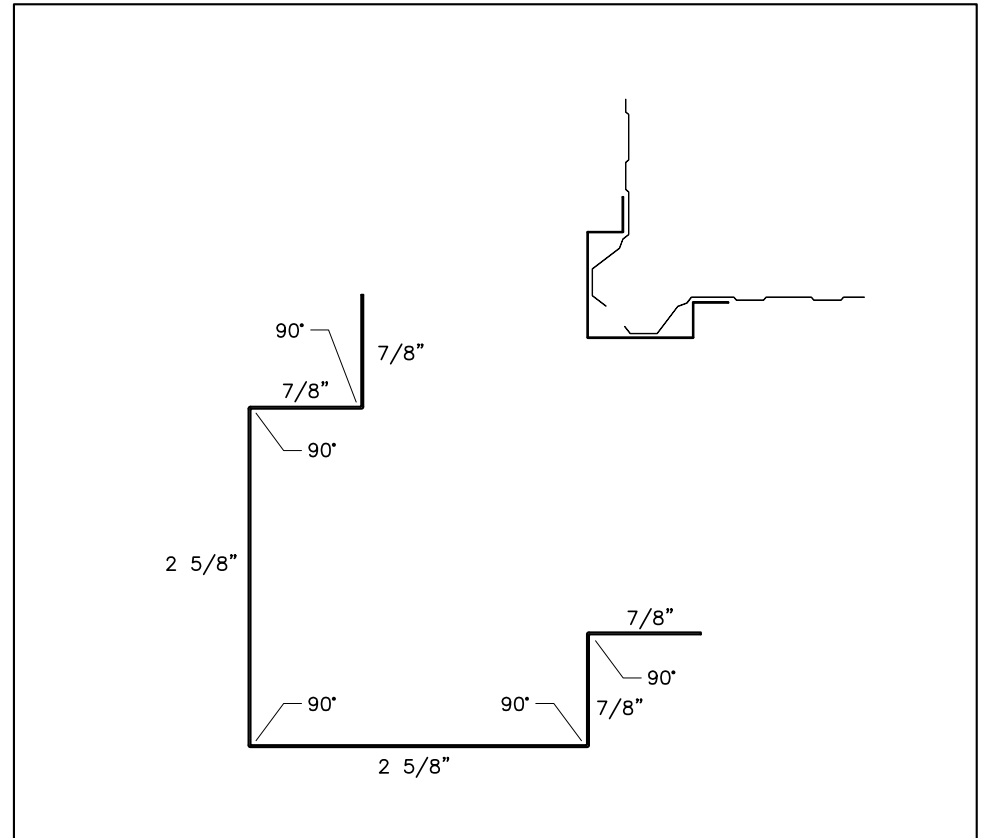

'COLOUR SIDE'

GIRTH: 8 3/4"

GAUGE	WEIGHT
29	0.48#/FT.
28	0.46#/FT.
26	0.55#/FT.
24	0.73#/FT.

	7825 Springwater Road Aylmer, Ontario N5H 2R4 519 - 765 - 2244 www.exsteel.com
	BUILDING COMPONENTS
DATE: JAN 12/2011	DRAWN: AF
DATE:	CHECKED:
DATE:	PROG:
DATE:	ISSUED:

DESCRIPTION: CORNER TRIM - OUTSIDE -
5/8"-3/4" PANEL

1	GENERAL DETAIL REVIEW	MAR 14/11	AF
REV	DESCRIPTION	DATE	BY

DRAWING # M254

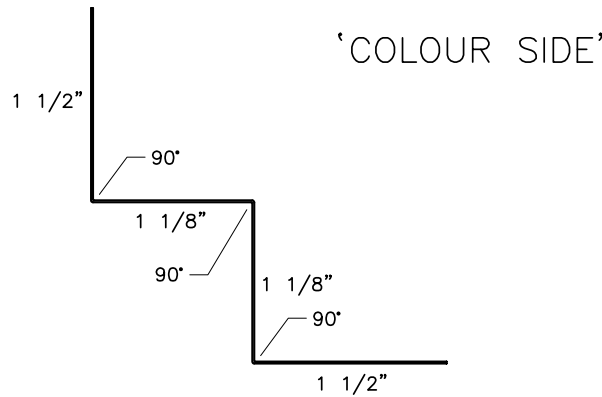
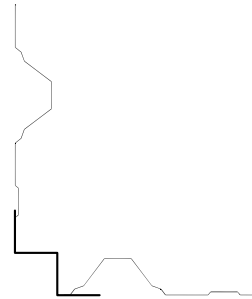

GIRTH: 5 1/4"

GAUGE	WEIGHT
29	0.29#/FT.
28	0.28#/FT.
26	0.33#/FT.
24	0.44#/FT.

exsteel BUILDING COMPONENTS		7825 Springwater Road Aylmer, Ontario N5H 2R4 519 - 765 - 2244 www.exsteel.com	
DATE: JAN 12/2011	DRAWN: AF		
DATE:	CHECKED:		
DATE:	PROG:		
DATE:	ISSUED:		
DESCRIPTION: CORNER TRIM - INSIDE - 5/8"-3/4" PANEL			
DRAWING #			M253
1	GENERAL DETAIL REVIEW	MAR 14/11	AF
REV	DESCRIPTION	DATE	BY

1	GENERAL DETAIL REVIEW	MAR 14/11	AF
REV	DESCRIPTION	DATE	BY

PITCH	DESIG.	A°
0/12	P00	90°
.25/12	P02	91°
.5/12	P05	92.5°
1/12	P10	94.75°
2/12	P20	99.5°
3/12	P30	104°
4/12	P40	108.5°

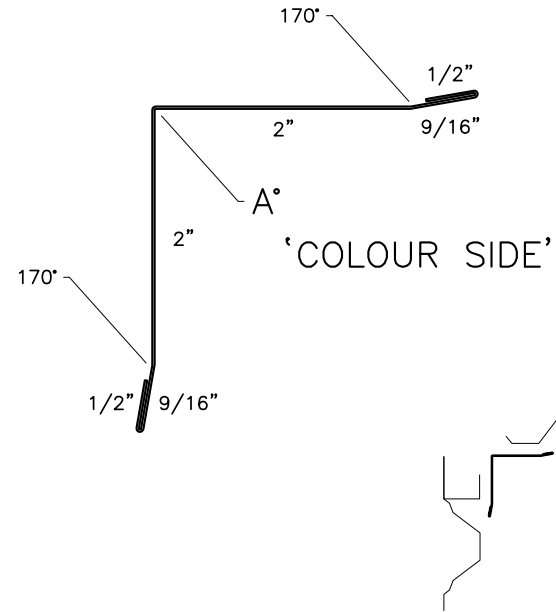

GIRTH: 6 1/8"

GAUGE	WEIGHT
29	0.24#/FT.
28	0.34#/FT.
26	0.39#/FT.
24	0.51#/FT.

exsteel BUILDING COMPONENTS		7825 Springwater Road Aylmer, Ontario N5H 2R4 519 - 765 - 2244 www.exsteel.com	
DATE: JAN 30/1990	DRAWN: BVERN		
DATE:	CHECKED:		
DATE:	PROG:		
DATE:	ISSUED:		
DESCRIPTION: CORNER TRIM - INSIDE - 5/8"-3/4" PANEL			
DRAWING #			M33
1	GENERAL DETAIL REVIEW	JAN 01/09	BJD
REV	DESCRIPTION	DATE	BY

1	GENERAL DETAIL REVIEW	JAN 01/09	BJD
REV	DESCRIPTION	DATE	BY

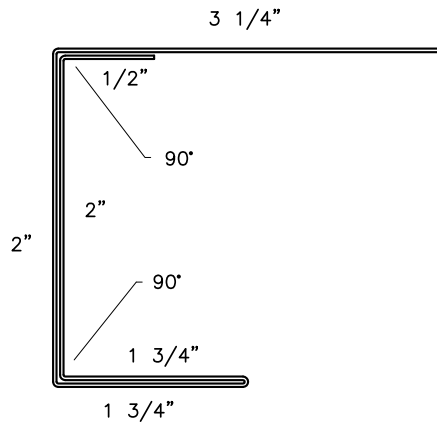

'COLOUR SIDE'

GIRTH: 11 1/4"

GAUGE	WEIGHT
29	0.53#/FT.
28	0.59#/FT.
26	0.70#/FT.
24	0.94#/FT.

		7825 Springwater Road Aylmer, Ontario N5H 2R4 519 - 765 - 2244 www.exsteel.com	
		DATE: APR 5/2004	DRAWN: SB
DATE:		CHECKED:	
DATE:		PROG:	
DATE:		ISSUED:	
DESCRIPTION: LINER CAP TRIM - 1 1/2" PANEL - C.B.S.			
DRAWING #		M133	
1	GENERAL DETAIL REVIEW	JAN 01/09	BJD
REV	DESCRIPTION	DATE	BY

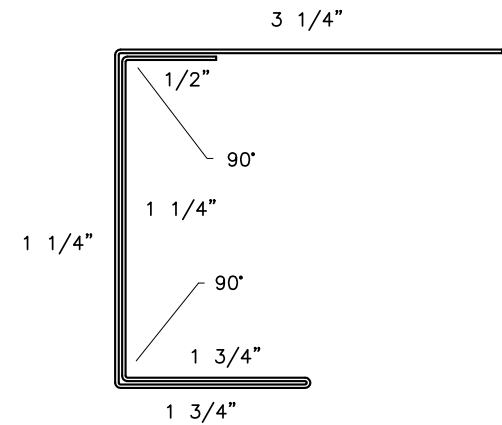

'COLOUR SIDE'

GIRTH: 9 3/4"

GAUGE	WEIGHT
29	0.46#/FT.
28	0.51#/FT.
26	0.61#/FT.
24	0.82#/FT.

		7825 Springwater Road Aylmer, Ontario N5H 2R4 519 - 765 - 2244 www.exsteel.com	
		DATE: MAR 28/2006	DRAWN: SB
DATE:		CHECKED:	
DATE:		PROG:	
DATE:		ISSUED:	
DESCRIPTION: LINER CAP TRIM - 5/8"-3/4" PANEL - C.B.S.			
DRAWING #		M158	
1	GENERAL DETAIL REVIEW	JAN 01/09	BJD
REV	DESCRIPTION	DATE	BY

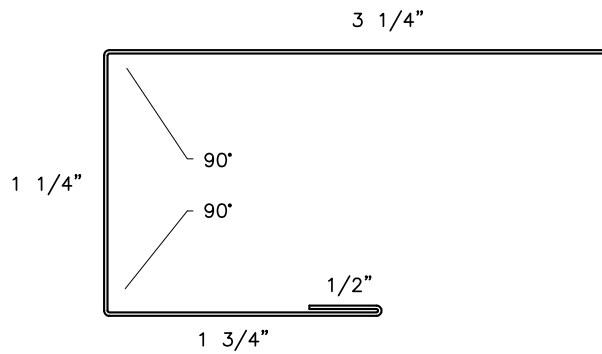

'COLOUR SIDE'

GIRTH: 6 3/4"

GAUGE	WEIGHT
29	0.31#/FT.
28	0.34#/FT.
26	0.41#/FT.
24	0.55#/FT.

		7825 Springwater Road Aylmer, Ontario N5H 2R4 519 - 765 - 2244 www.exsteel.com	
		DATE: DEC 03/2009	DRAWN: AF
DATE:		CHECKED:	
DATE:		PROG:	
DATE:		ISSUED:	
DESCRIPTION: LINER CAP TRIM - 5/8"-3/4" PANEL - C.O.S.			
DRAWING #		M226	

REV	DESCRIPTION	DATE	BY
1	GENERAL DETAIL REVIEW	DEC 03/09	LD

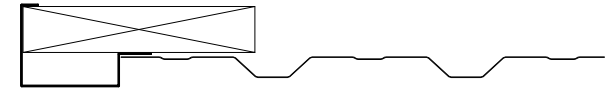

'COLOUR SIDE'

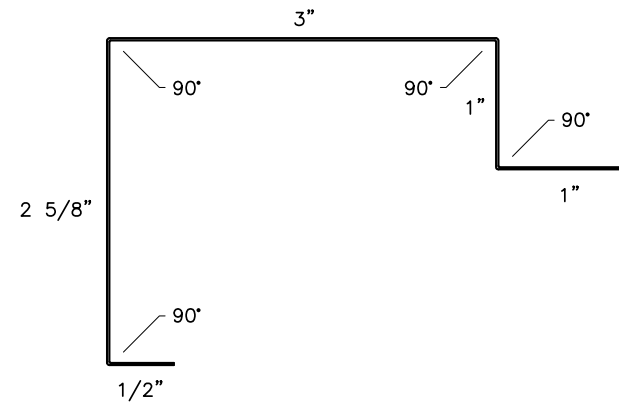

GIRTH: 8 1/8"

GAUGE	WEIGHT
29	0.37#/FT.
28	0.41#/FT.
26	0.49#/FT.
24	0.65#/FT.

		7825 Springwater Road Aylmer, Ontario N5H 2R4 519 - 765 - 2244 www.exsteel.com	
		DATE: MAR 22/2010	DRAWN: AF
DATE:		CHECKED:	
DATE:		PROG:	
DATE:		ISSUED:	
DESCRIPTION: SLIDING DOOR TRIM - 5/8"-3/4" PANEL			
DRAWING #		M242	

REV	DESCRIPTION	DATE	BY
2	REVISED DIMENSION	JUNE 19/11	AF
1	GENERAL DETAIL REVIEW	MAR 22/10	LD

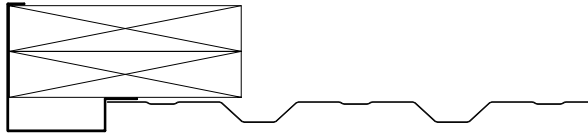

'COLOUR SIDE'

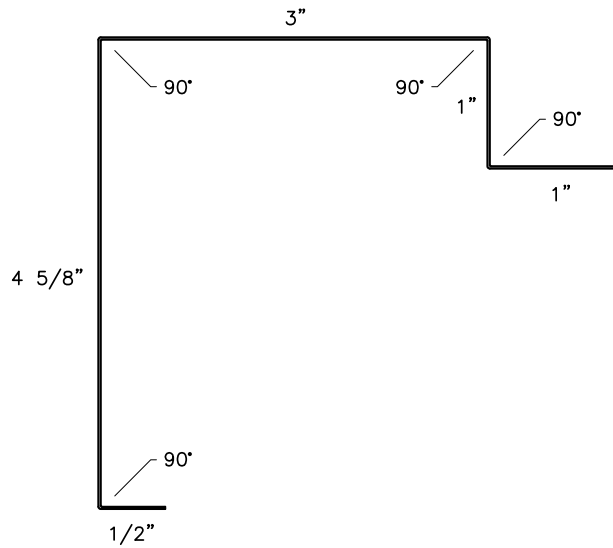

GIRTH: 10 1/8"

GAUGE	WEIGHT
29	0.55#/FT.
28	0.53#/FT.
26	0.64#/FT.
24	0.85#/FT.

exsteel BUILDING COMPONENTS		7825 Springwater Road Aylmer, Ontario N5H 2R4 519 - 765 - 2244 www.exsteel.com	
DATE:	JUNE 19/2011	DRAWN:	AF
DATE:		CHECKED:	
DATE:		PROG:	
DATE:		ISSUED:	
DESCRIPTION: SLIDING DOOR TRIM - 5/8"-3/4" PANEL			
DRAWING #		M260	

REV	DESCRIPTION	DATE	BY
1	GENERAL DETAIL REVIEW	JUN 19/11	AF

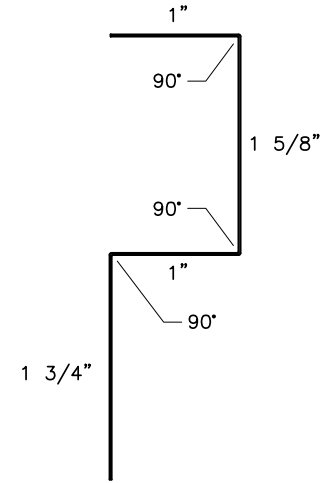
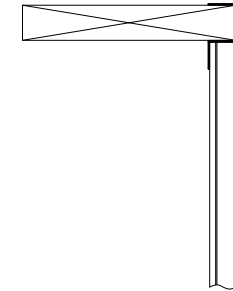

'COLOUR SIDE'

GIRTH: 5 3/8"

GAUGE	WEIGHT
29	0.30#/FT.
28	0.28#/FT.
26	0.34#/FT.
24	0.45#/FT.

exsteel BUILDING COMPONENTS		7825 Springwater Road Aylmer, Ontario N5H 2R4 519 - 765 - 2244 www.exsteel.com	
DATE:	JAN 12/2011	DRAWN:	AF
DATE:		CHECKED:	
DATE:		PROG:	
DATE:		ISSUED:	
DESCRIPTION: WINDOW TRIM - 5/8"-3/4" PANEL			
DRAWING #		M250	

REV	DESCRIPTION	DATE	BY
1	GENERAL DETAIL REVIEW	MAR 14/11	AF

'COLOUR SIDE'

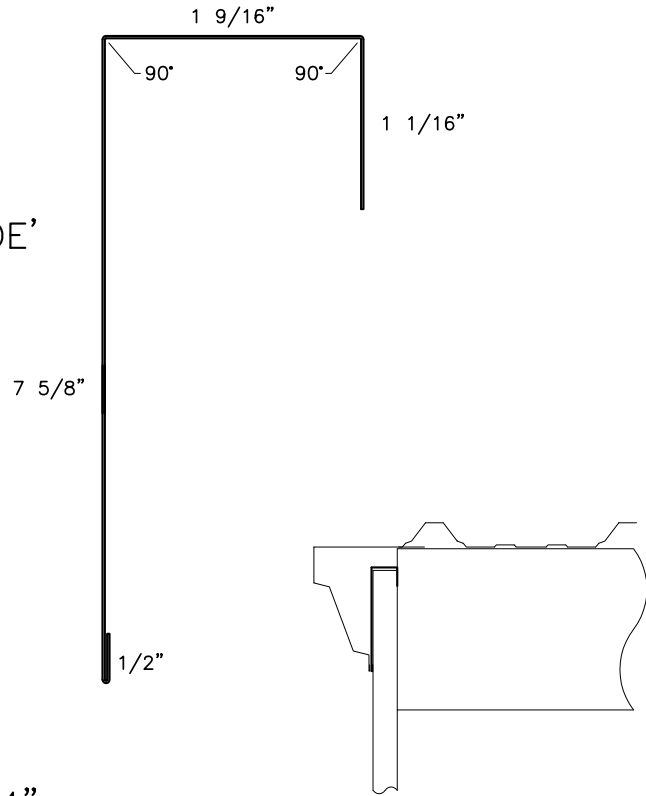

GIRTH: 10 3/4"

GAUGE	WEIGHT
29	0.50#/FT.
28	0.56#/FT.
26	0.67#/FT.
24	0.90#/FT.

exsteel BUILDING COMPONENTS		7825 Springwater Road Aylmer, Ontario N5H 2R4 519 - 765 - 2244 www.exsteel.com	
DATE: JAN 21/2000	DRAWN: IMO		
DATE:	CHECKED:		
DATE:	PROG:		
DATE:	ISSUED:		
DESCRIPTION: WALL CAP - GABLE (M03) - 1 1/2" WALL PANEL			
DRAWING #		M104	
1	GENERAL DETAIL REVIEW	JAN 01/09	BJD
REV	DESCRIPTION	DATE	BY

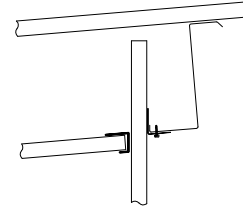

PITCH	DESIG.	A'	B'
.25/12	P02	89°	91°
.5/12	P05	87°	93°
1/12	P10	85°	95°
2/12	P20	81°	100°
3/12	P30	76°	104°
4/12	P40	72°	108°
5/12	P50	67°	113°
6/12	P60	64°	116°

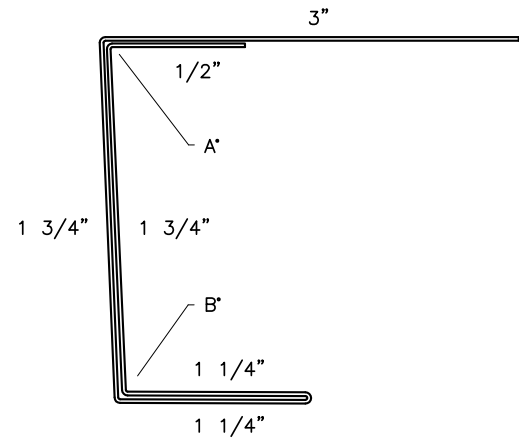

'COLOUR SIDE'

GIRTH: 9 1/2"

GAUGE	WEIGHT
29	0.44#/FT.
28	0.49#/FT.
26	0.59#/FT.
24	0.79#/FT.

exsteel BUILDING COMPONENTS		7825 Springwater Road Aylmer, Ontario N5H 2R4 519 - 765 - 2244 www.exsteel.com	
DATE: MAY 14/2009	DRAWN: LD		
DATE:	CHECKED:		
DATE:	PROG:		
DATE:	ISSUED:		
DESCRIPTION: OVERHANG SOFFIT TRIM - 1 1/2" PANEL			
DRAWING #		M232	
1	GENERAL DETAIL REVIEW	JAN 01/09	BJD
REV	DESCRIPTION	DATE	BY

PITCH	DESIG.	A°
.25/12	P02	103°
.5/12	P05	101.5°
1/12	P10	99°
2/12	P20	94.5°
3/12	P30	90°
4/12	P40	86°

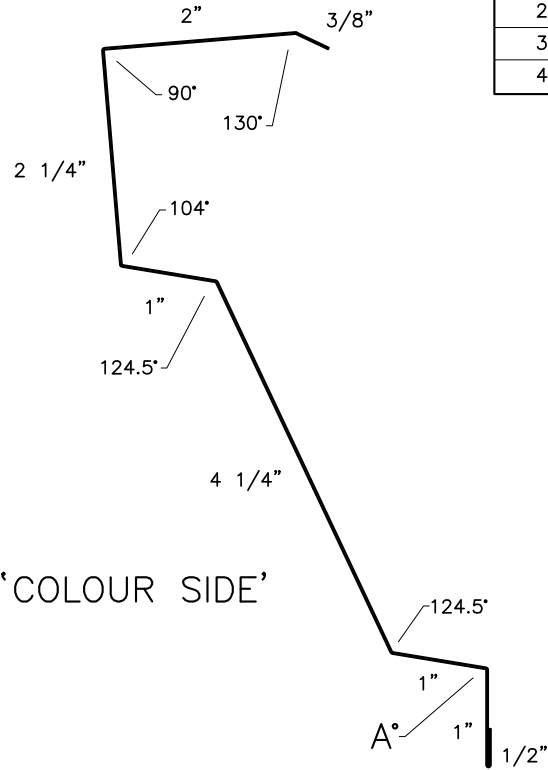

GIRTH: 12 3/8"

GAUGE	WEIGHT
29	0.62#/FT.
28	0.71#/FT.
26	0.83#/FT.
24	1.08#/FT.

exsteel BUILDING COMPONENTS	7825 Springwater Road Aylmer, Ontario N5H 2R4 519 - 765 - 2244 www.exsteel.com	
	DATE: JAN 23/1990	DRAWN: BVERN
	DATE:	CHECKED:
	DATE:	PROG:
DATE:	ISSUED:	
DESCRIPTION: LOW EAVE TRIM (WITH PROFILE) - SCREW DOWN/RTL-24 ROOF - UP TO 1 1/2" WALL PANEL		
DRAWING #	M02	

REV	DESCRIPTION	DATE	BY
1	GENERAL DETAIL REVIEW	JAN 01/09	BJD

PITCH	DESIG.	A°
.25/12	P02	103°
.5/12	P05	101.5°
1/12	P10	99°
2/12	P20	94.5°
3/12	P30	90°
4/12	P40	86°

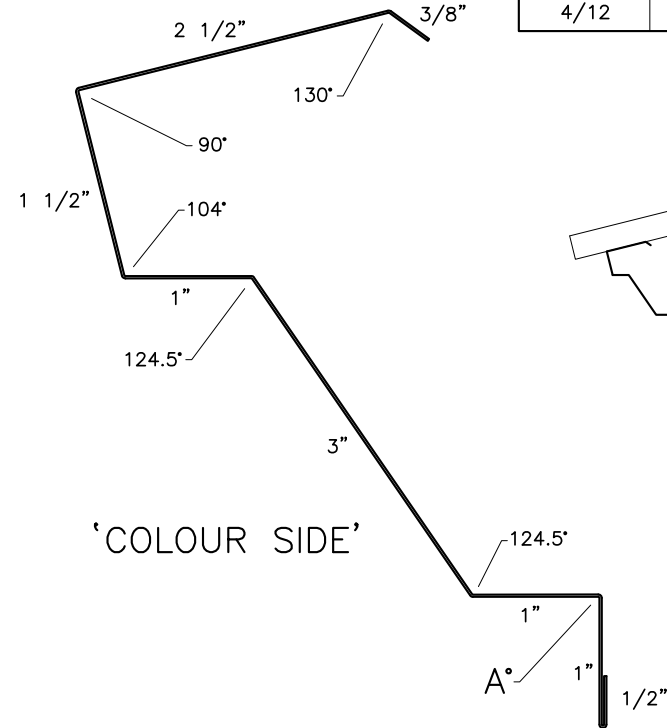

GIRTH: 10 7/8"

GAUGE	WEIGHT
29	0.50#/FT.
28	0.63#/FT.
26	0.73#/FT.
24	0.94#/FT.

exsteel BUILDING COMPONENTS	7825 Springwater Road Aylmer, Ontario N5H 2R4 519 - 765 - 2244 www.exsteel.com	
	DATE: JAN 30/1990	DRAWN: BVERN
	DATE:	CHECKED:
	DATE:	PROG:
DATE:	ISSUED:	
DESCRIPTION: LOW EAVE TRIM (WITH PROFILE) - SCREW DOWN/RTL-24 ROOF - 5/8"-3/4" WALL PANEL		
DRAWING #	M41	

REV	DESCRIPTION	DATE	BY
1	GENERAL DETAIL REVIEW	JAN 01/09	BJD

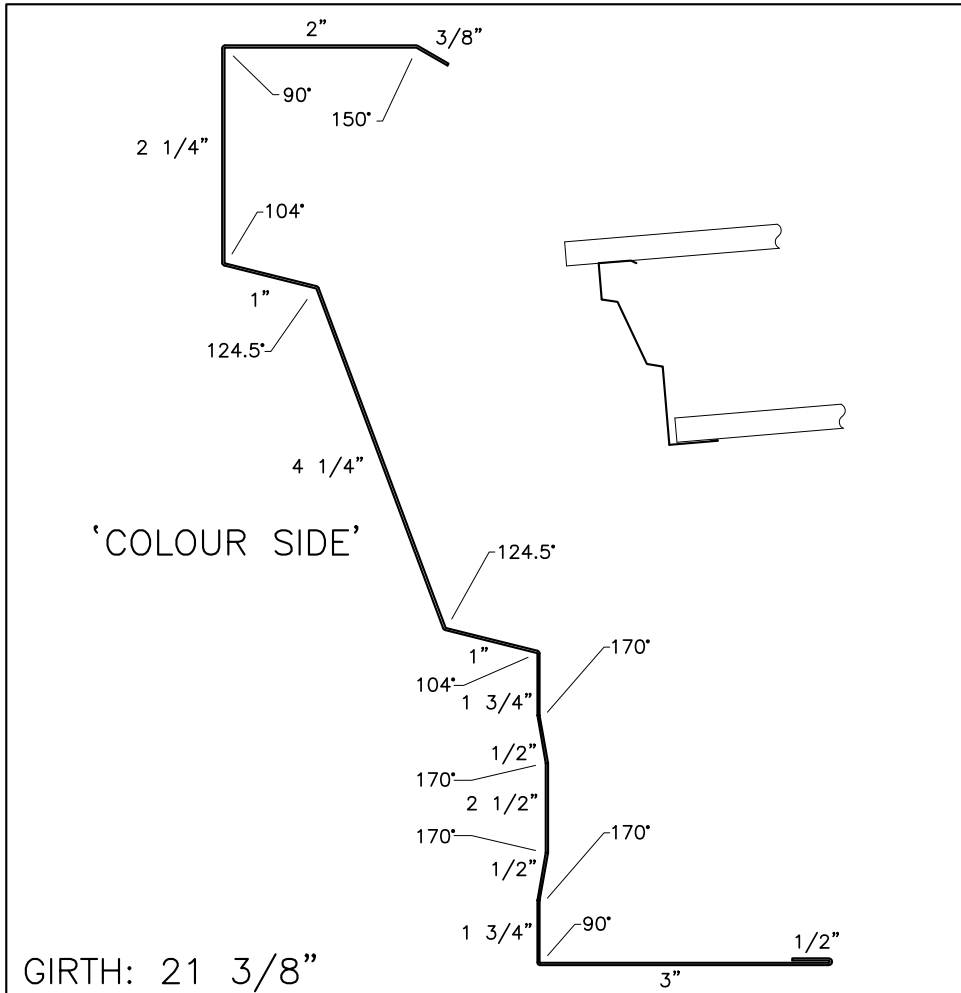

'COLOUR SIDE'

GIRTH: 21 3/8"

GAUGE	WEIGHT
29	1.00#/FT.
28	1.11#/FT.
26	1.34#/FT.
24	1.78#/FT.

exsteel
BUILDING COMPONENTS

7825 Springwater Road
Aylmer, Ontario N5H 2R4
519 - 765 - 2244
www.exsteel.com

DATE: MAY 14/2009	DRAWN: LD
DATE:	CHECKED:
DATE:	PROG:
DATE:	ISSUED:

DESCRIPTION: LOW EAVE OVERHANG TRIM (WITH PROFILE) - 12" PURLIN - 1 1/2" SOFFIT PANEL

DRAWING # **M229**

REV	DESCRIPTION	DATE	BY

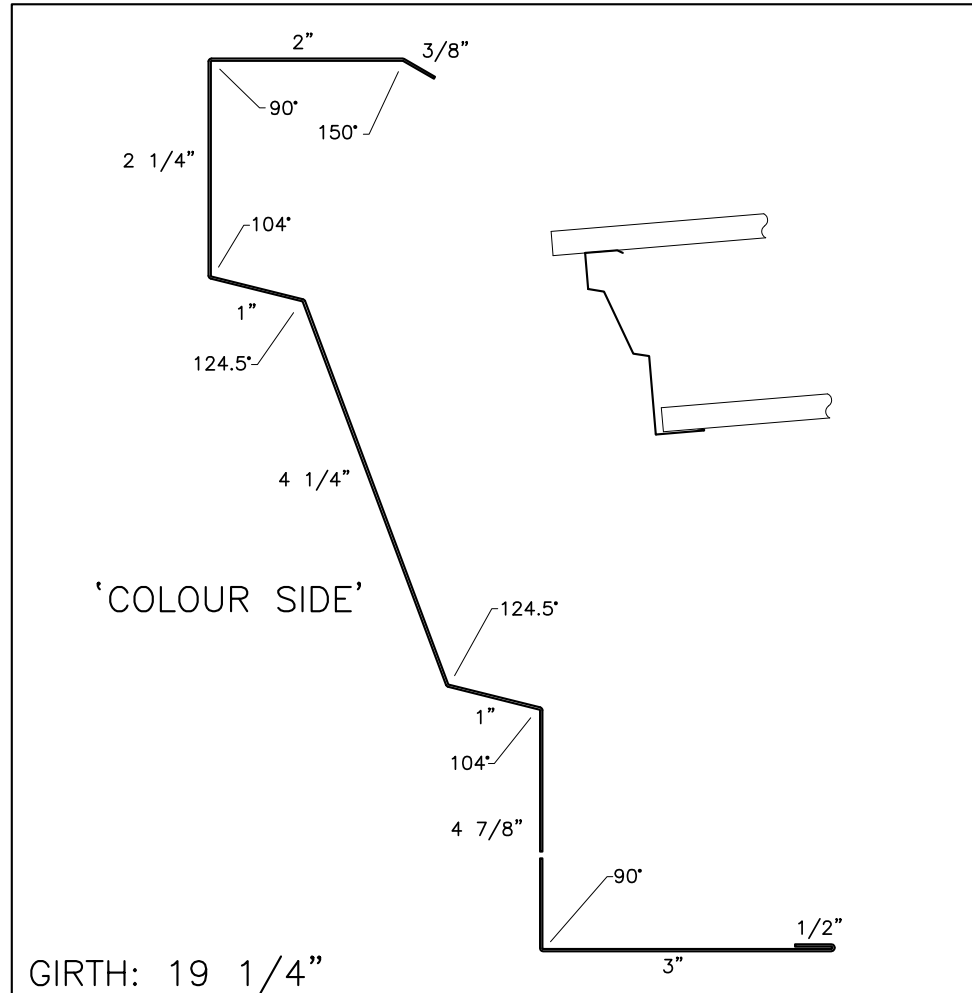

'COLOUR SIDE'

GIRTH: 19 1/4"

GAUGE	WEIGHT
29	0.90#/FT.
28	1.12#/FT.
26	1.30#/FT.
24	1.68#/FT.

exsteel
BUILDING COMPONENTS

7825 Springwater Road
Aylmer, Ontario N5H 2R4
519 - 765 - 2244
www.exsteel.com

DATE: JAN 29/1990	DRAWN: BVERN
DATE:	CHECKED:
DATE:	PROG:
DATE:	ISSUED:

DESCRIPTION: LOW EAVE OVERHANG TRIM (WITH PROFILE) - SCREW DOWN ROOF - 10" PURLIN - 1 1/2" SOFFIT PANEL

DRAWING # **M31**

REV	DESCRIPTION	DATE	BY
1	GENERAL DETAIL REVIEW	JAN 01/09	BJD

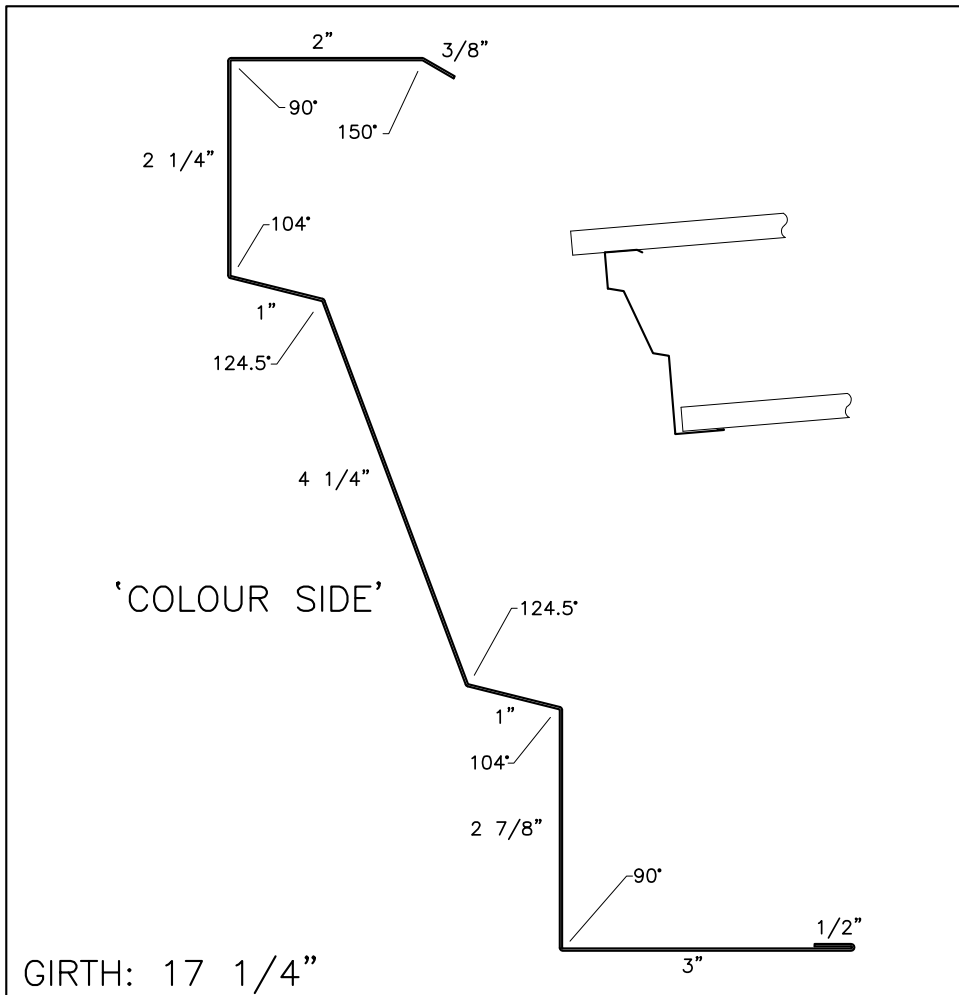

GIRTH: 17 1/4"

GAUGE	WEIGHT
29	0.81#/FT.
28	0.90#/FT.
26	1.08#/FT.
24	1.44#/FT.

		7825 Springwater Road Aylmer, Ontario N5H 2R4 519 - 765 - 2244 www.exsteel.com	
		DATE: MAY 14/2009	DRAWN: LD
DATE:		CHECKED:	
DATE:		PROG:	
DATE:		ISSUED:	
DESCRIPTION: LOW EAVE OVERHANG TRIM (WITH PROFILE) - 8" PURLIN - 1 1/2" SOFFIT PANEL			
DRAWING #		M228	

REV	DESCRIPTION	DATE	BY

PITCH	DESIG.	A°
.25/12	P02	91°
.5/12	P05	92.5°
1/12	P10	94.75°
2/12	P20	99.5°
3/12	P30	104°
4/12	P40	108.5°

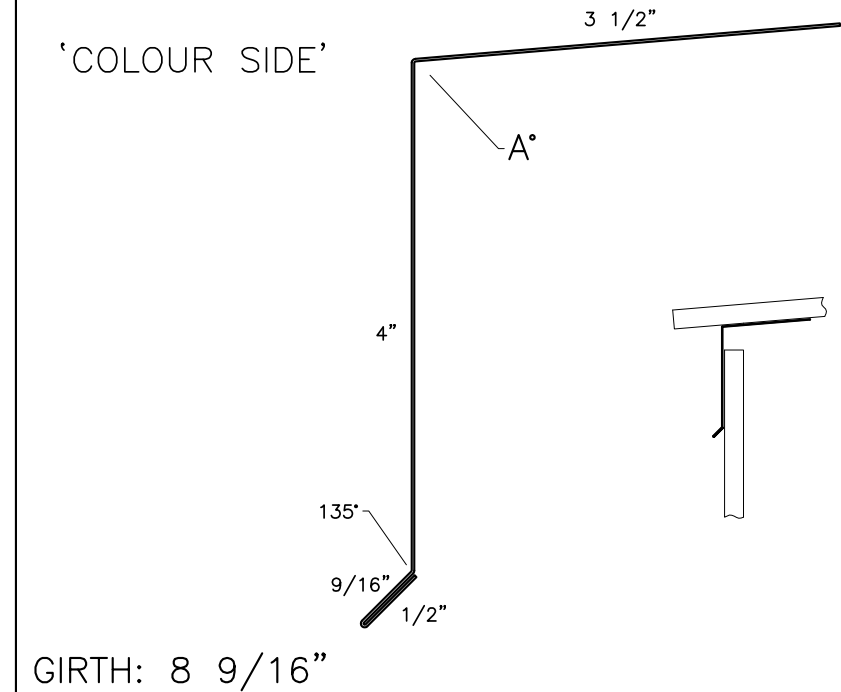

GIRTH: 8 9/16"

GAUGE	WEIGHT
29	0.47#/FT.
28	0.45#/FT.
26	0.54#/FT.
24	0.71#/FT.

		7825 Springwater Road Aylmer, Ontario N5H 2R4 519 - 765 - 2244 www.exsteel.com	
		DATE: JAN 25/1990	DRAWN: BVERN
DATE:		CHECKED:	
DATE:		PROG:	
DATE:		ISSUED:	
DESCRIPTION: LOW EAVE TRIM (WITHOUT PROFILE)			
DRAWING #		M18	

REV	DESCRIPTION	DATE	BY
3	DIMENSION/GIRTH REVISED	MAR 15/11	AF
2	EXTRA MATERIAL REMOVED	JAN 06/11	AF
1	GENERAL DETAIL REVIEW	JAN 01/09	BJD

PITCH	DESIG.	A°
.25/12	P02	91°
.5/12	P05	92.5°
1/12	P10	94.75°
2/12	P20	99.5°
3/12	P30	104°
4/12	P40	108.5°

'COLOUR SIDE'

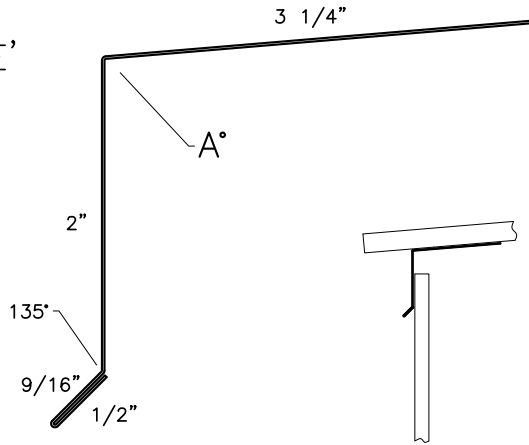

GIRTH: 6 5/16"

GAUGE	WEIGHT
29	0.36#/FT.
28	0.34#/FT.
26	0.41#/FT.
24	0.55#/FT.

		7825 Springwater Road Aylmer, Ontario N5H 2R4 519 - 765 - 2244 www.exsteel.com	
		DATE: JUNE 19/2011	DRAWN: AF
DATE:		CHECKED:	
DATE:		PROG:	
DATE:		ISSUED:	
DESCRIPTION:			
LOW EAVE TRIM (WITHOUT PROFILE) - SCREW DOWN ROOF - 5/8"-3/4" PANEL			
DRAWING #		M284	

REV	DESCRIPTION	DATE	BY
2	REVISED DIMENSION/GIRTH	SEP 05/11	AF
1	GENERAL DETAIL REVIEW	JUN 19/11	AF

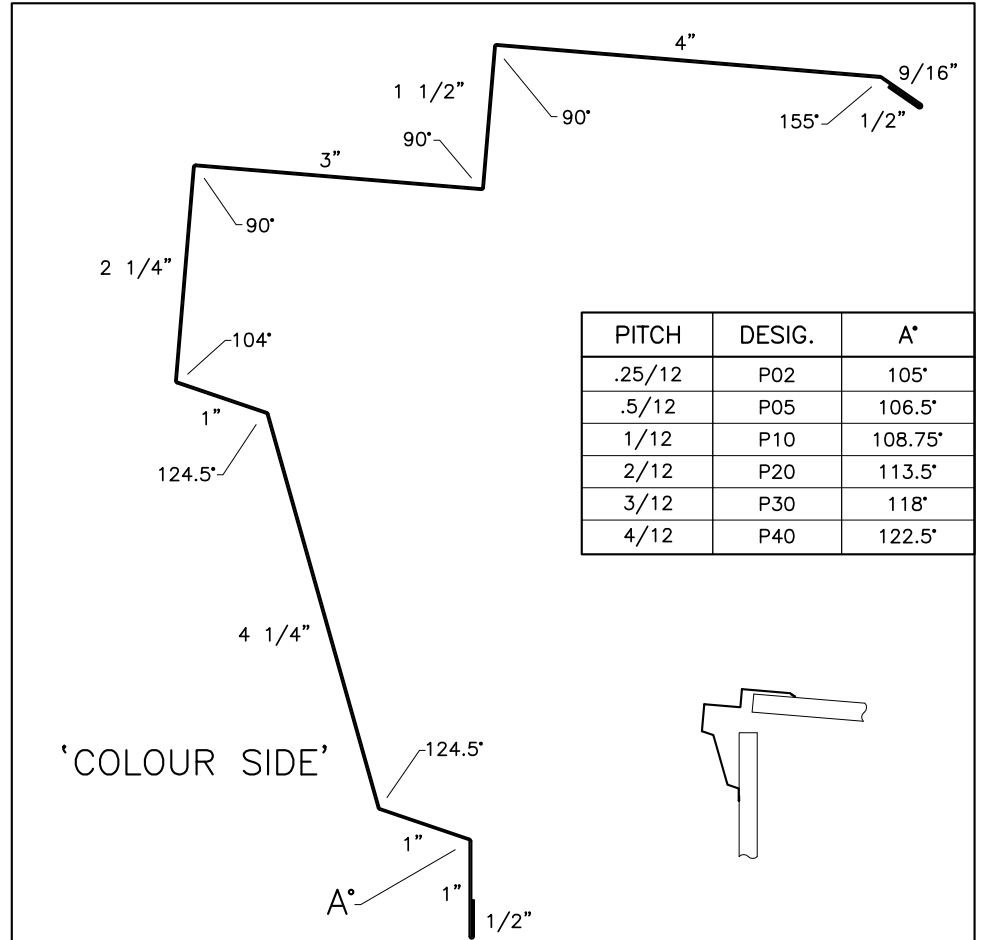

PITCH	DESIG.	A°
.25/12	P02	105°
.5/12	P05	106.5°
1/12	P10	108.75°
2/12	P20	113.5°
3/12	P30	118°
4/12	P40	122.5°

'COLOUR SIDE'

GIRTH: 19 9/16"

GAUGE	WEIGHT
29	0.98#/FT.
28	1.12#/FT.
26	1.31#/FT.
24	1.69#/FT.

		7825 Springwater Road Aylmer, Ontario N5H 2R4 519 - 765 - 2244 www.exsteel.com	
		DATE: JAN 24/1990	DRAWN: BVERN
DATE:		CHECKED:	
DATE:		PROG:	
DATE:		ISSUED:	
DESCRIPTION:			
HIGH EAVE TRIM (WITH PROFILE) - SCREW DOWN ROOF - 1 1/2" WALL PANEL			
DRAWING #		M11	

REV	DESCRIPTION	DATE	BY
1	GENERAL DETAIL REVIEW	JAN 01/09	BJD

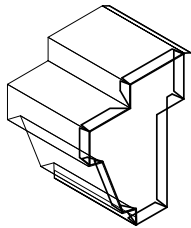
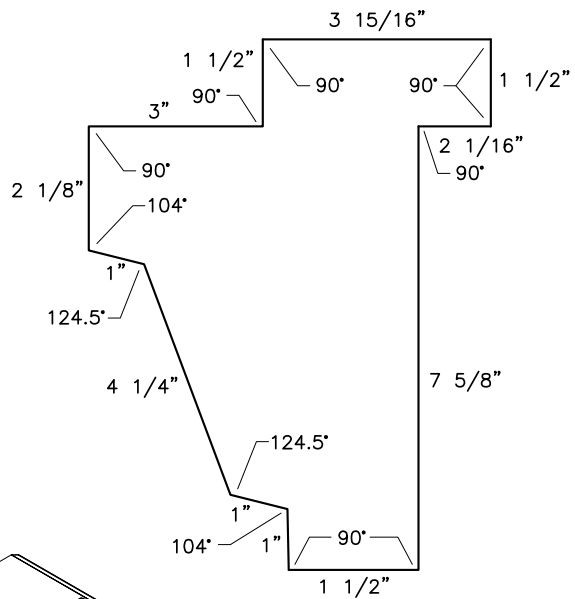

GAUGE	WEIGHT
29	1.88# ea.
28	2.07# ea.
26	2.49# ea.
24	3.32# ea.

 BUILDING COMPONENTS	7825 Springwater Road Aylmer, Ontario N5H 2R4 519 - 765 - 2244 www.exsteel.com			
	DATE: DEC 03/2009	DRAWN: AF		
	DATE:	CHECKED:		
	DATE:	PROG:		
	DATE:	ISSUED:		
DESCRIPTION: END CAP -- HIGH EAVE (M11) -- RIGHT				
1	GENERAL DETAIL REVIEW	JAN 01/09	BJD	DRAWING # M90
REV	DESCRIPTION	DATE	BY	

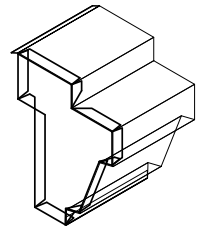
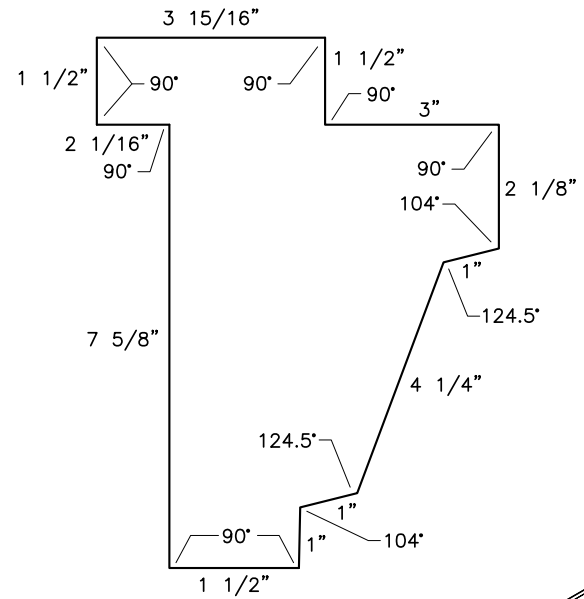

GAUGE	WEIGHT
29	1.88# ea.
28	2.07# ea.
26	2.49# ea.
24	3.32# ea.

 BUILDING COMPONENTS	7825 Springwater Road Aylmer, Ontario N5H 2R4 519 - 765 - 2244 www.exsteel.com			
	DATE: DEC 03/2009	DRAWN: AF		
	DATE:	CHECKED:		
	DATE:	PROG:		
	DATE:	ISSUED:		
DESCRIPTION: END CAP -- HIGH EAVE (M11) -- LEFT				
1	GENERAL DETAIL REVIEW	JAN 01/09	BJD	DRAWING # M91
REV	DESCRIPTION	DATE	BY	

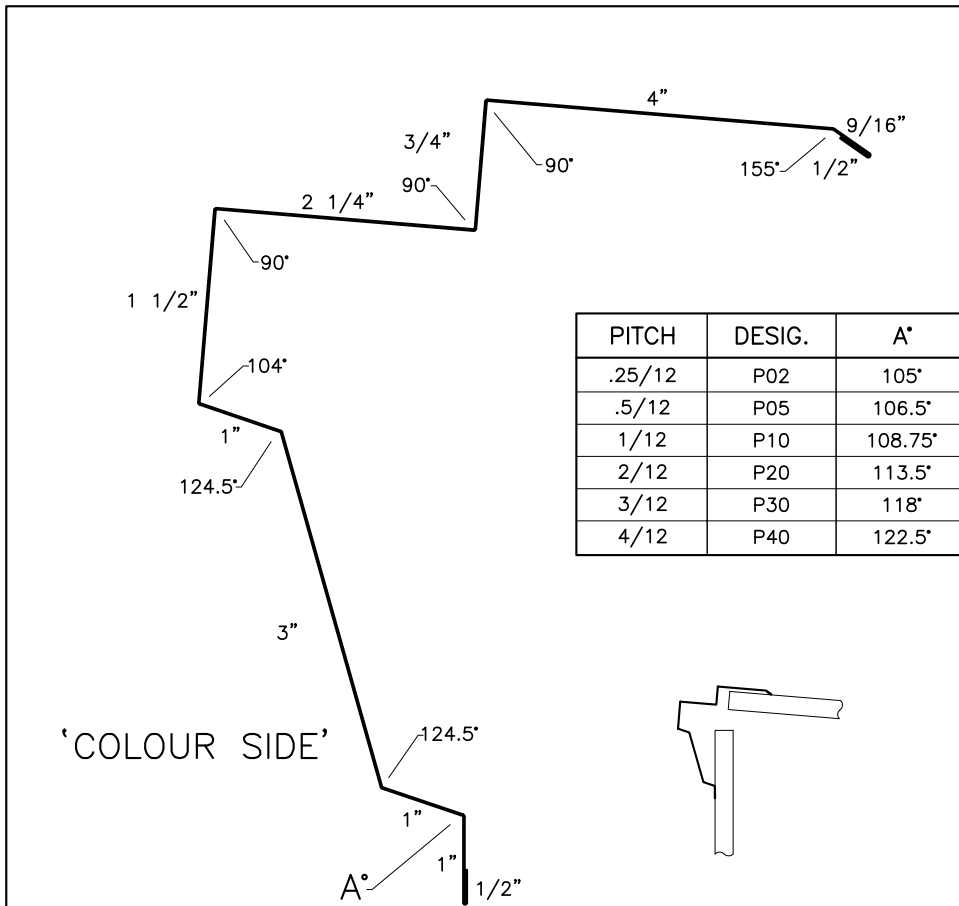

PITCH	DESIG.	A°
.25/12	P02	105°
.5/12	P05	106.5°
1/12	P10	108.75°
2/12	P20	113.5°
3/12	P30	118°
4/12	P40	122.5°

'COLOUR SIDE'

GIRTH: 16 1/16"

GAUGE	WEIGHT
29	0.76#/FT.
28	0.92#/FT.
26	1.08#/FT.
24	1.39#/FT.

exsteel
BUILDING COMPONENTS

7825 Springwater Road
Aylmer, Ontario N5H 2R4
519 - 765 - 2244
www.exsteel.com

DATE: MAR 28/2006	DRAWN: SB
DATE:	CHECKED:
DATE:	PROG:
DATE:	ISSUED:

DESCRIPTION: HIGH EAVE TRIM (WITH PROFILE)
- 5/8"-3/4" SCREW DOWN
ROOF - 5/8"-3/4" WALL PANEL

DRAWING # **M144**

REV	DESCRIPTION	DATE	BY
1	GENERAL DETAIL REVIEW	JAN 01/09	BJD

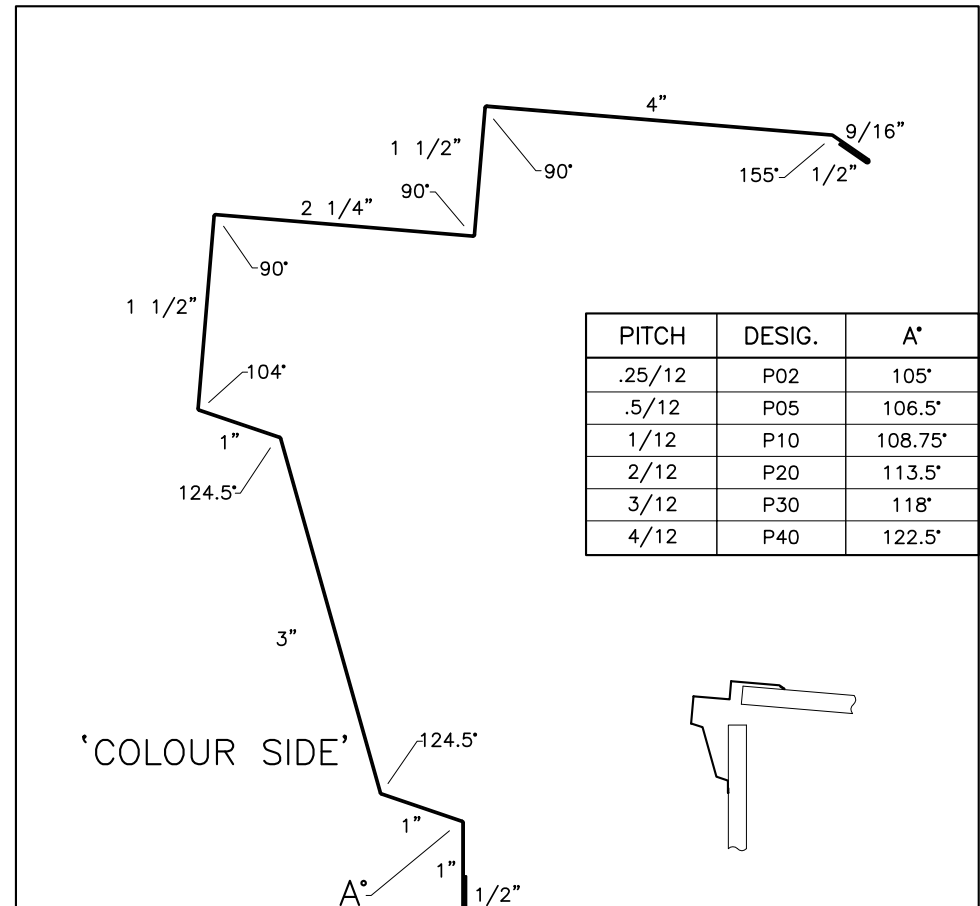

PITCH	DESIG.	A°
.25/12	P02	105°
.5/12	P05	106.5°
1/12	P10	108.75°
2/12	P20	113.5°
3/12	P30	118°
4/12	P40	122.5°

'COLOUR SIDE'

GIRTH: 16 13/16"

GAUGE	WEIGHT
29	0.79#/FT.
28	0.96#/FT.
26	1.13#/FT.
24	1.45#/FT.

exsteel
BUILDING COMPONENTS

7825 Springwater Road
Aylmer, Ontario N5H 2R4
519 - 765 - 2244
www.exsteel.com

DATE: MAR 28/2006	DRAWN: SB
DATE:	CHECKED:
DATE:	PROG:
DATE:	ISSUED:

DESCRIPTION: HIGH EAVE TRIM (WITH PROFILE)
- 1 1/2" SCREW DOWN ROOF
- 5/8"-3/4" WALL PANEL

DRAWING # **M145**

REV	DESCRIPTION	DATE	BY
1	GENERAL DETAIL REVIEW	JAN 01/09	BJD

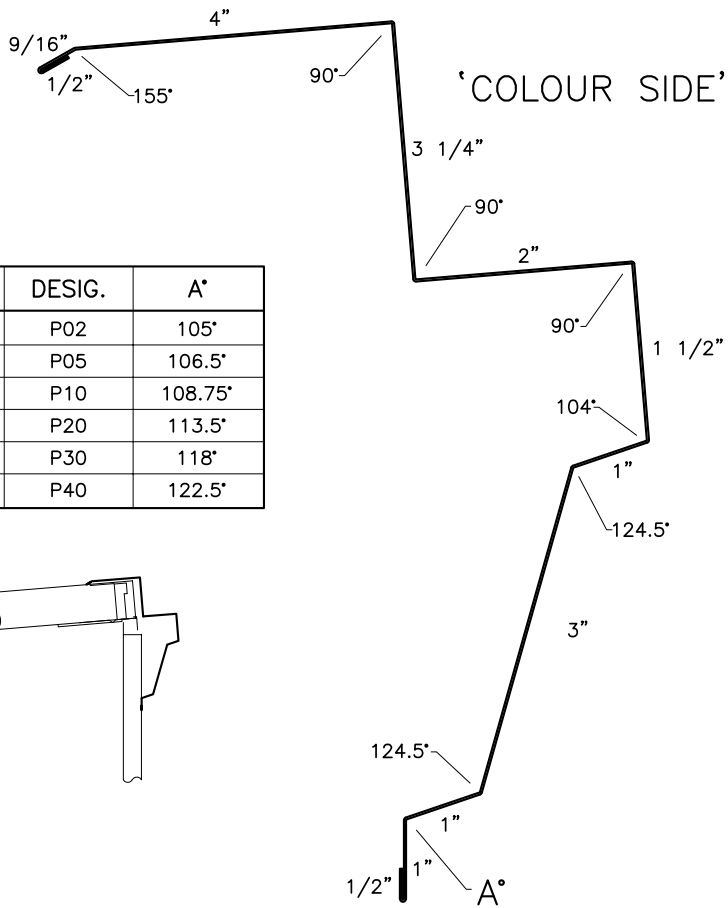

'COLOUR SIDE'

PITCH	DESIG.	A°
.25/12	P02	105°
.5/12	P05	106.5°
1/12	P10	108.75°
2/12	P20	113.5°
3/12	P30	118°
4/12	P40	122.5°

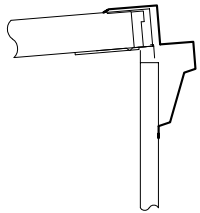

GIRTH: 18 5/16"

GAUGE	WEIGHT
29	0.86#/FT.
28	1.05#/FT.
26	1.23#/FT.
24	1.58#/FT.

		7825 Springwater Road Aylmer, Ontario N5H 2R4 519 - 765 - 2244 www.exsteel.com	
		DATE: MAR 28/2006	DRAWN: SB
DATE:		CHECKED:	
DATE:		PROG:	
DATE:		ISSUED:	
DESCRIPTION:			
HIGH EAVE TRIM (WITH PROFILE) - RTL-24 - 5/8"-3/4" WALL PANEL			
DRAWING #		M147	

REV	DESCRIPTION	DATE	BY
1	GENERAL DETAIL REVIEW	JAN 01/09	BJD

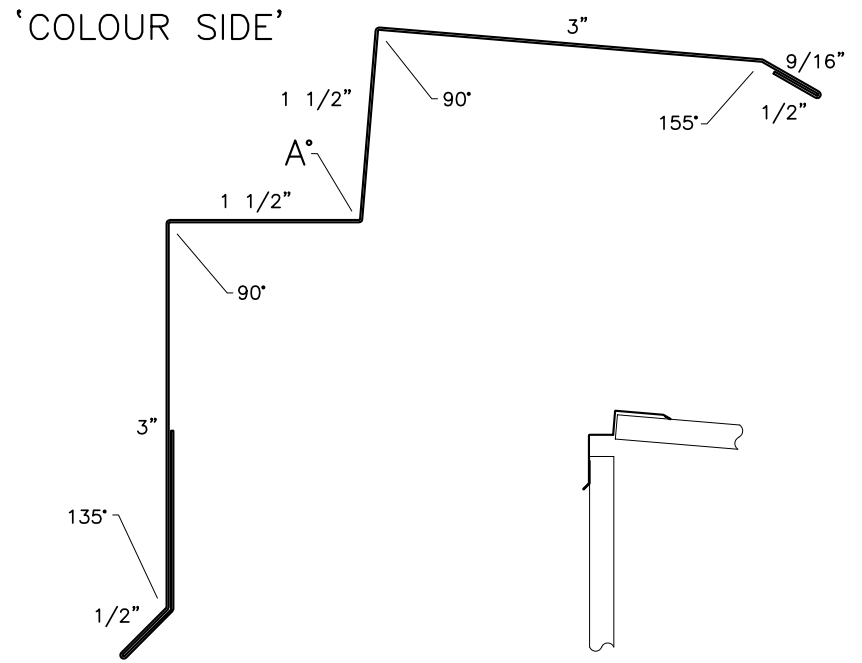

'COLOUR SIDE'

PITCH	DESIG.	A°
.25/12	P02	91°
.5/12	P05	92.5°
1/12	P10	94.75°
2/12	P20	99.5°
3/12	P30	104°
4/12	P40	108.5°

GIRTH: 12 9/16"

GAUGE	WEIGHT
29	0.59#/FT.
28	0.72#/FT.
26	0.84#/FT.
24	1.09#/FT.

		7825 Springwater Road Aylmer, Ontario N5H 2R4 519 - 765 - 2244 www.exsteel.com	
		DATE: JAN 25/1990	DRAWN: BVERN
DATE:		CHECKED:	
DATE:		PROG:	
DATE:		ISSUED:	
DESCRIPTION:			
HIGH EAVE TRIM (WITHOUT PROFILE) - SCREW DOWN ROOF			
DRAWING #		M20	

REV	DESCRIPTION	DATE	BY
1	GENERAL DETAIL REVIEW	JAN 01/09	BJD

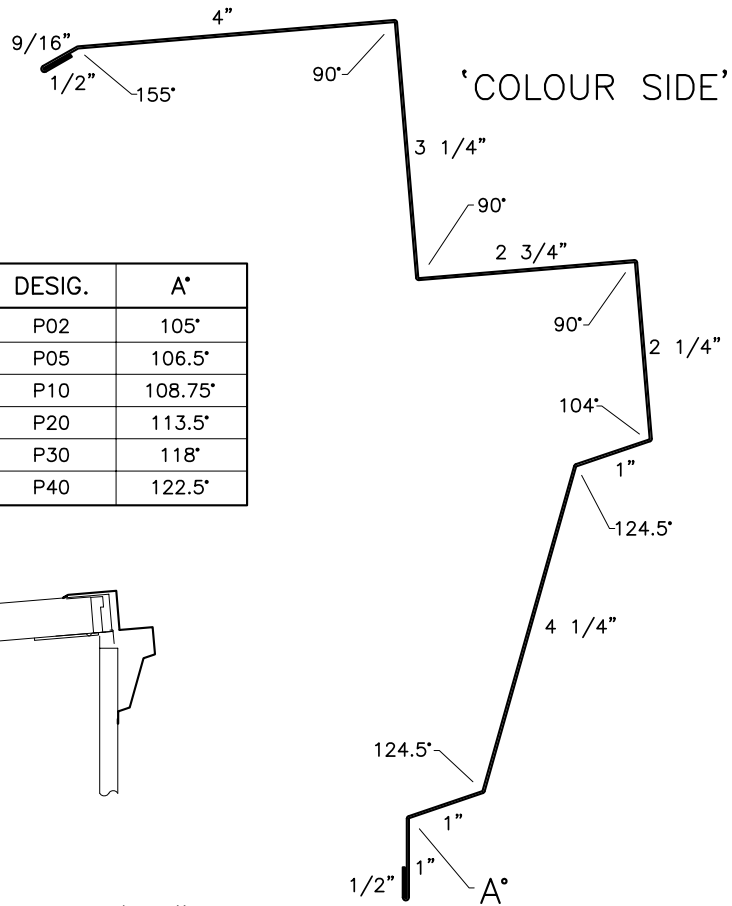

PITCH	DESIG.	A°
.25/12	P02	105°
.5/12	P05	106.5°
1/12	P10	108.75°
2/12	P20	113.5°
3/12	P30	118°
4/12	P40	122.5°

GIRTH: 21 1/16"

GAUGE	WEIGHT
29	1.06#/FT.
28	1.21#/FT.
26	1.41#/FT.
24	1.82#/FT.

exsteel
BUILDING COMPONENTS

7825 Springwater Road
Aylmer, Ontario N5H 2R4
519 - 765 - 2244
www.exsteel.com

DATE: JAN 25/1990	DRAWN: BVERN
DATE:	CHECKED:
DATE:	PROG:
DATE:	ISSUED:

DESCRIPTION: HIGH EAVE TRIM - RTL-24
- 1 1/2" WALL PANEL

DRAWING # **M24**

REV	DESCRIPTION	DATE	BY
1	GENERAL DETAIL REVIEW	JAN 01/09	BJD

'COLOUR SIDE'

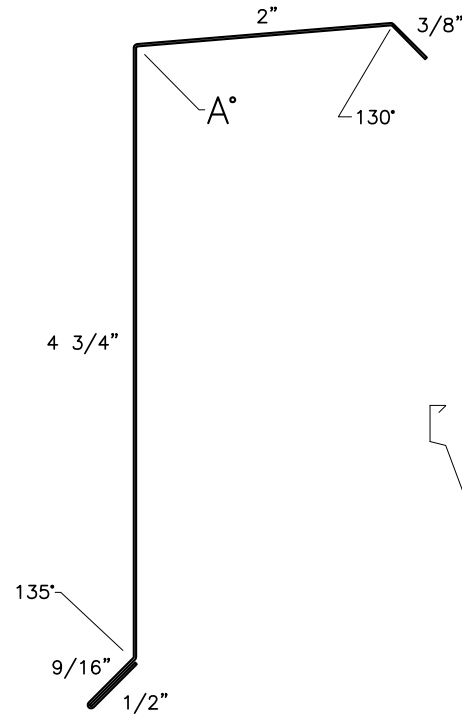

GIRTH: 8 3/16"

GAUGE	WEIGHT
29	0.45#/FT.
28	0.43#/FT.
26	0.51#/FT.
24	0.68#/FT.

REV	DESCRIPTION	DATE	BY
3	DIMENSION/GIRTH REVISED	MAR 15/11	AF
2	EXTRA MATERIAL REMOVED	JAN 11/11	AF
1	GENERAL DETAIL REVIEW	JAN 01/09	BJD

PITCH	DESIG.	A°
.25/12	P02	91°
.5/12	P05	92.5°
1/12	P10	94.75°
2/12	P20	99.5°
3/12	P30	104°
4/12	P40	108.5°

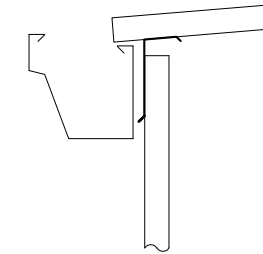

exsteel
BUILDING COMPONENTS

7825 Springwater Road
Aylmer, Ontario N5H 2R4
519 - 765 - 2244
www.exsteel.com

DATE: JAN 24/1990	DRAWN: BVERN
DATE:	CHECKED:
DATE:	PROG:
DATE:	ISSUED:

DESCRIPTION: FLASHING BEHIND GUTTER

DRAWING # **M09**

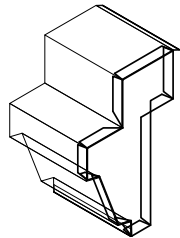
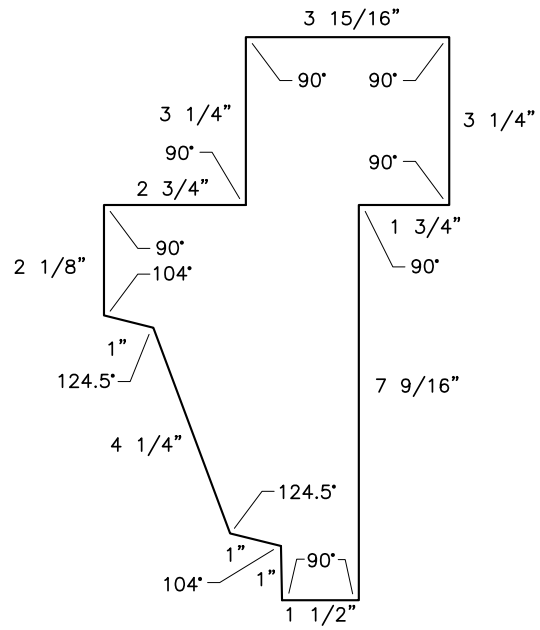

GAUGE	WEIGHT
29	1.88# ea.
28	2.07# ea.
26	2.49# ea.
24	3.32# ea.

exsteel BUILDING COMPONENTS	7825 Springwater Road Aylmer, Ontario N5H 2R4 519 - 765 - 2244 www.exsteel.com	
	DATE: DEC 03/2009	DRAWN: AF
	DATE:	CHECKED:
	DATE:	PROG:
DATE:	ISSUED:	

DESCRIPTION:
END CAP -- HIGH EAVE (M24) -- RIGHT

REV	DESCRIPTION	DATE	BY
1	GENERAL DETAIL REVIEW	JAN 01/09	BJD

DRAWING # M106

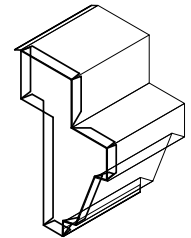
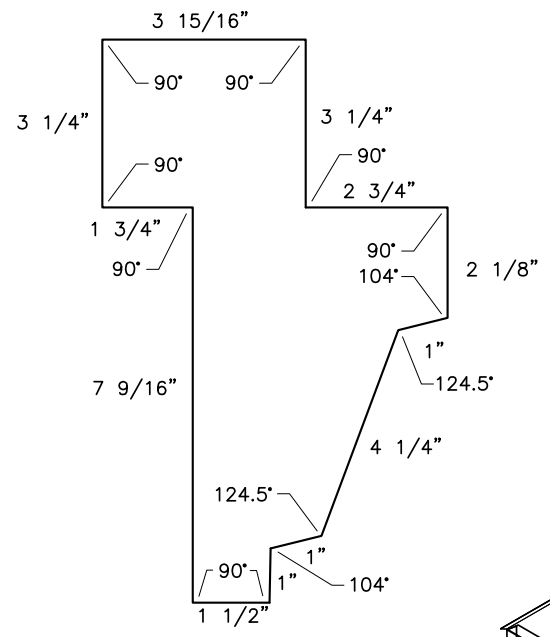

GAUGE	WEIGHT
29	1.88# ea.
28	2.07# ea.
26	2.49# ea.
24	3.32# ea.

exsteel BUILDING COMPONENTS	7825 Springwater Road Aylmer, Ontario N5H 2R4 519 - 765 - 2244 www.exsteel.com	
	DATE: DEC 03/2009	DRAWN: AF
	DATE:	CHECKED:
	DATE:	PROG:
DATE:	ISSUED:	

DESCRIPTION:
END CAP -- HIGH EAVE (M24) -- LEFT

REV	DESCRIPTION	DATE	BY
1	GENERAL DETAIL REVIEW	JAN 01/09	BJD

DRAWING # M107

PITCH	DESIG.	A°
.25/12	P02	92°
.5/12	P05	93°
1/12	P10	95°
2/12	P20	100°
3/12	P30	104°
4/12	P40	109°

'COLOUR SIDE'

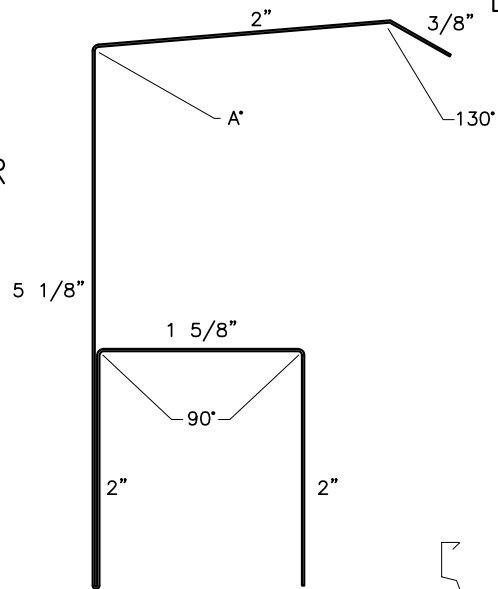

GIRTH: 13 1/8"

GAUGE	WEIGHT
29	0.61#/FT.
28	0.77#/FT.
26	0.90#/FT.
24	1.21#/FT.

		7825 Springwater Road Aylmer, Ontario N5H 2R4 519 - 765 - 2244 www.exsteel.com	
		DATE: NOV 26/1997	DRAWN: BJD
DATE:		CHECKED:	
DATE:		PROG:	
DATE:		ISSUED:	
DESCRIPTION: FLASHING BEHIND GUTTER - 1 1/2" WALL PANEL			
DRAWING #		M102	

REV	DESCRIPTION	DATE	BY
1	GENERAL DETAIL REVIEW	JAN 01/09	BJD

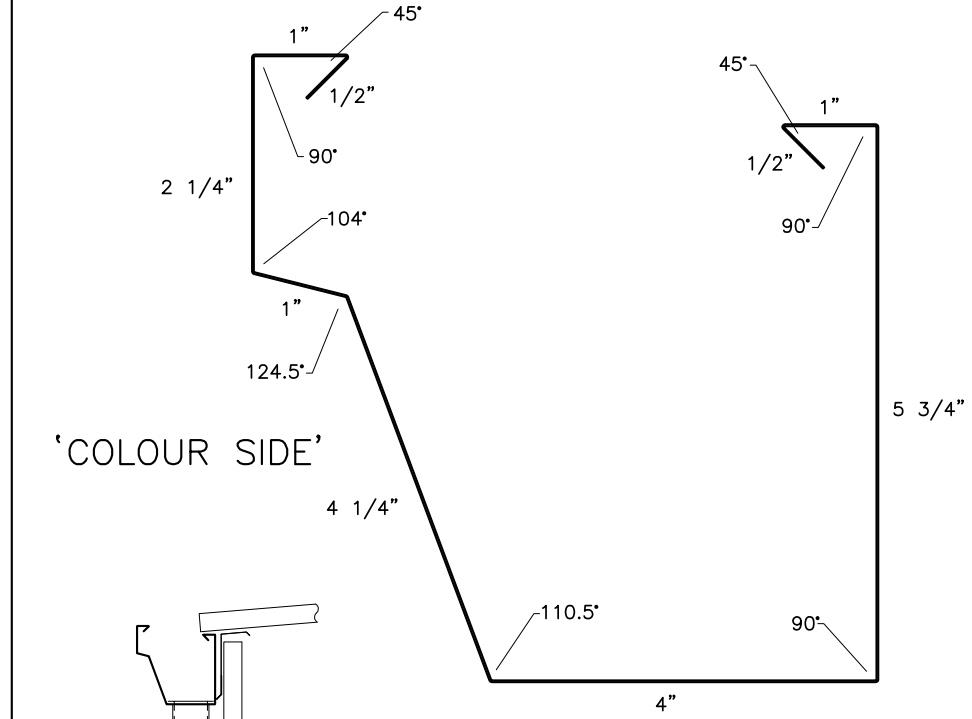

'COLOUR SIDE'

GIRTH: 20 1/4"

GAUGE	WEIGHT
29	1.04#/FT.
28	1.18#/FT.
26	1.38#/FT.
24	1.78#/FT.

		7825 Springwater Road Aylmer, Ontario N5H 2R4 519 - 765 - 2244 www.exsteel.com	
		DATE: JAN 24/1990	DRAWN: BVERN
DATE:		CHECKED:	
DATE:		PROG:	
DATE:		ISSUED:	
DESCRIPTION: GUTTER - SCREW DOWN ROOF			
DRAWING #		M12	

REV	DESCRIPTION	DATE	BY
1	GENERAL DETAIL REVIEW	JAN 01/09	BJD

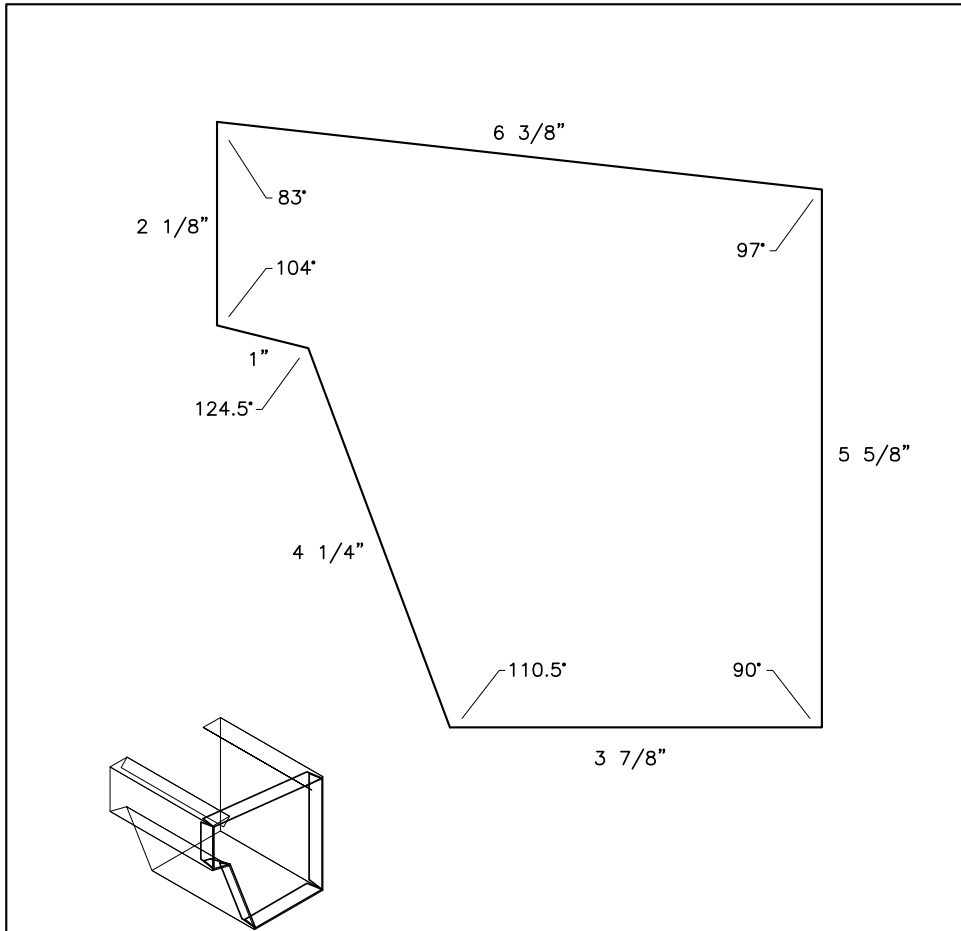

GAUGE	WEIGHT
29	0.38# ea.
28	0.41# ea.
26	0.50# ea.
24	0.66# ea.

 BUILDING COMPONENTS	7825 Springwater Road Aylmer, Ontario N5H 2R4 519 - 765 - 2244 www.exsteel.com			
	DATE: DEC 03/2009	DRAWN: AF		
	DATE:	CHECKED:		
	DATE:	PROG:		
	DATE:	ISSUED:		
DESCRIPTION: END CAP - GUTTER (M12) - RIGHT				
1	GENERAL DETAIL REVIEW	JAN 01/09	BJD	DRAWING # M50
REV	DESCRIPTION	DATE	BY	

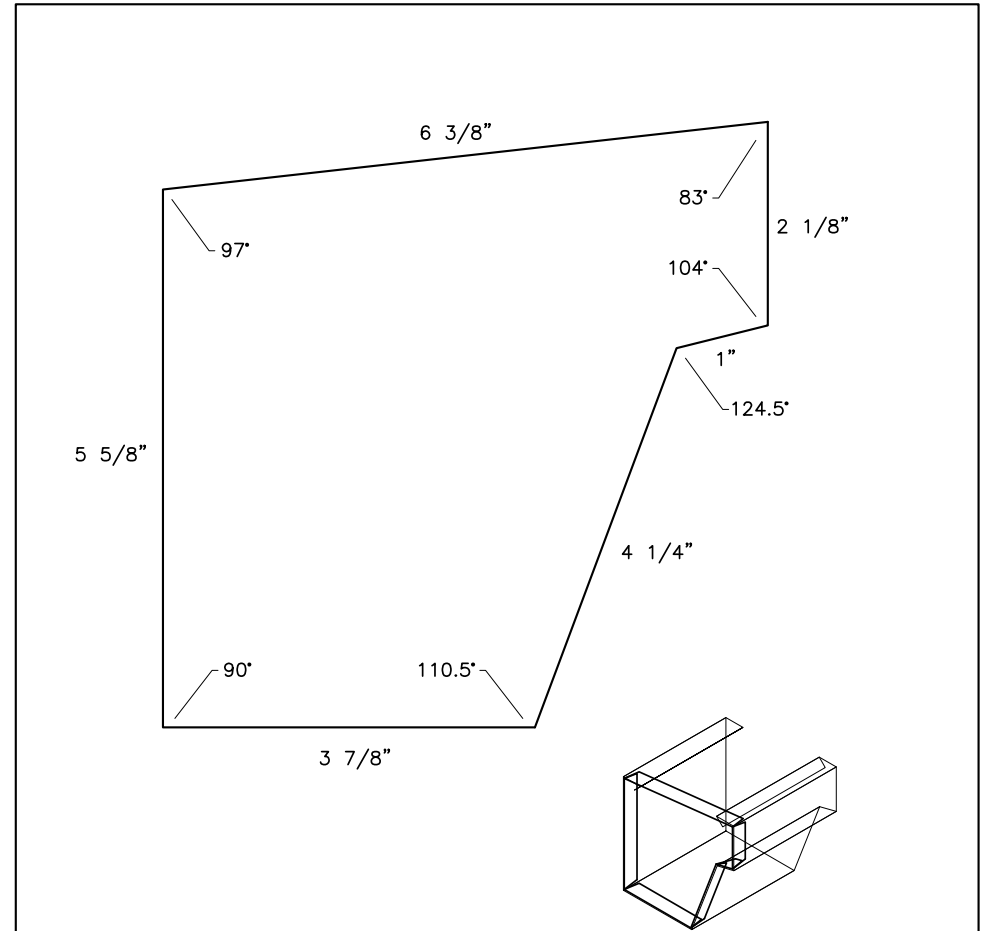

GAUGE	WEIGHT
29	0.38# ea.
28	0.41# ea.
26	0.50# ea.
24	0.66# ea.

 BUILDING COMPONENTS	7825 Springwater Road Aylmer, Ontario N5H 2R4 519 - 765 - 2244 www.exsteel.com			
	DATE: DEC 03/2009	DRAWN: AF		
	DATE:	CHECKED:		
	DATE:	PROG:		
	DATE:	ISSUED:		
DESCRIPTION: END CAP - GUTTER (M12) - LEFT				
1	GENERAL DETAIL REVIEW	JAN 01/09	BJD	DRAWING # M51
REV	DESCRIPTION	DATE	BY	

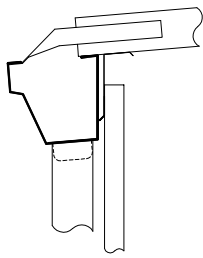

PITCH	DESIG.	A°	B°
.25/12	P02	89°	91°
.5/12	P05	87.5°	92.5°
1/12	P10	85.25°	94.75°
2/12	P20	80.5°	99.5°
3/12	P30	76°	104°

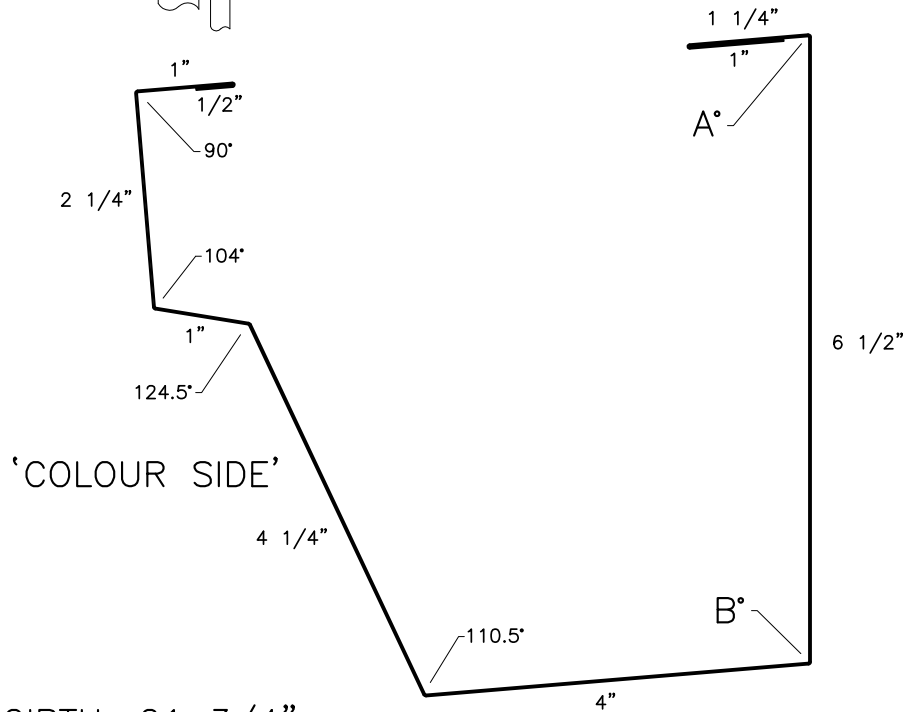

GIRTH: 21 3/4"

GAUGE	WEIGHT
29	1.07#/FT.
28	1.23#/FT.
26	1.43#/FT.
24	1.84#/FT.

		7825 Springwater Road Aylmer, Ontario N5H 2R4 519 - 765 - 2244 www.exsteel.com	
		DATE: APR 5/2004	DRAWN: IMO
DATE:		CHECKED:	
DATE:		PROG:	
DATE:		ISSUED:	
DESCRIPTION: GUTTER - RTL-24 - 3:12 SLOPE AND BELOW			
DRAWING #		M139	

REV	DESCRIPTION	DATE	BY
1	GENERAL DETAIL REVIEW	JAN 01/09	BJD

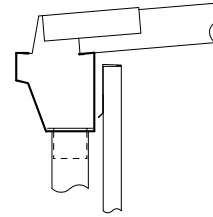

PITCH	DESIG.	A°
.25/12	P02	89°
.5/12	P05	87.5°
1/12	P10	85.25°
2/12	P20	80.5°
3/12	P30	76°
4/12	P40	71.5°

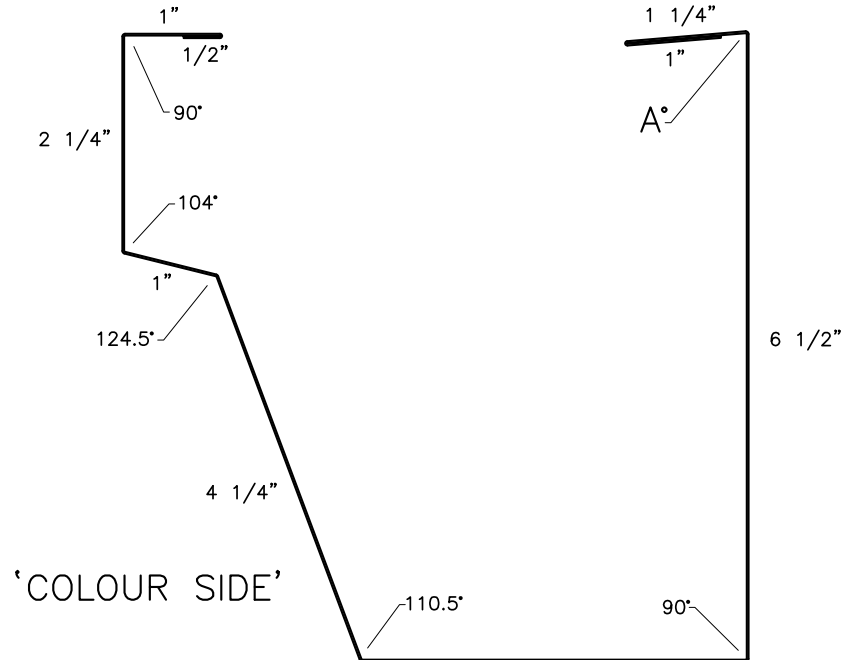

GIRTH: 21 3/4"

GAUGE	WEIGHT
29	1.02#/FT.
28	1.23#/FT.
26	1.43#/FT.
24	1.84#/FT.

		7825 Springwater Road Aylmer, Ontario N5H 2R4 519 - 765 - 2244 www.exsteel.com	
		DATE: JAN 24/1990	DRAWN: BVERN
DATE:		CHECKED:	
DATE:		PROG:	
DATE:		ISSUED:	
DESCRIPTION: GUTTER - RTL-24 - OVER 4:12 SLOPE			
DRAWING #		M13	

REV	DESCRIPTION	DATE	BY
1	GENERAL DETAIL REVIEW	JAN 01/09	BJD

PITCH	DESIG.	A°	B°	C°	D"
.25/12	P02	90.2°	88.6°	91.2°	6 7/16"
.5/12	P05	90.2°	87.4°	92.4°	6 5/8"
1/12	P10	90.0°	85.2°	94.8°	6 7/8"
2/12	P20	89.5°	81.0°	99.5°	7 3/8"
3/12	P30	88.8°	77.2°	104.0°	7 7/8"

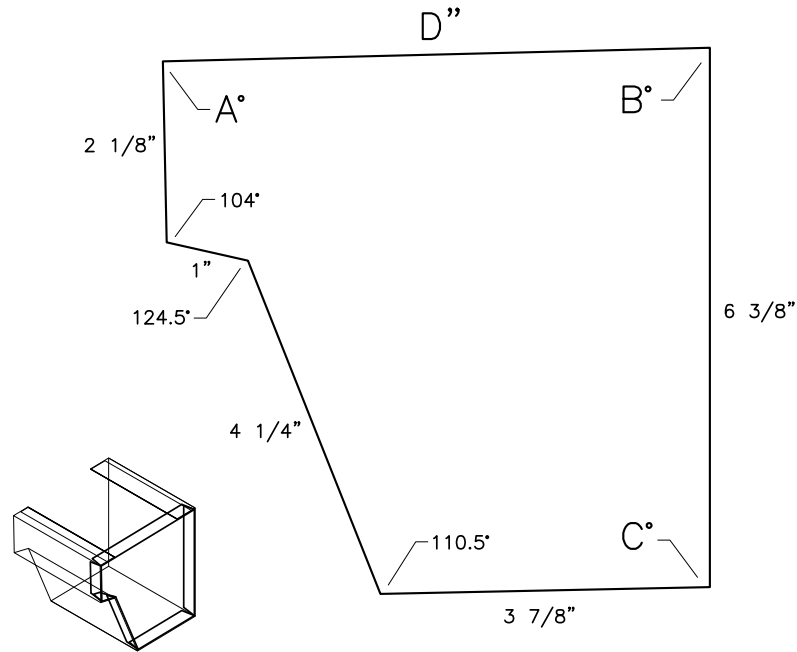

GAUGE	WEIGHT
29	0.38# ea.
28	0.41# ea.
26	0.50# ea.
24	0.66# ea.

		7825 Springwater Road Aylmer, Ontario N5H 2R4 519 - 765 - 2244 www.exsteel.com	
		DATE: DEC 03/2009	DRAWN: AF
DATE:		CHECKED:	
DATE:		PROG:	
DATE:		ISSUED:	
DESCRIPTION:			
GUTTER CAP (M13/M139) – RIGHT			
DRAWING #		M52	
1	GENERAL DETAIL REVIEW	JAN 01/09	BJD
REV	DESCRIPTION	DATE	BY

PITCH	DESIG.	A°	B°	C°	D"
.25/12	P02	90.2°	88.6°	91.2°	6 7/16"
.5/12	P05	90.2°	87.4°	92.4°	6 5/8"
1/12	P10	90.0°	85.2°	94.8°	6 7/8"
2/12	P20	89.5°	81.0°	99.5°	7 3/8"
3/12	P30	88.8°	77.2°	104.0°	7 7/8"

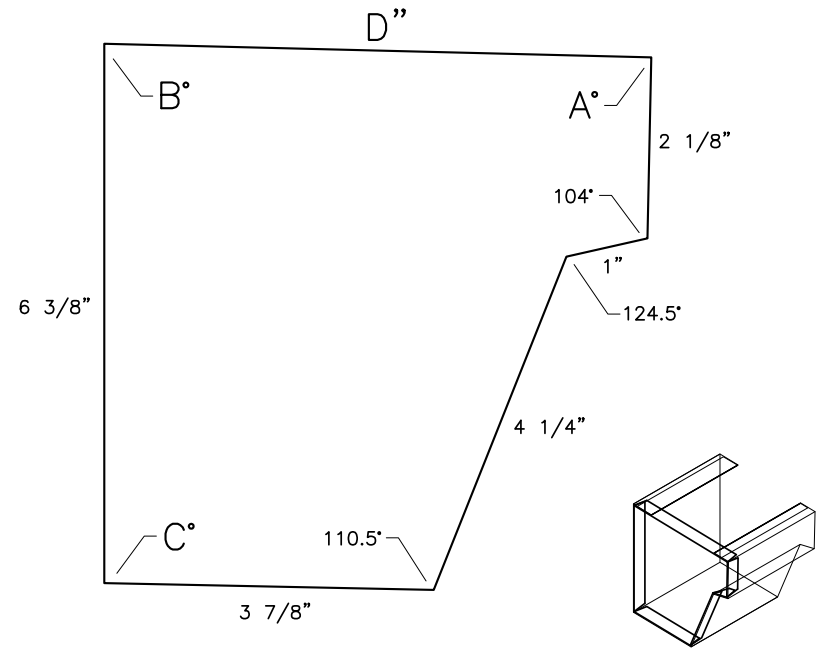

GAUGE	WEIGHT
29	0.38# ea.
28	0.41# ea.
26	0.50# ea.
24	0.66# ea.

		7825 Springwater Road Aylmer, Ontario N5H 2R4 519 - 765 - 2244 www.exsteel.com	
		DATE: DEC 03/2009	DRAWN: AF
DATE:		CHECKED:	
DATE:		PROG:	
DATE:		ISSUED:	
DESCRIPTION:			
GUTTER CAP (M13/M139) – LEFT			
DRAWING #		M53	
1	GENERAL DETAIL REVIEW	JAN 01/09	BJD
REV	DESCRIPTION	DATE	BY

'COLOUR SIDE'

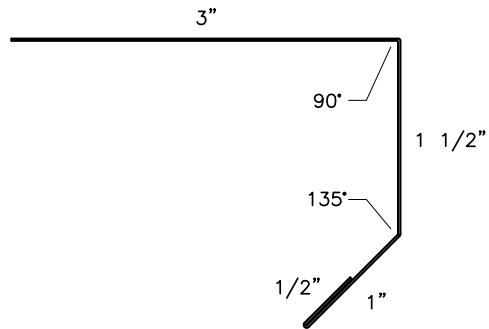

GIRTH: 6"

GAUGE	WEIGHT
29	0.28#/FT.
28	0.30#/FT.
26	0.37#/FT.
24	0.49#/FT.

exsteel BUILDING COMPONENTS		7825 Springwater Road Aylmer, Ontario N5H 2R4 519 - 765 - 2244 www.exsteel.com	
DATE:	MAR 24/2010	DRAWN:	AF
DATE:		CHECKED:	
DATE:		PROG:	
DATE:		ISSUED:	

DESCRIPTION: RE-ROOF EDGE TRIM

REV	DESCRIPTION	DATE	BY
1	GENERAL DETAIL REVIEW	MAR 24/10	LD

DRAWING # M245

'COLOUR SIDE'

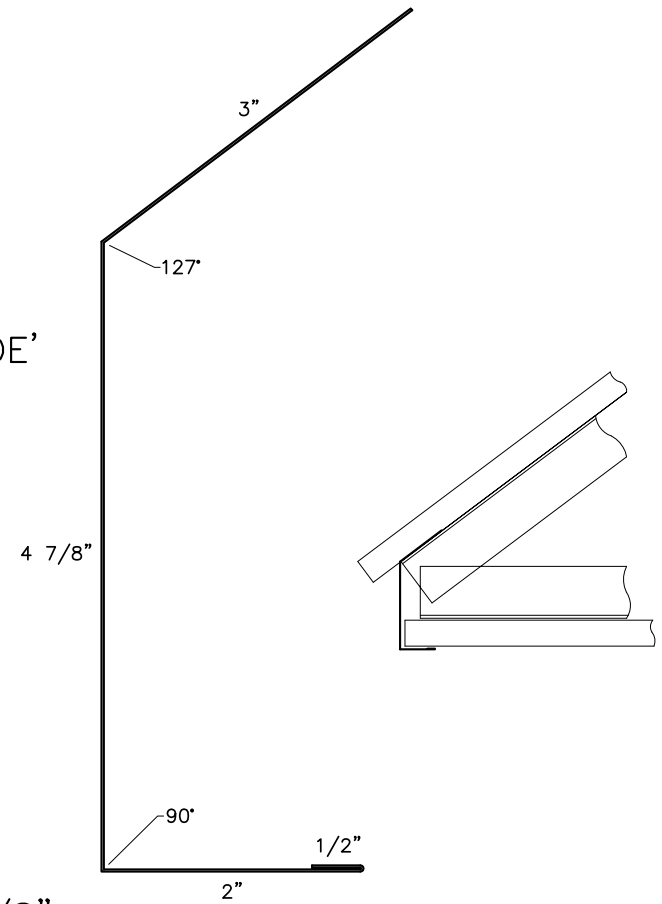

GIRTH: 10 3/8"

GAUGE	WEIGHT
29	0.49#/FT.
28	0.54#/FT.
26	0.65#/FT.
24	0.86#/FT.

exsteel BUILDING COMPONENTS		7825 Springwater Road Aylmer, Ontario N5H 2R4 519 - 765 - 2244 www.exsteel.com	
DATE:	JAN 23/2001	DRAWN:	IMO
DATE:		CHECKED:	
DATE:		PROG:	
DATE:		ISSUED:	

DESCRIPTION: CANOPY FASCIA TRIM

REV	DESCRIPTION	DATE	BY
1	GENERAL DETAIL REVIEW	JAN 01/09	BJD

DRAWING # M118

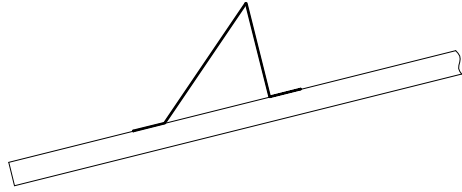

'COLOUR SIDE'

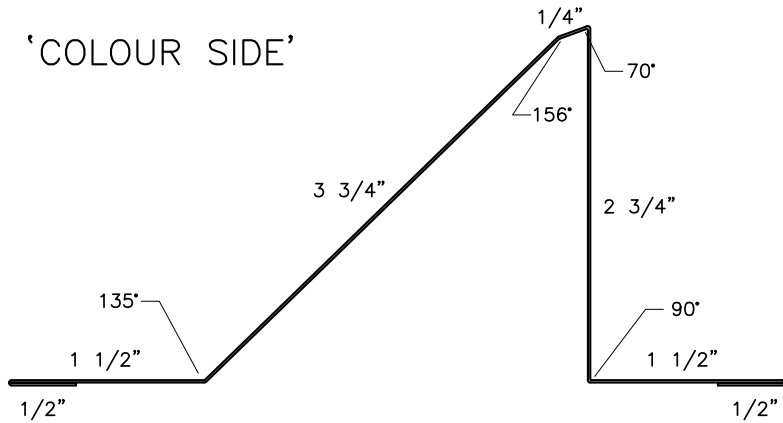

GIRTH: 10 3/4"

GAUGE	WEIGHT
29	0.53#/FT.
28	0.66#/FT.
26	0.79#/FT.
24	1.06#/FT.

		7825 Springwater Road Aylmer, Ontario N5H 2R4 519-765-2244 www.exsteel.com	
		DATE: MAR 22/2010	DRAWN: AF
DATE:		CHECKED:	
DATE:		PROG:	
DATE:		ISSUED:	
DESCRIPTION: SNOW GUARD			
DRAWING #		M243	

REV	DESCRIPTION	DATE	BY
3	GENERAL REVISION	SEP 05/11	AF
2	REVISED DIMENSIONS/GIRTH	JAN 12/11	AF
1	GENERAL DETAIL REVIEW	OCT 14/10	LD

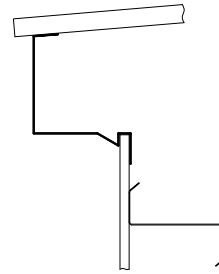

PITCH	DESIG.	A°
.25/12	P02	91°
.5/12	P05	92°
1/12	P10	94°
2/12	P20	99°
3/12	P30	104°
4/12	P40	108°

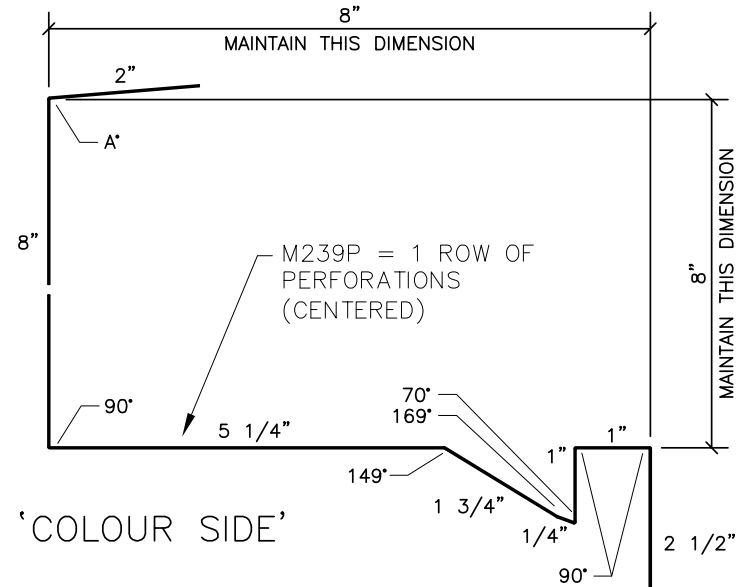

'COLOUR SIDE'

GIRTH: 21 3/4"

GAUGE	WEIGHT
29	0.88#/FT.
28	1.10#/FT.
26	1.32#/FT.
24	1.77#/FT.

		7825 Springwater Road Aylmer, Ontario N5H 2R4 519-765-2244 www.exsteel.com	
		DATE: JAN 27/2010	DRAWN: AF
DATE:		CHECKED:	
DATE:		PROG:	
DATE:		ISSUED:	
DESCRIPTION: EAVE - 8" SOFFIT/8" FASCIA TRIM - SCREW DOWN ROOF - 5/8"-3/4" PANEL			
DRAWING #		M239/M239P	

REV	DESCRIPTION	DATE	BY
4	REVISED DIMENSIONS/ANGLES	SEP 05/11	AF
3	GENERAL REVISION	DEC 16/10	AF
2	DIMENSION AND GIRTH REVISED	DEC 02/10	LD
1	GENERAL DETAIL REVIEW	JAN 27/10	LD

PITCH	DESIG.	A°
.25/12	P02	91°
.5/12	P05	92°
1/12	P10	94°
2/12	P20	99°
3/12	P30	104°
4/12	P40	108°

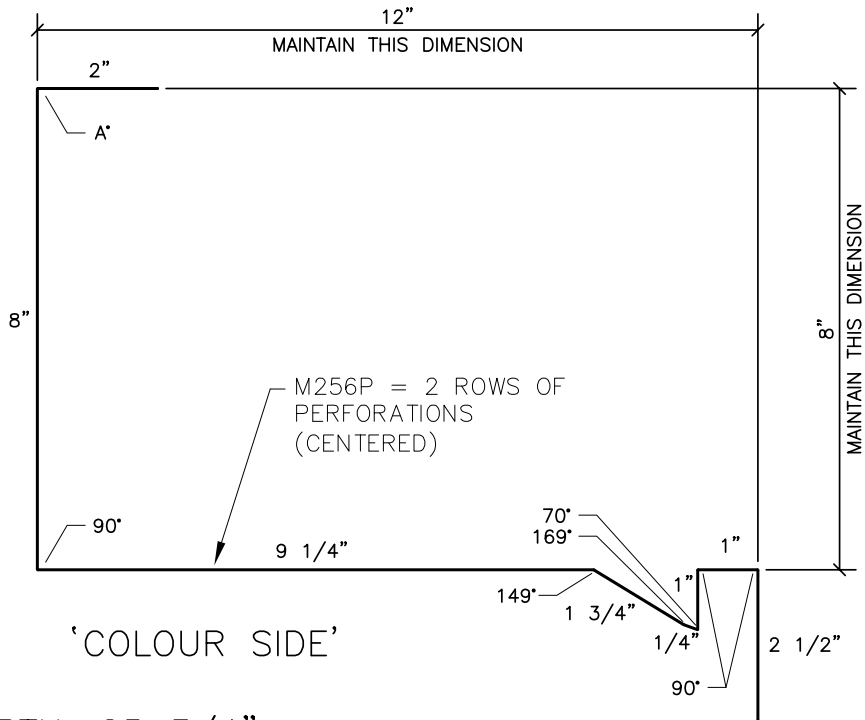

GIRTH: 25 3/4"

GAUGE	WEIGHT
29	2.15#/FT.
28	1.61#/FT.
26	1.35#/FT.
24	1.40#/FT.

		7825 Springwater Road Aylmer, Ontario N5H 2R4 519 - 765 - 2244 www.exsteel.com	
		DATE: JUNE 21/2011	DRAWN: AF
DATE:		CHECKED:	
DATE:		PROG:	
DATE:		ISSUED:	
DESCRIPTION: EAVE - 12" SOFFIT/8" FASCIA TRIM - SCREW DOWN ROOF - 5/8"-3/4" PANEL			
DRAWING #		M256/M256P	

REV	DESCRIPTION	DATE	BY
1	GENERAL DETAIL REVIEW	OCT 25/11	AF

PITCH	DESIG.	A°
.25/12	P02	91°
.5/12	P05	92°
1/12	P10	94°
2/12	P20	99°
3/12	P30	104°
4/12	P40	108°

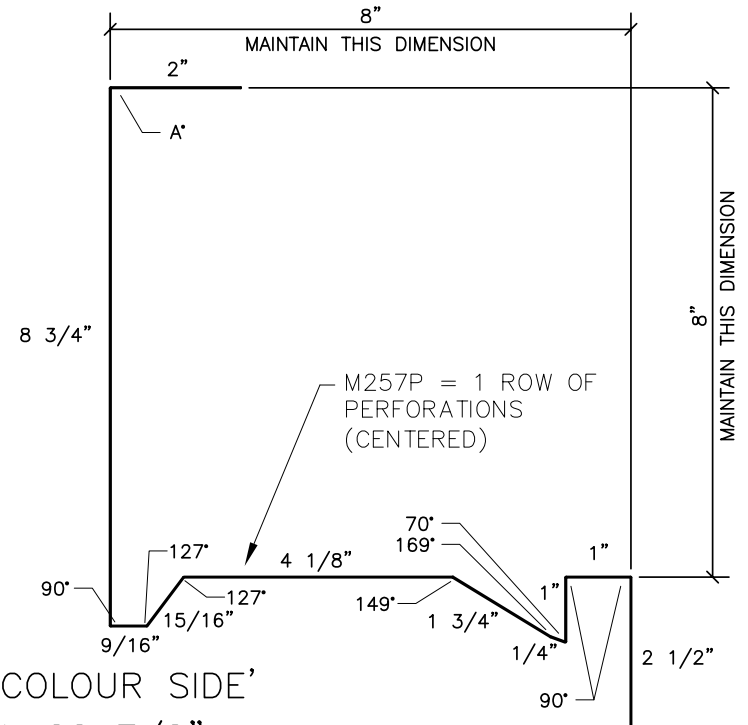

GIRTH: 22 7/8"

GAUGE	WEIGHT
29	2.15#/FT.
28	1.61#/FT.
26	1.35#/FT.
24	1.40#/FT.

		7825 Springwater Road Aylmer, Ontario N5H 2R4 519 - 765 - 2244 www.exsteel.com	
		DATE: JUNE 21/2011	DRAWN: AF
DATE:		CHECKED:	
DATE:		PROG:	
DATE:		ISSUED:	
DESCRIPTION: EAVE - 8" SOFFIT/8" FASCIA TRIM WITH DRIP - SCREW DOWN ROOF - 5/8"-3/4" PANEL			
DRAWING #		M257/M257P	

REV	DESCRIPTION	DATE	BY
1	GENERAL DETAIL REVIEW	OCT 25/11	AF

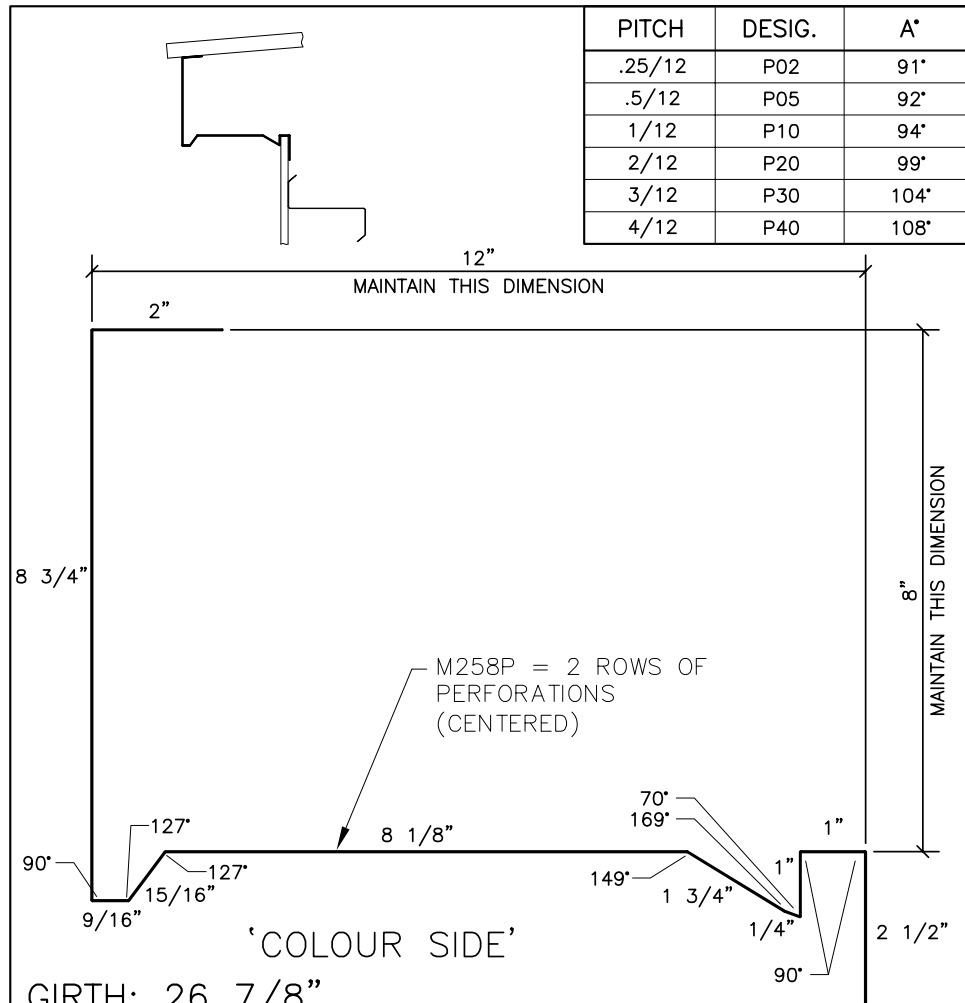

GAUGE	WEIGHT
29	2.24#/FT.
28	1.68#/FT.
26	1.40#/FT.
24	1.46#/FT.

exsteel
BUILDING COMPONENTS

7825 Springwater Road
Aylmer, Ontario N5H 2R4
519 - 765 - 2244
www.exsteel.com

DATE: JUNE 21/2011	DRAWN: AF
DATE:	CHECKED:
DATE:	PROG:
DATE:	ISSUED:

DESCRIPTION: EAVE - 12" SOFFIT/8" FASCIA TRIM WITH DRIP - SCREW DOWN ROOF - 5/8"-3/4" PANEL

DRAWING # **M258/M258P**

REV	DESCRIPTION	DATE	BY
1	GENERAL DETAIL REVIEW	OCT 25/11	AF

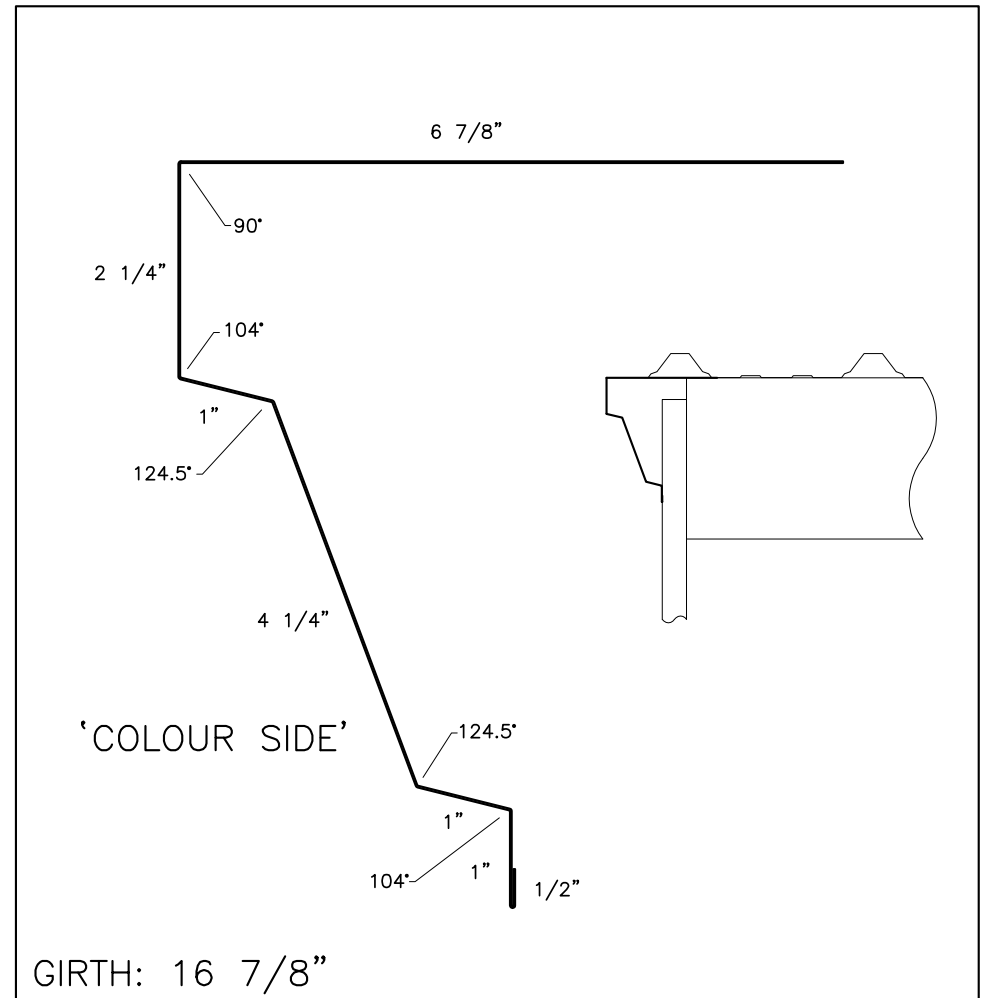

GAUGE	WEIGHT
29	0.85#/FT.
28	0.98#/FT.
26	1.14#/FT.
24	1.47#/FT.

exsteel
BUILDING COMPONENTS

7825 Springwater Road
Aylmer, Ontario N5H 2R4
519 - 765 - 2244
www.exsteel.com

DATE: JAN 23/1990	DRAWN: BVERN
DATE:	CHECKED:
DATE:	PROG:
DATE:	ISSUED:

DESCRIPTION: GABLE TRIM (WITH PROFILE) - SCREW DOWN ROOF - UP TO 1 1/2" WALL PANEL

DRAWING # **M03**

REV	DESCRIPTION	DATE	BY
1	GENERAL DETAIL REVIEW	JAN 01/09	BJD

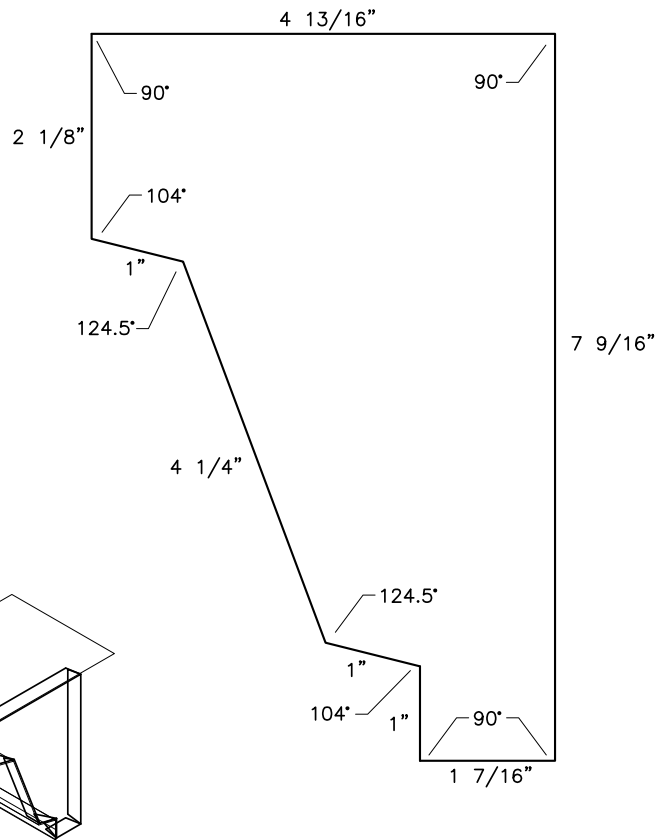

GAUGE	WEIGHT
29	1.88# ea.
28	2.07# ea.
26	2.49# ea.
24	3.32# ea.

		7825 Springwater Road Aylmer, Ontario N5H 2R4 519 - 765 - 2244 www.exsteel.com	
		DATE: DEC 03/2009	DRAWN: AF
DATE:		CHECKED:	
DATE:		PROG:	
DATE:		ISSUED:	
DESCRIPTION: END CAP - GABLE (M03) - EAVE (M02) - RIGHT			
DRAWING #		M61	
1	GENERAL DETAIL REVIEW	JAN 01/09	BJD
REV	DESCRIPTION	DATE	BY

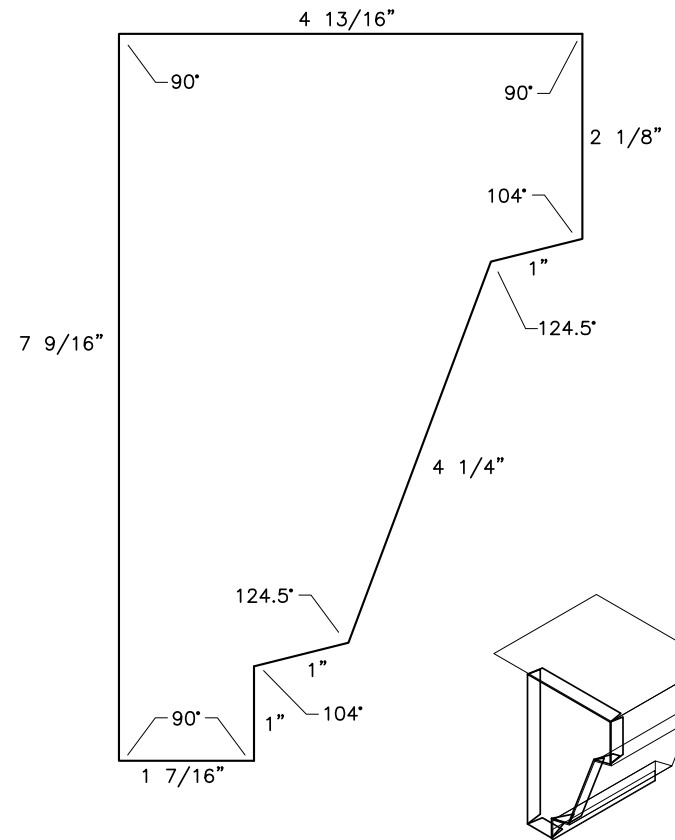

GAUGE	WEIGHT
29	1.88# ea.
28	2.07# ea.
26	2.49# ea.
24	3.32# ea.

		7825 Springwater Road Aylmer, Ontario N5H 2R4 519 - 765 - 2244 www.exsteel.com	
		DATE: DEC 03/2009	DRAWN: AF
DATE:		CHECKED:	
DATE:		PROG:	
DATE:		ISSUED:	
DESCRIPTION: END CAP - GABLE (M03) - EAVE (M02) - LEFT			
DRAWING #		M62	
1	GENERAL DETAIL REVIEW	JAN 01/09	BJD
REV	DESCRIPTION	DATE	BY

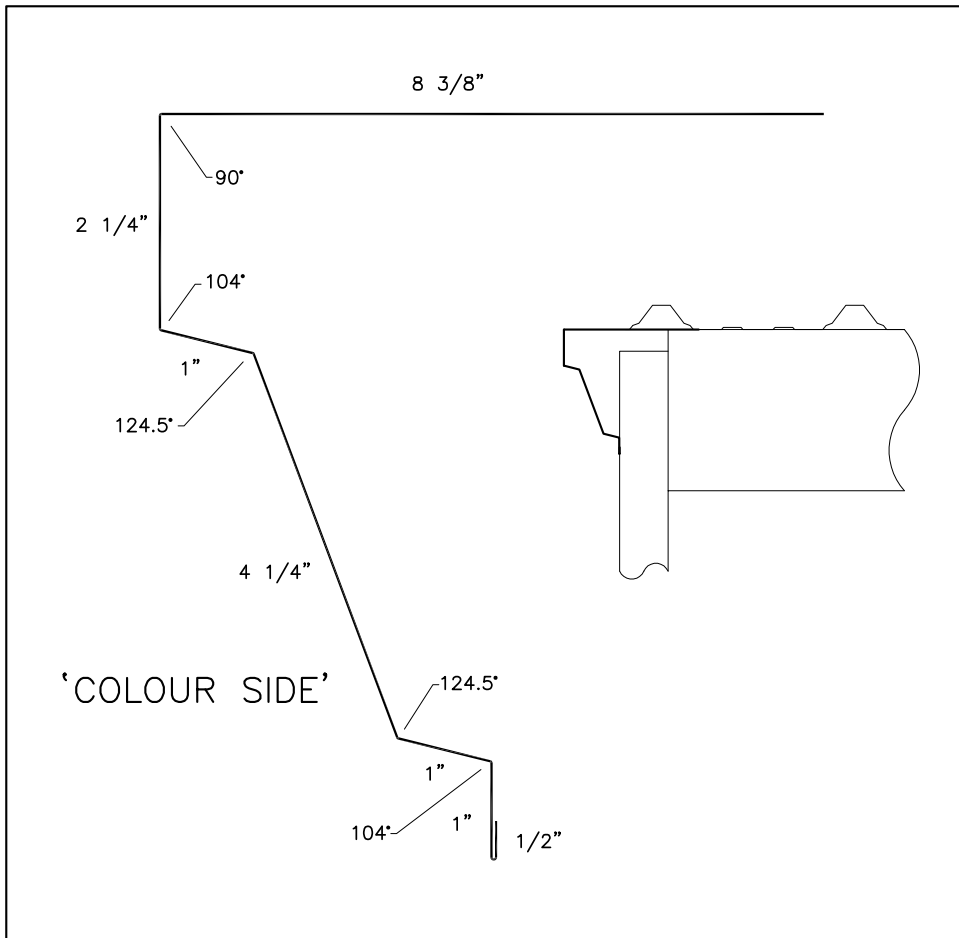

GIRTH: 18 3/8"

GAUGE	WEIGHT
29	0.86#/FT.
28	1.06#/FT.
26	1.24#/FT.
24	1.60#/FT.

		7825 Springwater Road Aylmer, Ontario N5H 2R4 519 - 765 - 2244 www.exsteel.com	
		DATE: MAR 2/1994	DRAWN: BVERN
DATE:		CHECKED:	
DATE:		PROG:	
DATE:		ISSUED:	

DESCRIPTION:
 GABLE TRIM (WITH PROFILE) - SCREW
 DOWN ROOF - 3" WALL PANEL

1	GENERAL DETAIL REVIEW	JAN 01/09	BJD
REV	DESCRIPTION	DATE	BY

DRAWING # **M48**

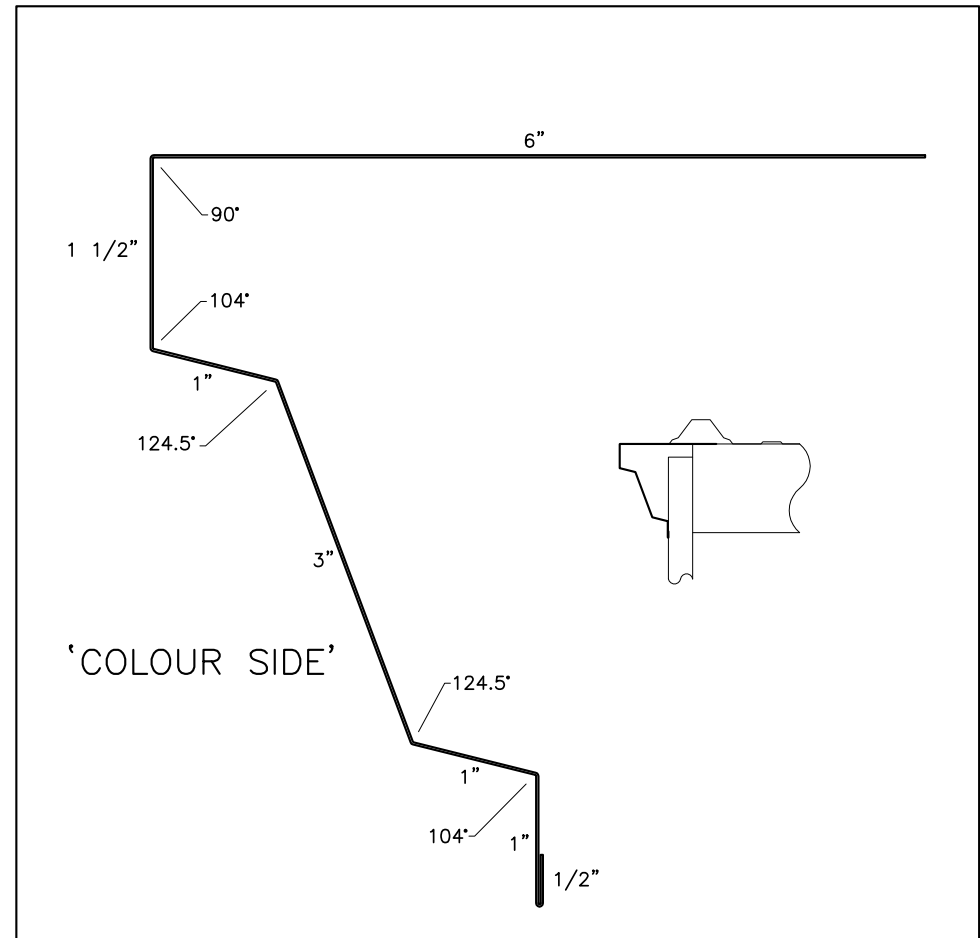

GIRTH: 14"

GAUGE	WEIGHT
29	0.64#/FT.
28	0.81#/FT.
26	0.94#/FT.
24	1.22#/FT.

		7825 Springwater Road Aylmer, Ontario N5H 2R4 519 - 765 - 2244 www.exsteel.com	
		DATE: JAN 30/1990	DRAWN: BVERN
DATE:		CHECKED:	
DATE:		PROG:	
DATE:		ISSUED:	

DESCRIPTION:
 GABLE TRIM (WITH PROFILE)
 - 5/8"-3/4" WALL PANEL

1	GENERAL DETAIL REVIEW	JAN 01/09	BJD
REV	DESCRIPTION	DATE	BY

DRAWING # **M42**

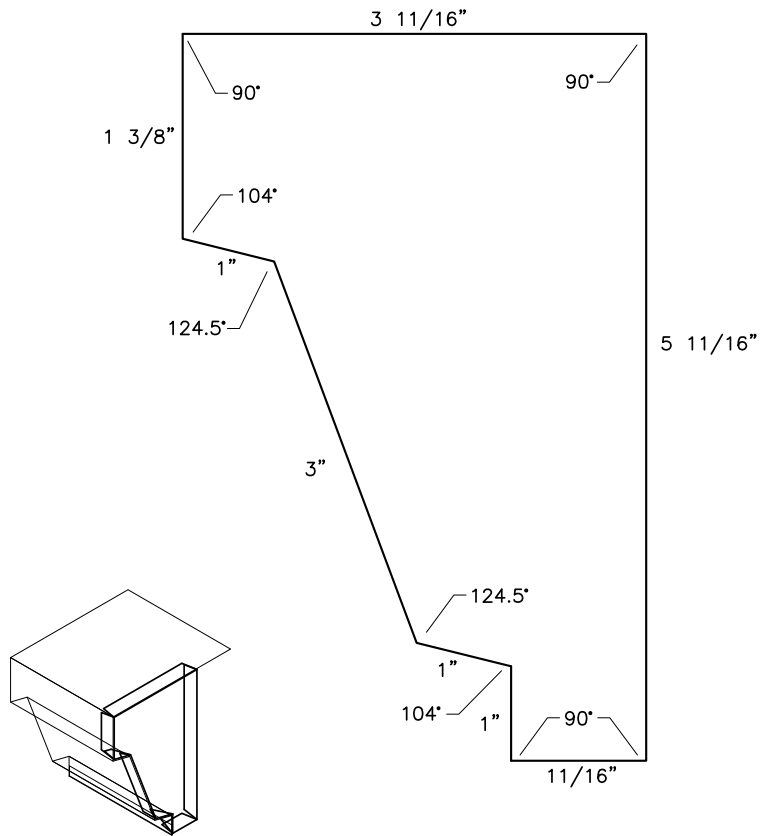

GAUGE	WEIGHT
29	1.88# ea.
28	2.07# ea.
26	2.49# ea.
24	3.32# ea.

		7825 Springwater Road Aylmer, Ontario N5H 2R4 519 - 765 - 2244 www.exsteel.com	
		DATE: DEC 03/2009	DRAWN: AF
DATE:	CHECKED:	DATE:	PROG:
DATE:	ISSUED:	DATE:	ISSUED:
DESCRIPTION: END CAP - GABLE (M42) - EAVE (M41) - RIGHT			
DRAWING #		M73	
1	GENERAL DETAIL REVIEW	JAN 01/09	BJD
REV	DESCRIPTION	DATE	BY

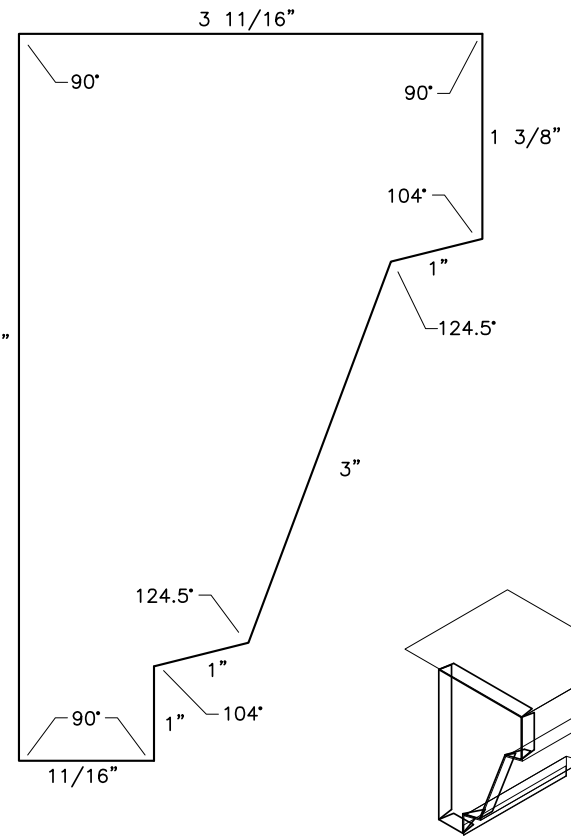

GAUGE	WEIGHT
29	1.88# ea.
28	2.07# ea.
26	2.49# ea.
24	3.32# ea.

		7825 Springwater Road Aylmer, Ontario N5H 2R4 519 - 765 - 2244 www.exsteel.com	
		DATE: DEC 03/2009	DRAWN: AF
DATE:	CHECKED:	DATE:	PROG:
DATE:	ISSUED:	DATE:	ISSUED:
DESCRIPTION: END CAP - GABLE (M42) - EAVE (M41) - LEFT			
DRAWING #		M72	
1	GENERAL DETAIL REVIEW	JAN 01/09	BJD
REV	DESCRIPTION	DATE	BY

'COLOUR SIDE'

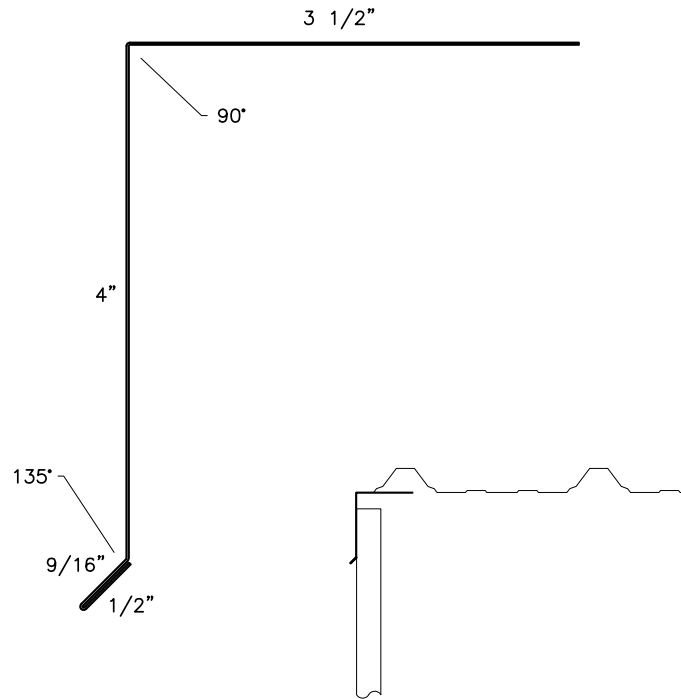

GIRTH: 8 9/16"

GAUGE	WEIGHT
29	0.47#/FT.
28	0.45#/FT.
26	0.54#/FT.
24	0.71#/FT.

exsteel BUILDING COMPONENTS		7825 Springwater Road Aylmer, Ontario N5H 2R4 519 - 765 - 2244 www.exsteel.com	
DATE: JAN 25/1990	DRAWN: BVERN		
DATE:	CHECKED:		
DATE:	PROG:		
DATE:	ISSUED:		
DESCRIPTION: GABLE TRIM (WITHOUT PROFILE) - SCREW DOWN ROOF - UP TO 1 1/2" WALL PANEL			
DRAWING #			M19

REV	DESCRIPTION	DATE	BY
3	DIMENSION/GIRTH REVISED	MAR 15/11	AF
2	EXTRA MATERIAL REMOVED	JAN 06/11	AF
1	GENERAL DETAIL REVIEW	JAN 01/09	BJD

'COLOUR SIDE'

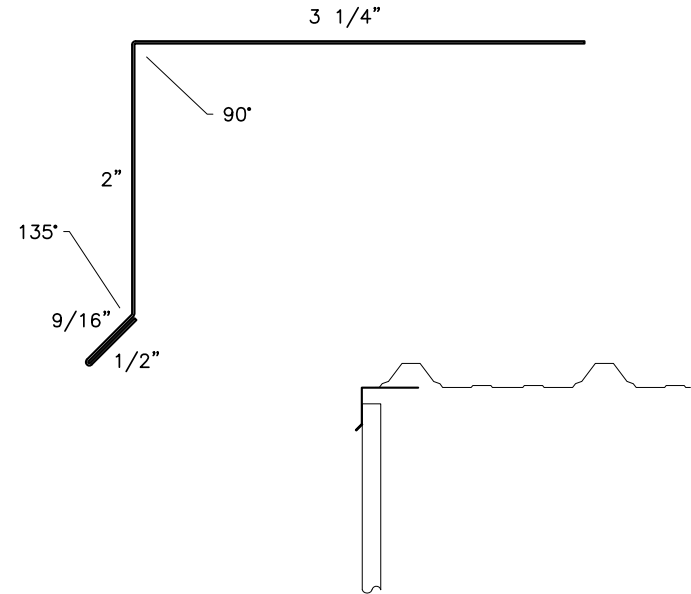

GIRTH: 6 5/16"

GAUGE	WEIGHT
29	0.36#/FT.
28	0.34#/FT.
26	0.41#/FT.
24	0.55#/FT.

exsteel BUILDING COMPONENTS		7825 Springwater Road Aylmer, Ontario N5H 2R4 519 - 765 - 2244 www.exsteel.com	
DATE: JUNE 19/2011	DRAWN: AF		
DATE:	CHECKED:		
DATE:	PROG:		
DATE:	ISSUED:		
DESCRIPTION: GABLE TRIM (WITHOUT PROFILE) - SCREW DOWN ROOF - 5/8"-3/4" PANEL			
DRAWING #			M285

REV	DESCRIPTION	DATE	BY
2	REVISED DIMENSION/GIRTH	SEP 05/11	AF
1	GENERAL DETAIL REVIEW	JUN 19/11	AF

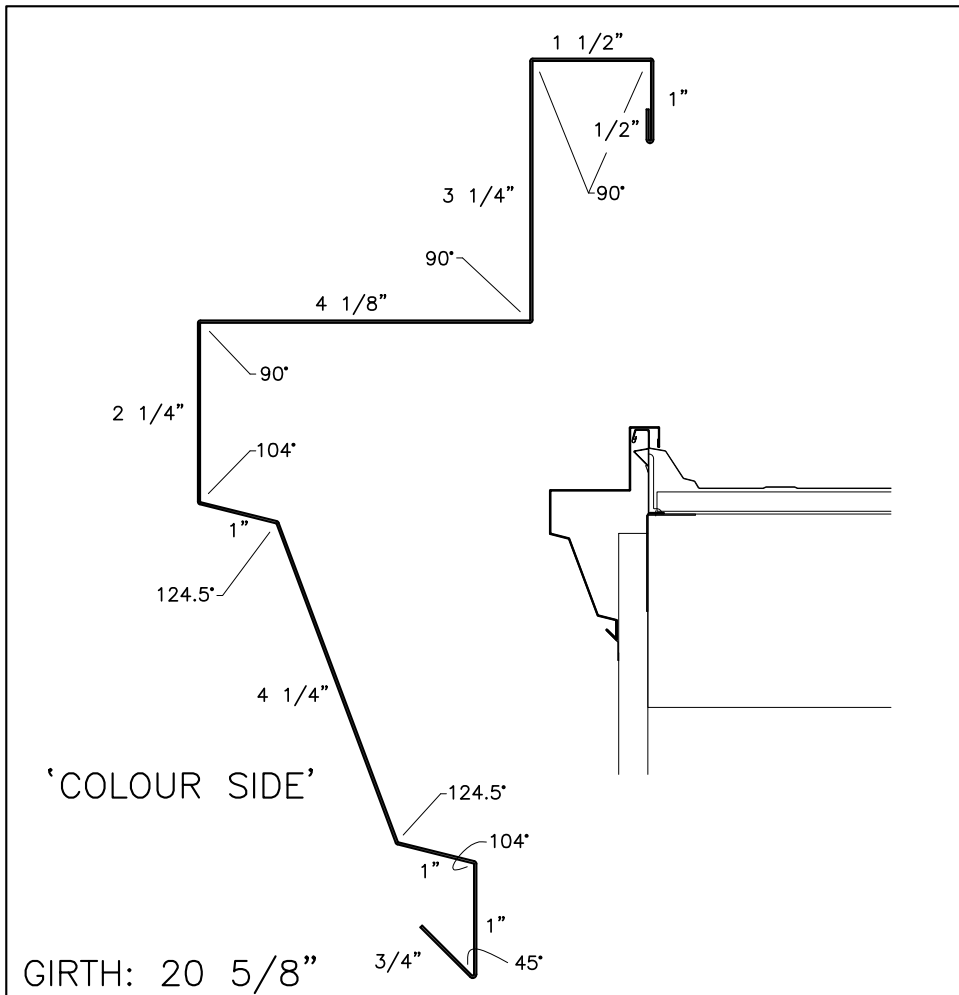

GAUGE	WEIGHT
29	1.05#/FT.
28	1.08#/FT.
26	1.29#/FT.
24	1.72#/FT.

		7825 Springwater Road Aylmer, Ontario N5H 2R4 519 - 765 - 2244 www.exsteel.com	
		DATE: MAR 19/2001	DRAWN: MAG
DATE:		CHECKED:	
DATE:		PROG:	
DATE:		ISSUED:	
DESCRIPTION: GABLE TRIM START (WITH PROFILE) - RTL-24 - FLOATING - 1 1/2" WALL PANEL			
DRAWING #		M120	
1	GENERAL DETAIL REVIEW	JAN 01/09	BJD
REV	DESCRIPTION	DATE	BY

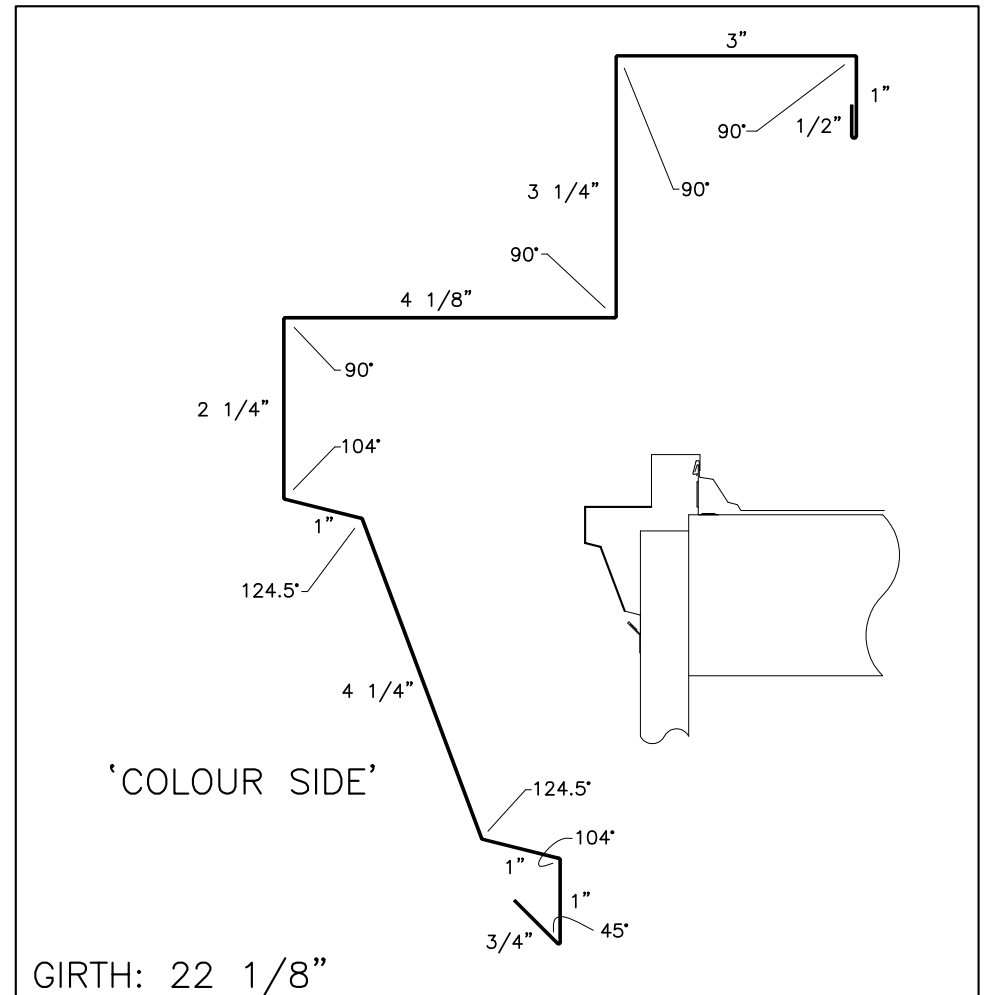

GAUGE	WEIGHT
29	1.04#/FT.
28	1.15#/FT.
26	1.38#/FT.
24	1.84#/FT.

		7825 Springwater Road Aylmer, Ontario N5H 2R4 519 - 765 - 2244 www.exsteel.com	
		DATE: MAR 19/2001	DRAWN: MAG
DATE:		CHECKED:	
DATE:		PROG:	
DATE:		ISSUED:	
DESCRIPTION: GABLE TRIM START (WITH PROFILE) - RTL-24 - FLOATING - 3" WALL PANEL			
DRAWING #		M122	
1	GENERAL DETAIL REVIEW	JAN 01/09	BJD
REV	DESCRIPTION	DATE	BY

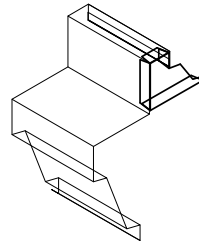
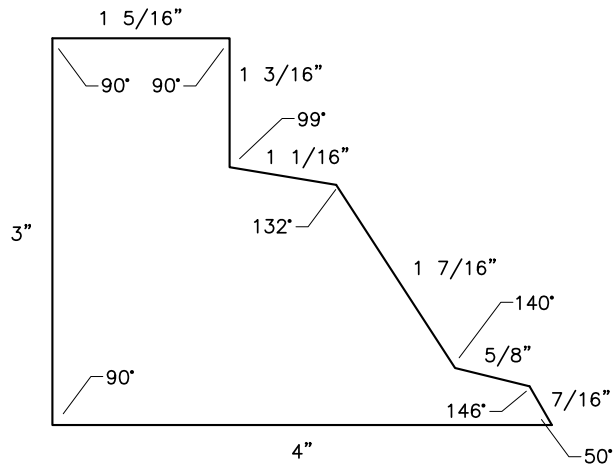

GAUGE	WEIGHT
29	0.19# ea.
28	0.21# ea.
26	0.25# ea.
24	0.33# ea.

		7825 Springwater Road Aylmer, Ontario N5H 2R4 519 - 765 - 2244 www.exsteel.com	
		DATE: DEC 03/2009	DRAWN: AF
DATE:		CHECKED:	
DATE:		PROG:	
DATE:		ISSUED:	
DESCRIPTION:			
END CAP – PANEL VOID CLOSURE (M120) – RIGHT			
DRAWING #		M134	
1	GENERAL DETAIL REVIEW	JAN 01/09	BJD
REV	DESCRIPTION	DATE	BY

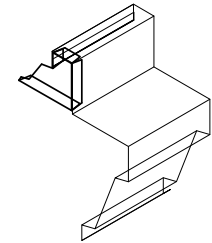
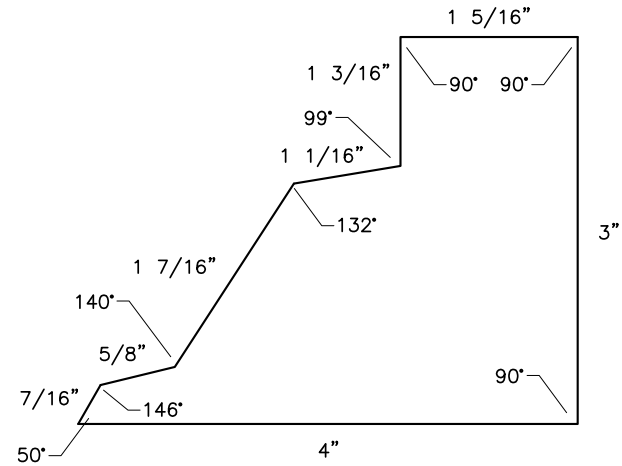

GAUGE	WEIGHT
29	0.19# ea.
28	0.21# ea.
26	0.25# ea.
24	0.33# ea.

		7825 Springwater Road Aylmer, Ontario N5H 2R4 519 - 765 - 2244 www.exsteel.com	
		DATE: DEC 03/2009	DRAWN: AF
DATE:		CHECKED:	
DATE:		PROG:	
DATE:		ISSUED:	
DESCRIPTION:			
END CAP – PANEL VOID CLOSURE (M120) – LEFT			
DRAWING #		M135	
1	GENERAL DETAIL REVIEW	JAN 01/09	BJD
REV	DESCRIPTION	DATE	BY

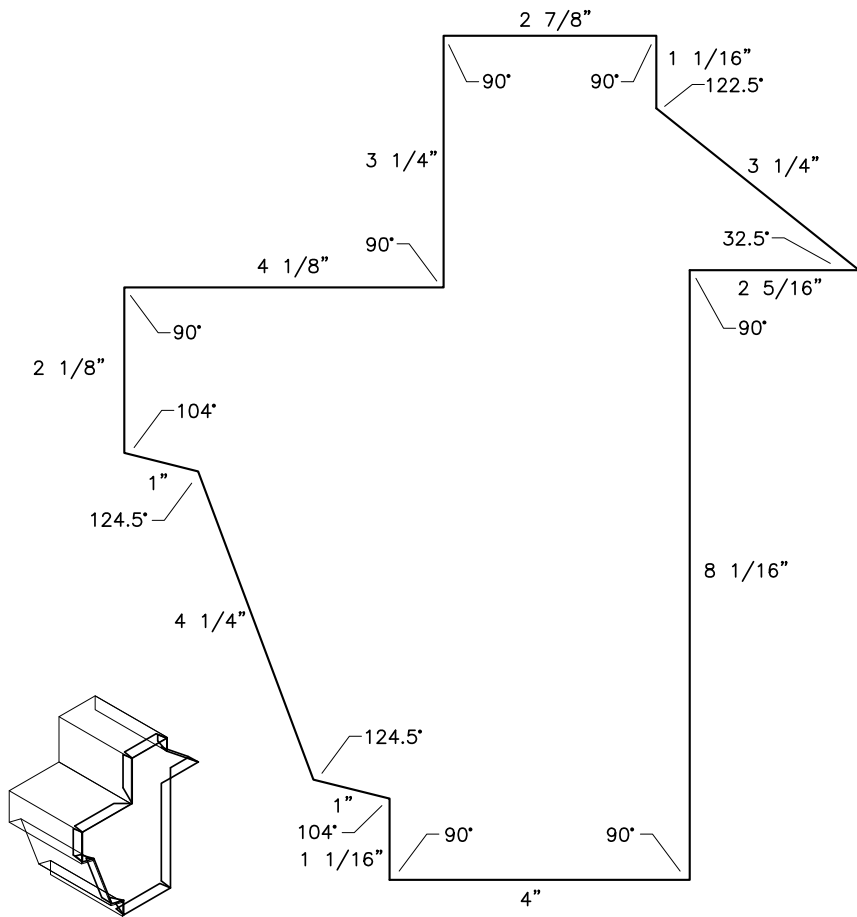

GAUGE	WEIGHT
29	1.88# ea.
28	2.07# ea.
26	2.49# ea.
24	3.32# ea.

		7825 Springwater Road Aylmer, Ontario N5H 2R4 519 - 765 - 2244 www.exsteel.com	
		DATE: JAN 14/2010	DRAWN: LD
DATE:		CHECKED:	
DATE:		PROG:	
DATE:		ISSUED:	
DESCRIPTION:			
END CAP - GABLE (M122) - RIGHT			
DRAWING #		M77	
1	GENERAL DETAIL REVIEW	JAN 01/09	BJD
REV	DESCRIPTION	DATE	BY

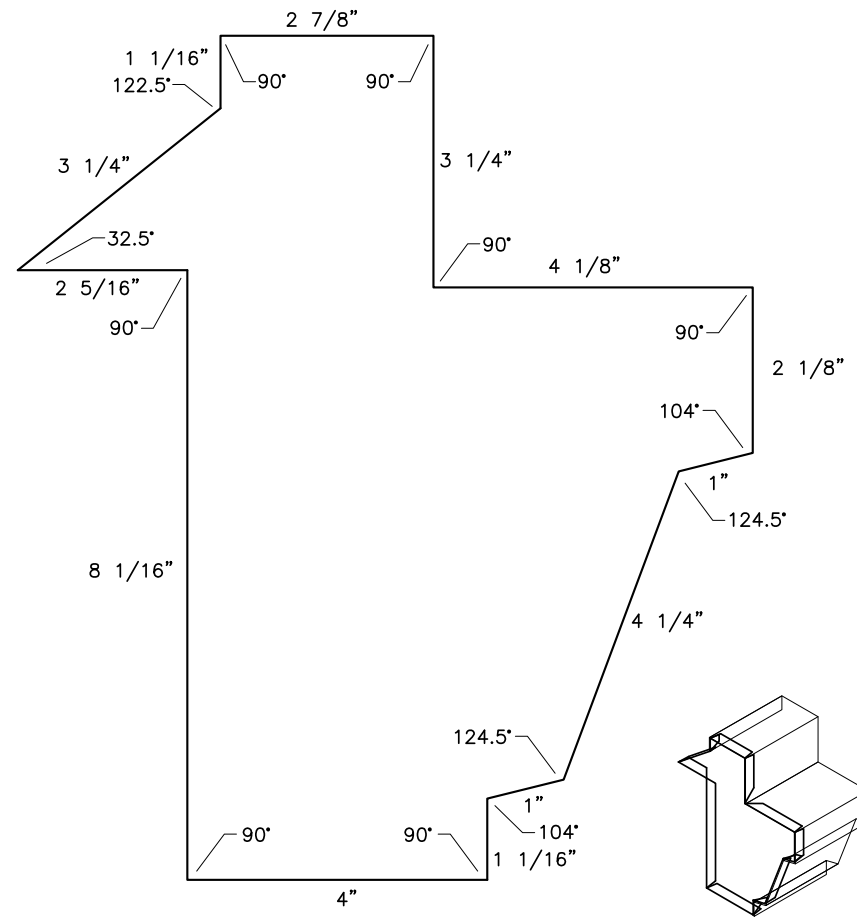

GAUGE	WEIGHT
29	1.88# ea.
28	2.07# ea.
26	2.49# ea.
24	3.32# ea.

		7825 Springwater Road Aylmer, Ontario N5H 2R4 519 - 765 - 2244 www.exsteel.com	
		DATE: JAN 14/2010	DRAWN: LD
DATE:		CHECKED:	
DATE:		PROG:	
DATE:		ISSUED:	
DESCRIPTION:			
END CAP - GABLE (M122) - LEFT			
DRAWING #		M78	
1	GENERAL DETAIL REVIEW	JAN 01/09	BJD
REV	DESCRIPTION	DATE	BY

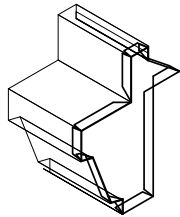
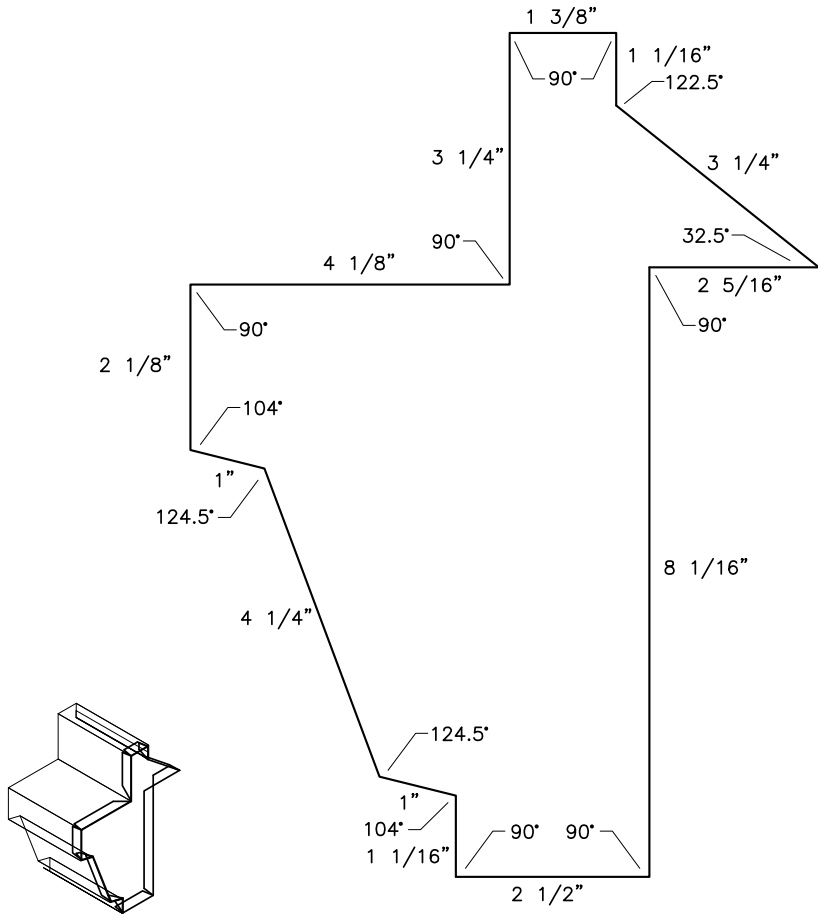

GAUGE	WEIGHT
29	1.88# ea.
28	2.07# ea.
26	2.49# ea.
24	3.32# ea.

		7825 Springwater Road Aylmer, Ontario N5H 2R4 519 - 765 - 2244 www.exsteel.com	
		DATE: DEC 03/2009	DRAWN: AF
DATE:		CHECKED:	
DATE:		PROG:	
DATE:		ISSUED:	
DESCRIPTION:			
END CAP - GABLE (M120) - RIGHT			
DRAWING #		M57	
1	GENERAL DETAIL REVIEW	JAN 01/09	BJD
REV	DESCRIPTION	DATE	BY

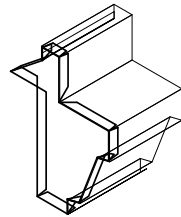
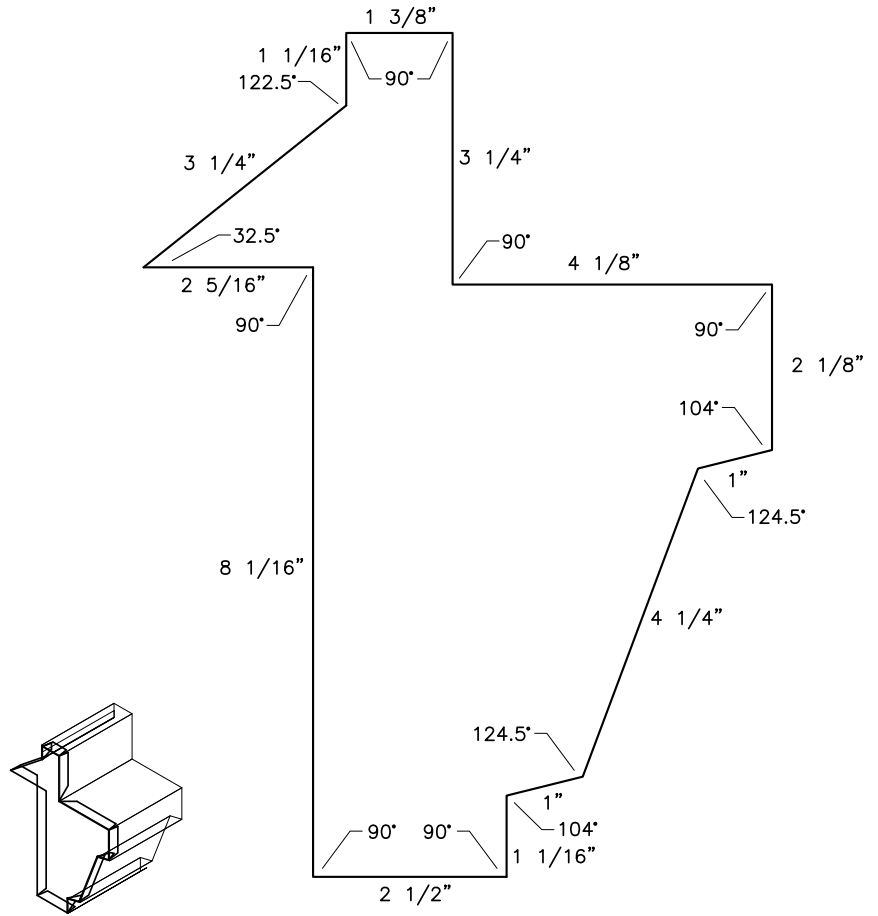

GAUGE	WEIGHT
29	1.88# ea.
28	2.07# ea.
26	2.49# ea.
24	3.32# ea.

		7825 Springwater Road Aylmer, Ontario N5H 2R4 519 - 765 - 2244 www.exsteel.com	
		DATE: DEC 03/2009	DRAWN: AF
DATE:		CHECKED:	
DATE:		PROG:	
DATE:		ISSUED:	
DESCRIPTION:			
END CAP - GABLE (M120) - LEFT			
DRAWING #		M58	
1	GENERAL DETAIL REVIEW	JAN 01/09	BJD
REV	DESCRIPTION	DATE	BY

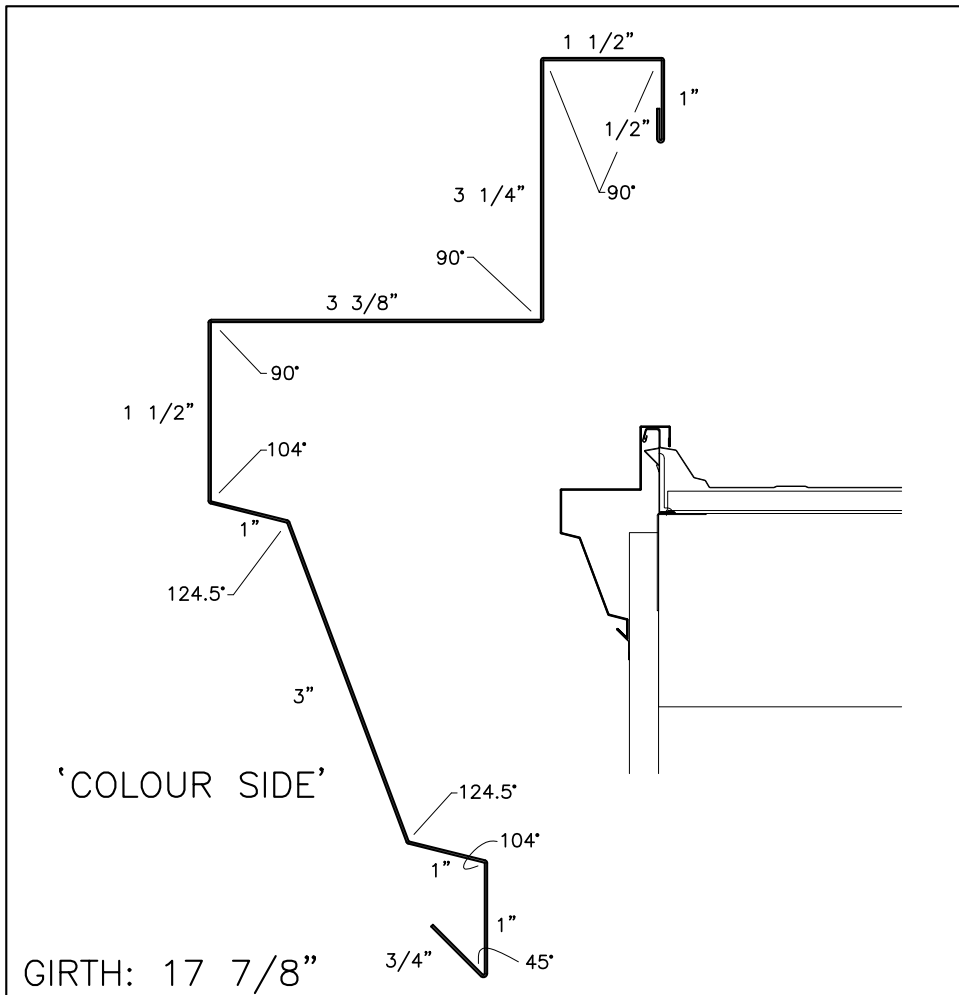

GIRTH: 17 7/8"

GAUGE	WEIGHT
29	0.84#/FT.
28	0.94#/FT.
26	1.12#/FT.
24	1.49#/FT.

 BUILDING COMPONENTS	7825 Springwater Road Aylmer, Ontario N5H 2R4 519 - 765 - 2244 www.exsteel.com	
	DATE: MAR 28/2006	DRAWN: SB
	DATE:	CHECKED:
	DATE:	PROG:
DATE:	ISSUED:	
DESCRIPTION: GABLE TRIM START (WITH PROFILE) - RTL-24 - FLOATING - 5/8"-3/4" WALL PANEL		
DRAWING #	M153	

REV	DESCRIPTION	DATE	BY
1	GENERAL DETAIL REVIEW	JAN 01/09	BJD

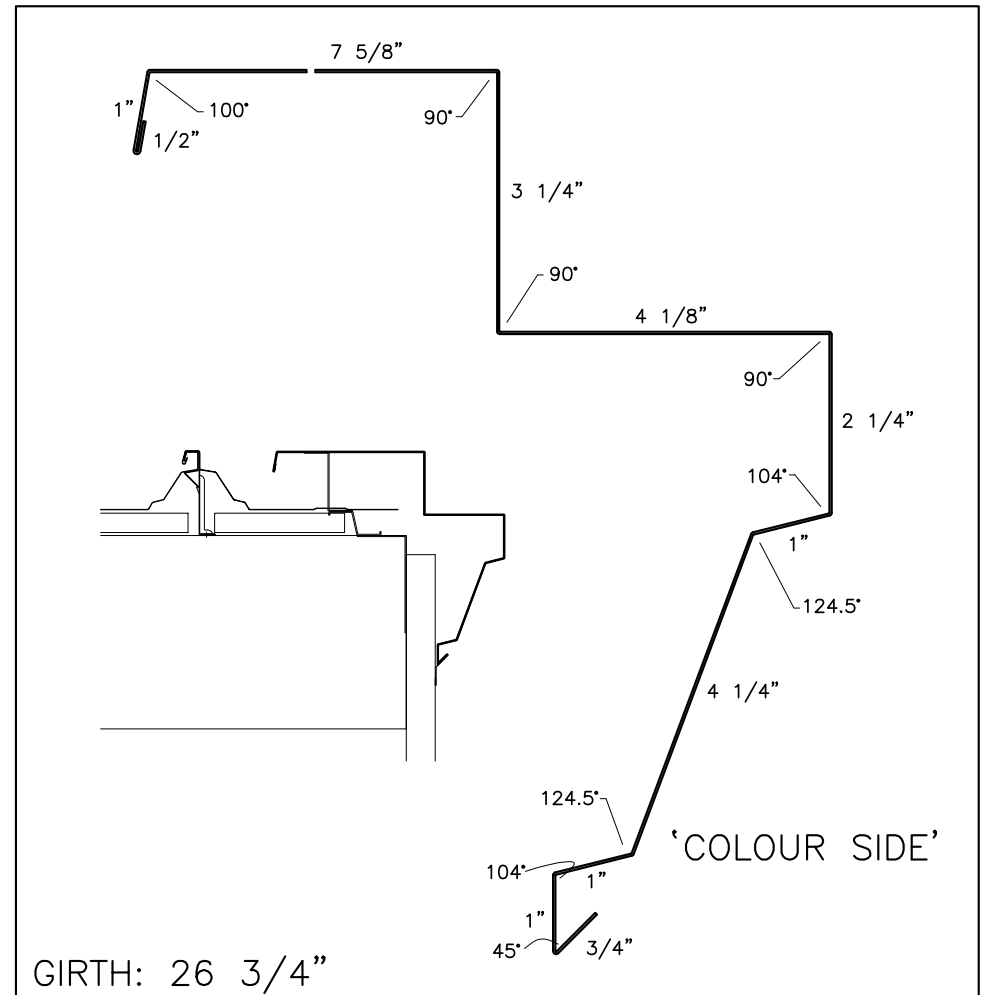

GIRTH: 26 3/4"

GAUGE	WEIGHT
29	1.36#/FT.
28	1.40#/FT.
26	1.67#/FT.
24	2.23#/FT.

 BUILDING COMPONENTS	7825 Springwater Road Aylmer, Ontario N5H 2R4 519 - 765 - 2244 www.exsteel.com	
	DATE: MAR 19/2001	DRAWN: MAG
	DATE:	CHECKED:
	DATE:	PROG:
DATE:	ISSUED:	
DESCRIPTION: GABLE TRIM TERMINATION (WITH PROFILE) - RTL-24 - FLOATING - 1 1/2" WALL PANEL		
DRAWING #	M121	

REV	DESCRIPTION	DATE	BY
1	GENERAL DETAIL REVIEW	JAN 01/09	BJD

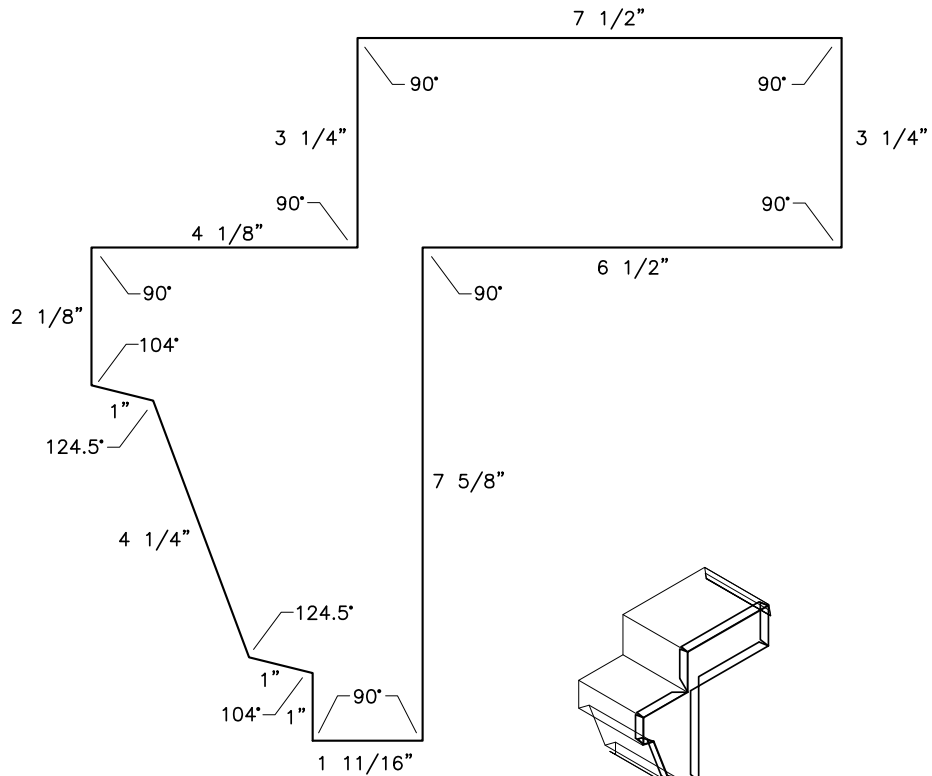

GAUGE	WEIGHT
29	1.88# ea.
28	2.07# ea.
26	2.49# ea.
24	3.32# ea.

		7825 Springwater Road Aylmer, Ontario N5H 2R4 519 - 765 - 2244 www.exsteel.com	
		DATE: DEC 03/2009	DRAWN: AF
DATE:		CHECKED:	
DATE:		PROG:	
DATE:		ISSUED:	
DESCRIPTION:			
END CAP - GABLE (M121) - RIGHT			
DRAWING #		M59	
1	GENERAL DETAIL REVIEW	JAN 01/09	BJD
REV	DESCRIPTION	DATE	BY

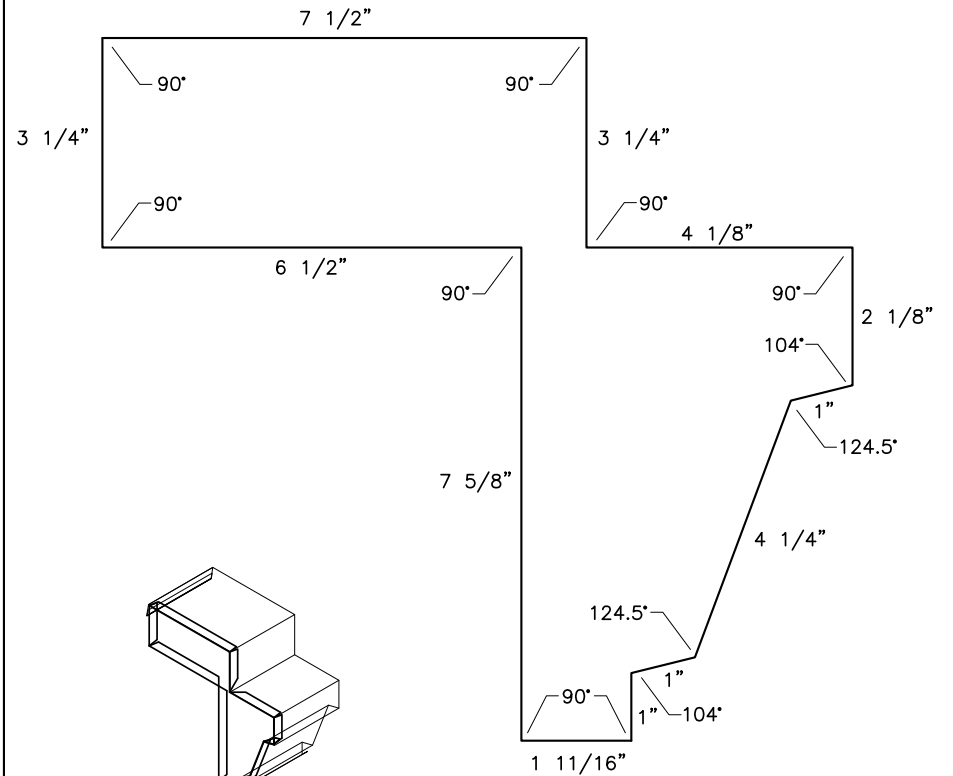

GAUGE	WEIGHT
29	1.88# ea.
28	2.07# ea.
26	2.49# ea.
24	3.32# ea.

		7825 Springwater Road Aylmer, Ontario N5H 2R4 519 - 765 - 2244 www.exsteel.com	
		DATE: DEC 03/2009	DRAWN: AF
DATE:		CHECKED:	
DATE:		PROG:	
DATE:		ISSUED:	
DESCRIPTION:			
END CAP - GABLE (M121) - LEFT			
DRAWING #		M60	
1	GENERAL DETAIL REVIEW	JAN 01/09	BJD
REV	DESCRIPTION	DATE	BY

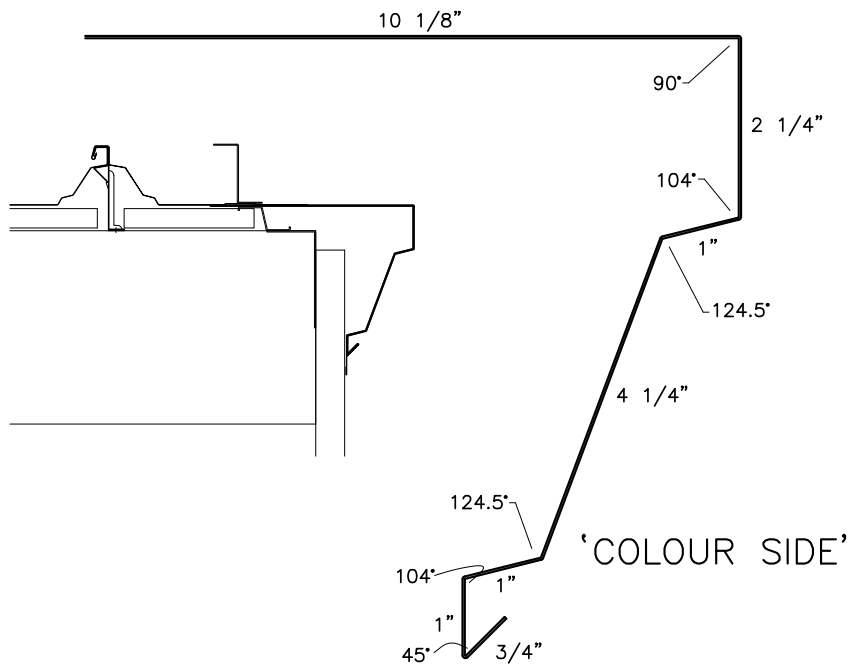

GIRTH: 20 3/8"

GAUGE	WEIGHT
29	0.95#/FT.
28	1.06#/FT.
26	1.27#/FT.
24	1.70#/FT.

		7825 Springwater Road Aylmer, Ontario N5H 2R4 519 - 765 - 2244 www.exsteel.com	
		DATE: MAR 19/2001	DRAWN: MAG
DATE:		CHECKED:	
DATE:		PROG:	
DATE:		ISSUED:	
DESCRIPTION: GABLE TRIM TERMINATION (WITH PROFILE) - RTL-24 - FLOATING - 1 1/2" WALL PANEL			
DRAWING #		M123	

REV	DESCRIPTION	DATE	BY
1	GENERAL DETAIL REVIEW	JAN 01/09	BJD

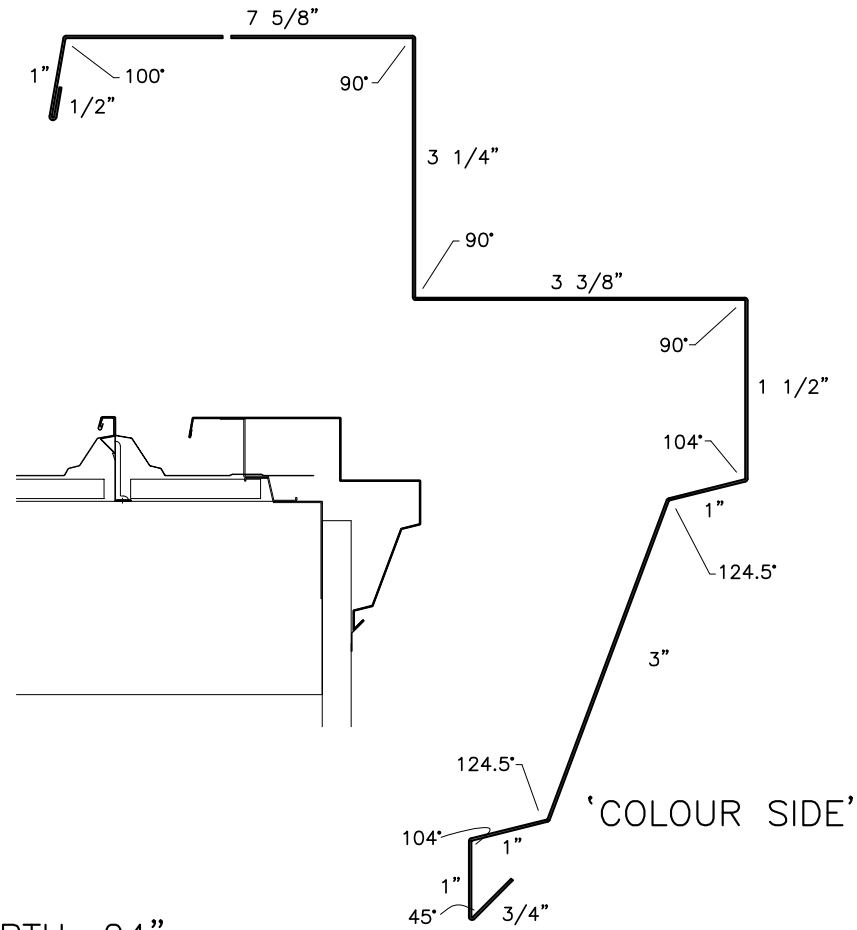

GIRTH: 24"

GAUGE	WEIGHT
29	1.13#/FT.
28	1.26#/FT.
26	1.50#/FT.
24	2.00#/FT.

		7825 Springwater Road Aylmer, Ontario N5H 2R4 519 - 765 - 2244 www.exsteel.com	
		DATE: MAR 28/2006	DRAWN: SB
DATE:		CHECKED:	
DATE:		PROG:	
DATE:		ISSUED:	
DESCRIPTION: GABLE TRIM TERMINATION (WITH PROFILE) - RTL-24 - FLOATING - 5/8"-3/4" WALL PANEL			
DRAWING #		M154	

REV	DESCRIPTION	DATE	BY
1	GENERAL DETAIL REVIEW	JAN 01/09	BJD

'COLOUR SIDE'

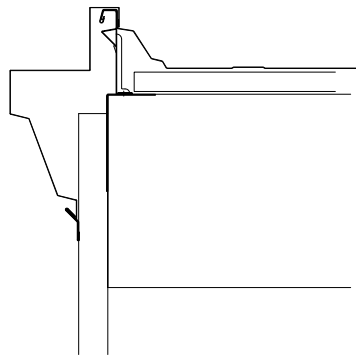
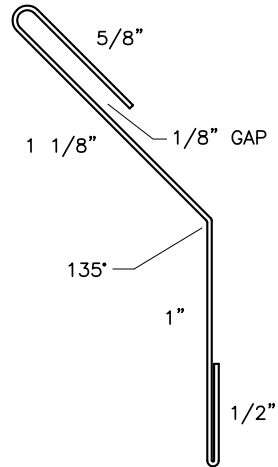

GIRTH: 3 1/4"

GAUGE	WEIGHT
29	0.16#/FT.
28	0.17#/FT.
26	0.20#/FT.
24	0.27#/FT.

exsteel BUILDING COMPONENTS		7825 Springwater Road Aylmer, Ontario N5H 2R4 519 - 765 - 2244 www.exsteel.com	
DATE:	MAR 19/2001	DRAWN:	MAG
DATE:		CHECKED:	
DATE:		PROG:	
DATE:		ISSUED:	
DESCRIPTION: GABLE TRIM CLIP - RTL-24 - FLOATING			
DRAWING #		M119	
REV	DESCRIPTION	DATE	BY
1	GENERAL DETAIL REVIEW	JAN 01/09	BJD

'COLOUR SIDE'

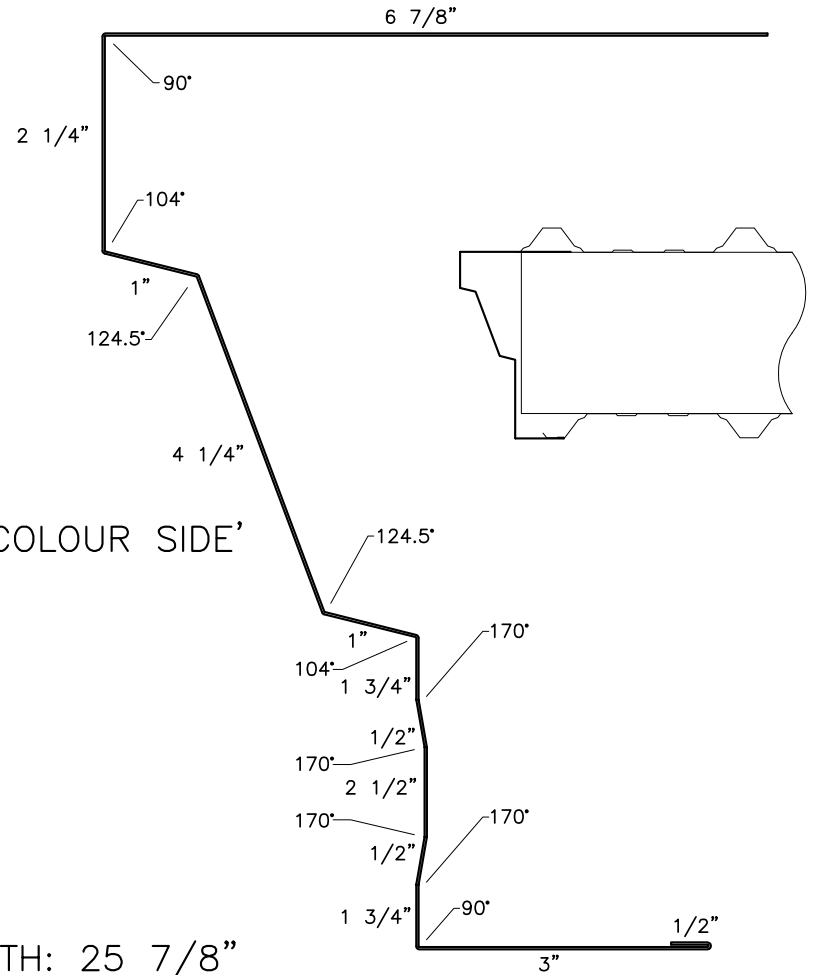

GIRTH: 25 7/8"

GAUGE	WEIGHT
29	1.21#/FT.
28	1.35#/FT.
26	1.62#/FT.
24	2.16#/FT.

exsteel BUILDING COMPONENTS		7825 Springwater Road Aylmer, Ontario N5H 2R4 519 - 765 - 2244 www.exsteel.com	
DATE:	MAY 14/2009	DRAWN:	LD
DATE:		CHECKED:	
DATE:		PROG:	
DATE:		ISSUED:	
DESCRIPTION: GABLE OVERHANG TRIM (WITH PROFILE) - 12" PURLIN - 1 1/2" SOFFIT PANEL			
DRAWING #		M231	
REV	DESCRIPTION	DATE	BY

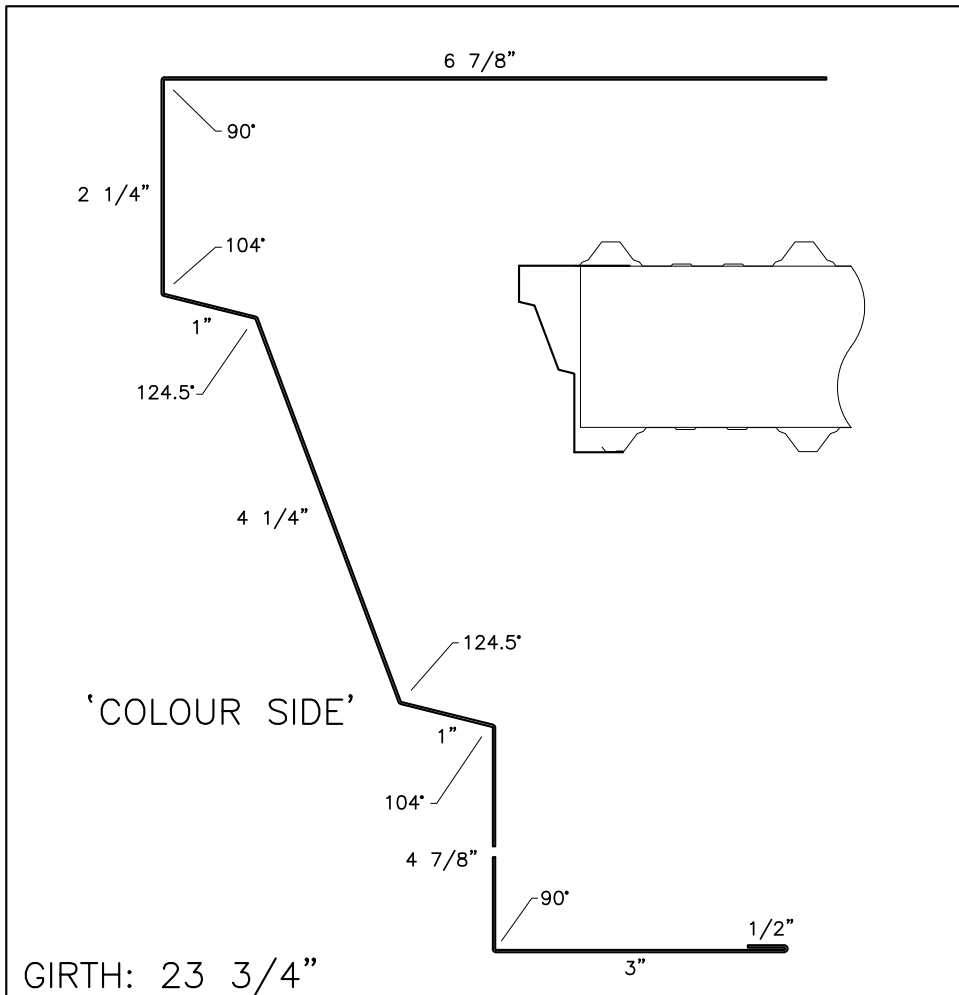

GIRTH: 23 3/4"

GAUGE	WEIGHT
29	1.11#/FT.
28	1.38#/FT.
26	1.61#/FT.
24	2.07#/FT.

exsteel BUILDING COMPONENTS	7825 Springwater Road Aylmer, Ontario N5H 2R4 519 - 765 - 2244 www.exsteel.com	
	DATE: JAN 29/1990	DRAWN: BVERN
	DATE:	CHECKED:
	DATE:	PROG:
DATE:	ISSUED:	
DESCRIPTION: GABLE OVERHANG TRIM (WITH PROFILE) - SCREW DOWN ROOF - 10" PURLIN - 1 1/2" SOFFIT PANEL		
DRAWING #		M32

REV	DESCRIPTION	DATE	BY
1	GENERAL DETAIL REVIEW	JAN 01/09	BJD

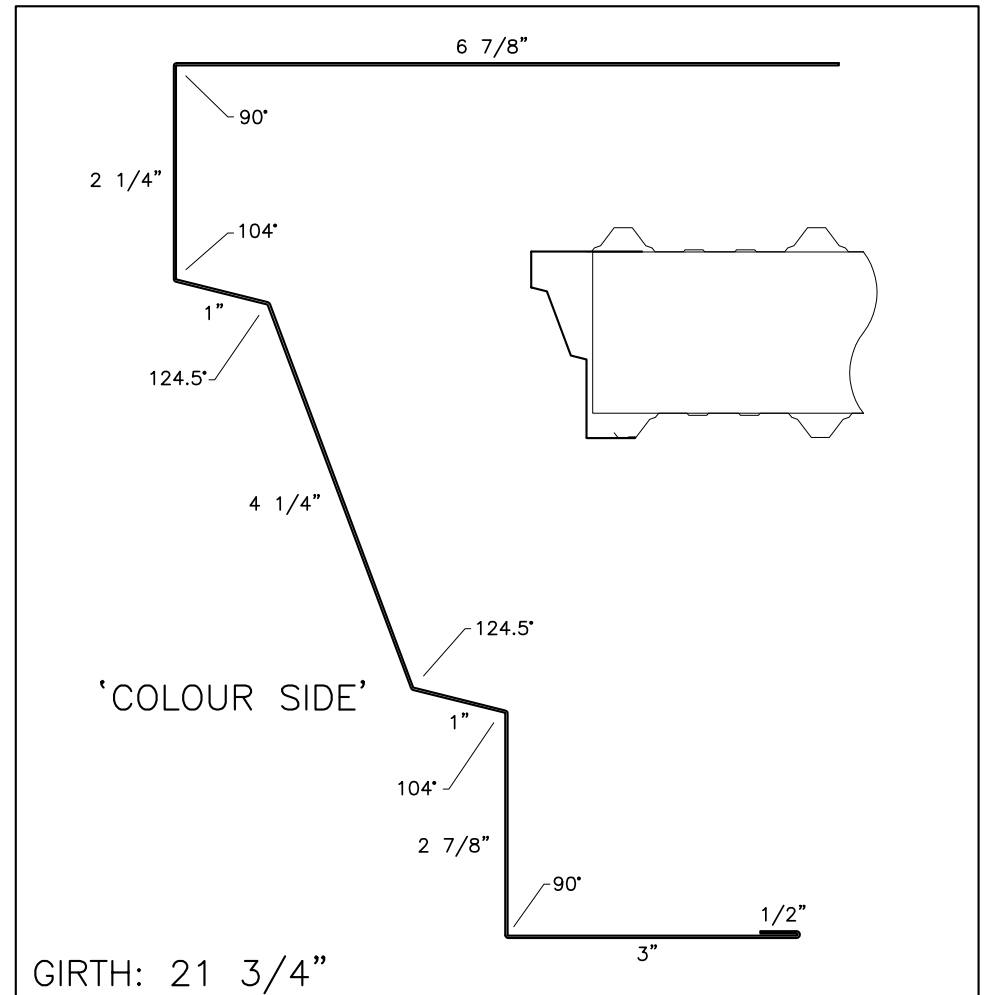

GIRTH: 21 3/4"

GAUGE	WEIGHT
29	1.02#/FT.
28	1.13#/FT.
26	1.36#/FT.
24	1.81#/FT.

exsteel BUILDING COMPONENTS	7825 Springwater Road Aylmer, Ontario N5H 2R4 519 - 765 - 2244 www.exsteel.com	
	DATE: MAY 14/2009	DRAWN: LD
	DATE:	CHECKED:
	DATE:	PROG:
DATE:	ISSUED:	
DESCRIPTION: GABLE OVERHANG TRIM (WITH PROFILE) - 8" PURLIN - 1 1/2" SOFFIT PANEL		
DRAWING #		M230

REV	DESCRIPTION	DATE	BY

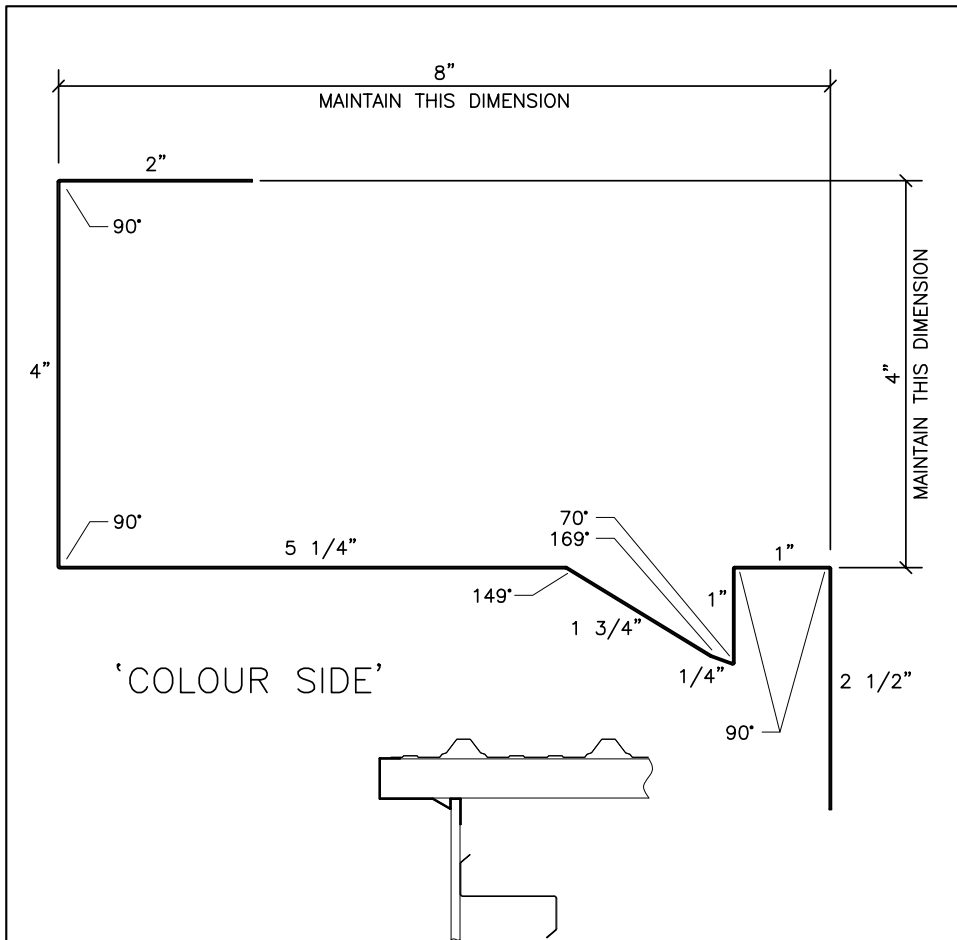

GIRTH: 17 3/4"

GAUGE	WEIGHT
29	0.72#/FT.
28	0.90#/FT.
26	1.08#/FT.
24	1.44#/FT.

		7825 Springwater Road Aylmer, Ontario N5H 2R4 519 - 765 - 2244 www.exsteel.com	
		DATE: JAN 27/2010	DRAWN: AF
DATE:		CHECKED:	
DATE:		PROG:	
DATE:		ISSUED:	
DESCRIPTION: GABLE - 8" SOFFIT/4" FASCIA TRIM - SCREW DOWN ROOF - 5/8" - 3/4" PANEL			
DRAWING #		M237	
REV	DESCRIPTION	DATE	BY

5	REVISED DIMENSIONS/ANGLES	SEP 05/11	AF
4	REVISED DESC./NOTE ADDED	JAN 12/11	AF
3	GENERAL REVISION	DEC 13/10	AF
2	DIMENSION AND GIRTH REVISED	DEC 02/10	LD
1	GENERAL DETAIL REVIEW	JAN 27/10	LD

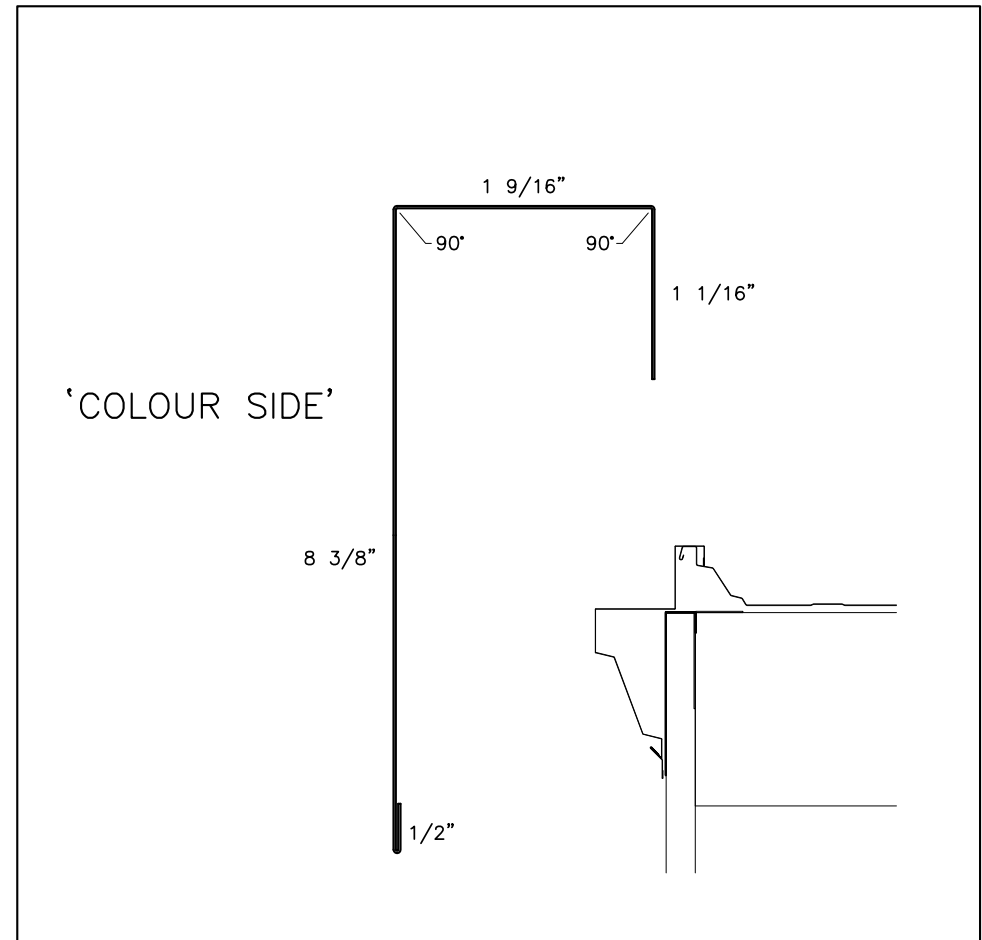

GIRTH: 11 1/2"

GAUGE	WEIGHT
29	0.54#/FT.
28	0.60#/FT.
26	0.72#/FT.
24	0.96#/FT.

		7825 Springwater Road Aylmer, Ontario N5H 2R4 519 - 765 - 2244 www.exsteel.com	
		DATE: MAR 19/2001	DRAWN: MAG
DATE:		CHECKED:	
DATE:		PROG:	
DATE:		ISSUED:	
DESCRIPTION: WALL CAP - GABLE (M120/M121/M123) - 1 1/2" WALL PANEL			
DRAWING #		M125	
REV	DESCRIPTION	DATE	BY

1	GENERAL DETAIL REVIEW	JAN 01/09	BJD
---	-----------------------	-----------	-----

'COLOUR SIDE'

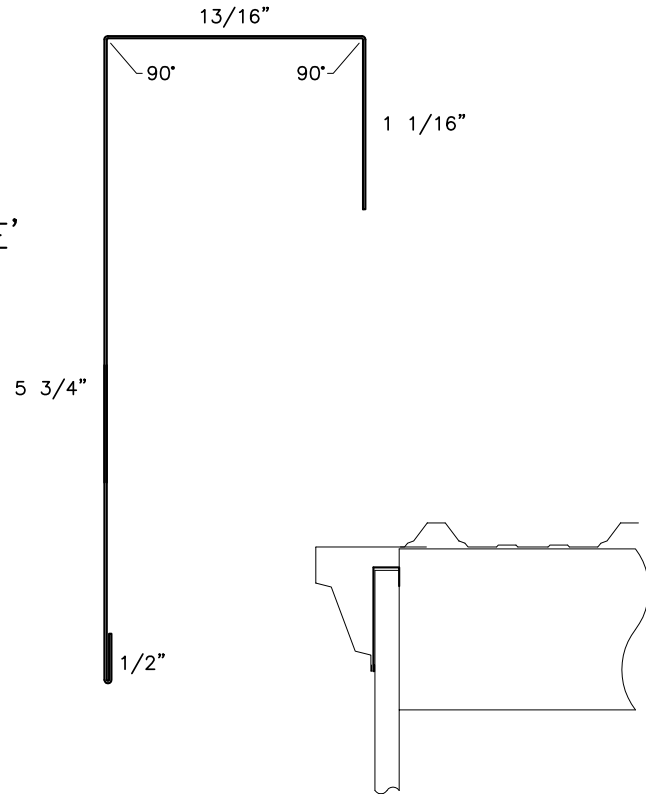

GIRTH: 8 1/8"

GAUGE	WEIGHT
29	0.38#/FT.
28	0.42#/FT.
26	0.50#/FT.
24	0.67#/FT.

		7825 Springwater Road Aylmer, Ontario N5H 2R4 519 - 765 - 2244 www.exsteel.com	
		DATE: MAR 28/2006	DRAWN: SB
DATE:		CHECKED:	
DATE:		PROG:	
DATE:		ISSUED:	
DESCRIPTION: WALL CAP - GABLE (M03) - 5/8"-3/4" WALL PANEL			
DRAWING #		M149	
1	GENERAL DETAIL REVIEW	JAN 01/09	BJD
REV	DESCRIPTION	DATE	BY

'COLOUR SIDE'

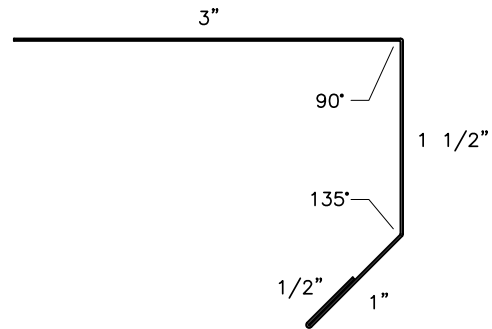

GIRTH: 6"

GAUGE	WEIGHT
29	0.28#/FT.
28	0.30#/FT.
26	0.37#/FT.
24	0.49#/FT.

		7825 Springwater Road Aylmer, Ontario N5H 2R4 519 - 765 - 2244 www.exsteel.com	
		DATE: MAR 24/2010	DRAWN: AF
DATE:		CHECKED:	
DATE:		PROG:	
DATE:		ISSUED:	
DESCRIPTION: RE-ROOF EDGE TRIM			
DRAWING #		M245	
1	GENERAL DETAIL REVIEW	MAR 24/10	LD
REV	DESCRIPTION	DATE	BY

PITCH	DESIG.	A°	B"
.25/12	P02	177.6°	5 15/16"
.5/12	P05	175.2°	5 7/8"
1/12	P10	170.5°	5 13/16"
1.5/12	P15	165.7°	5 3/4"
2/12	P20	161.1°	5 11/16"
3/12	P30	151.9°	5 9/16"
4/12	P40	143.1°	5 7/16"
5/12	P50	134.8°	5 5/16"
6/12	P60	126.9°	5 3/16"
7/12	P70	119.5°	5 1/8"

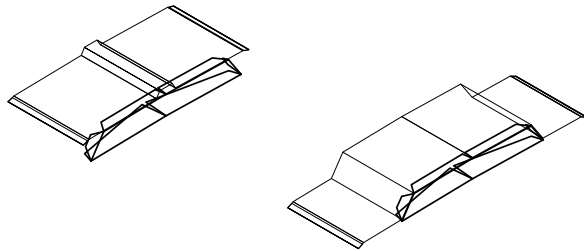
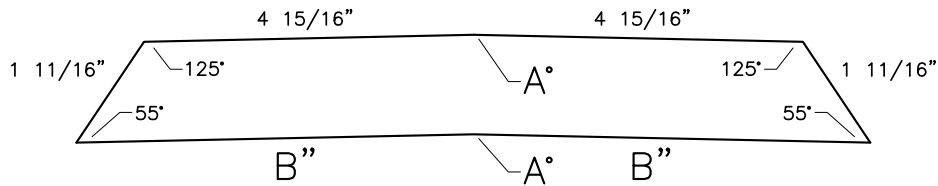

GAUGE	WEIGHT
29	2.75# ea.
28	3.04# ea.
26	3.65# ea.
24	4.87# ea.

exsteel BUILDING COMPONENTS	7825 Springwater Road Aylmer, Ontario N5H 2R4 519 - 765 - 2244 www.exsteel.com	
	DATE: DEC 03/2009	DRAWN: AF
	DATE:	CHECKED:
	DATE:	PROG:
	DATE:	ISSUED:
DESCRIPTION: END CAP - RIDGE CAP (M01/M28)		
DRAWING # M75		

REV	DESCRIPTION	DATE	BY
1	GENERAL DETAIL REVIEW	JAN 01/09	BJD

PITCH	DESIG.	A°
.25/12	P02	92°
.5/12	P05	93°
1/12	P10	95°
2/12	P20	100°
3/12	P30	104°
4/12	P40	109°

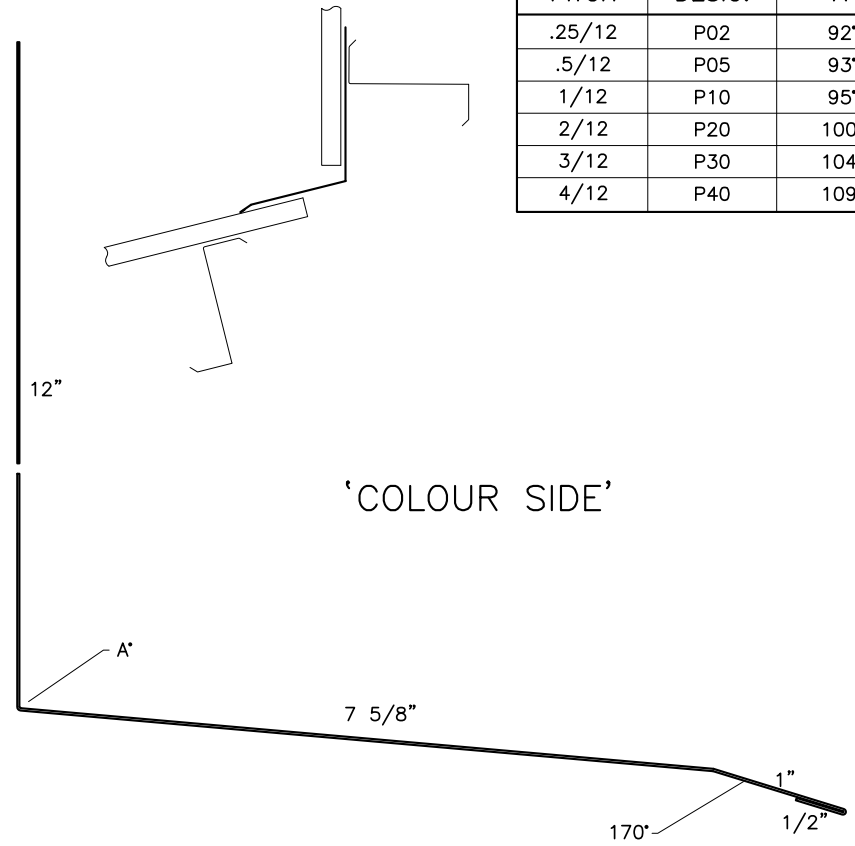

GIRTH: 21 1/8"

GAUGE	WEIGHT
29	1.07#/FT.
28	1.23#/FT.
26	1.43#/FT.
24	1.84#/FT.

exsteel BUILDING COMPONENTS	7825 Springwater Road Aylmer, Ontario N5H 2R4 519 - 765 - 2244 www.exsteel.com	
	DATE: NOV 26/1997	DRAWN: BJD
	DATE:	CHECKED:
	DATE:	PROG:
	DATE:	ISSUED:
DESCRIPTION: HIGH/LOW EAVE FLASHING		
DRAWING # M101		

REV	DESCRIPTION	DATE	BY
1	GENERAL DETAIL REVIEW	JAN 01/09	BJD

PITCH	DESIG.	A°
.25/12	P02	121.5°
.5/12	P05	122.5°
1/12	P10	124.75°
2/12	P20	129.5°
3/12	P30	134°
4/12	P40	138.5°

'COLOUR SIDE'

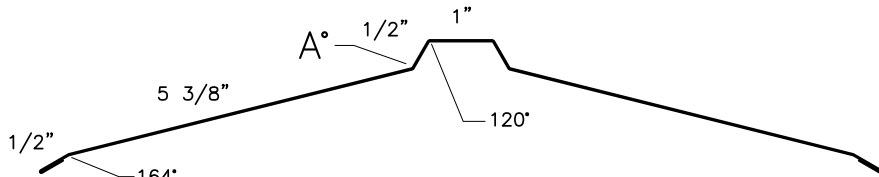

NOTE: TRIM IS SYMMETRICAL ABOUT CENTER LINE.

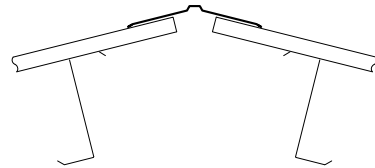

GIRTH: 14 1/2"

GAUGE	WEIGHT
29	0.75#/FT.
28	0.85#/FT.
26	0.99#/FT.
24	1.27#/FT.

exsteel
BUILDING COMPONENTS

7825 Springwater Road
Aylmer, Ontario N5H 2R4
519 - 765 - 2244
www.exsteel.com

DATE: JAN 23/1990 DRAWN: BVERN

DATE: CHECKED:

DATE: PROG:

DATE: ISSUED:

DESCRIPTION:
RIDGE CAP - SCREW DOWN ROOF

REV	DESCRIPTION	DATE	BY
1	GENERAL DETAIL REVIEW	JAN 01/09	BJD

DRAWING # M01

PITCH	DESIG.	A°
.25/12	P02	178°
.5/12	P05	175°
1/12	P10	170°
2/12	P20	161°
3/12	P30	152°
4/12	P40	143°
5/12	P50	135°
6/12	P60	127°

'COLOUR SIDE'

NOTE: TRIM IS SYMMETRICAL ABOUT C

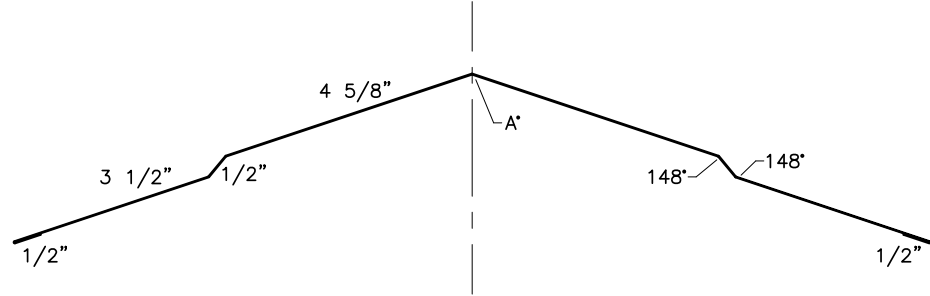

GIRTH: 18 1/4"

GAUGE	WEIGHT
29	0.99#/FT.
28	0.96#/FT.
26	1.15#/FT.
24	1.53#/FT.

exsteel
BUILDING COMPONENTS

7825 Springwater Road
Aylmer, Ontario N5H 2R4
519 - 765 - 2244
www.exsteel.com

DATE: MAR 14/2011 DRAWN: AF

DATE: CHECKED:

DATE: PROG:

DATE: ISSUED:

DESCRIPTION:
RIDGE CAP - SCREW DOWN ROOF

REV	DESCRIPTION	DATE	BY
2	REVISED DIMENSIONS	SEP 05/11	AF
1	GENERAL DETAIL REVIEW	MAR 14/11	AF

DRAWING # M282

PITCH	DESIG.	A°
.25/12	P02	178°
.5/12	P05	175°
1/12	P10	170°
2/12	P20	161°
3/12	P30	152°
4/12	P40	143°
5/12	P50	135°
6/12	P60	127°

'COLOUR SIDE'

NOTE: TRIM IS SYMMETRICAL ABOUT ϕ

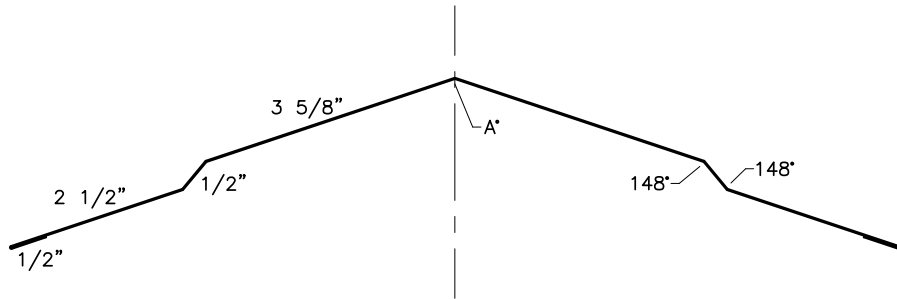

GIRTH: 14 1/4"

GAUGE	WEIGHT
29	0.78#/FT.
28	0.75#/FT.
26	0.90#/FT.
24	1.19#/FT.

 BUILDING COMPONENTS	7825 Springwater Road Aylmer, Ontario N5H 2R4 519 - 765 - 2244 www.exsteel.com	
	DATE: JAN 18/2011	DRAWN: AF
	DATE:	CHECKED:
	DATE:	PROG:
DATE:	ISSUED:	

DESCRIPTION:
RIDGE CAP - SCREW DOWN ROOF

REV	DESCRIPTION	DATE	BY
1	GENERAL DETAIL REVIEW	MAR 14/11	AF

DRAWING # **M263**

PITCH	DESIG.	A°
.25/12	P02	178°
.5/12	P05	175°
1/12	P10	170°
2/12	P20	161°
3/12	P30	152°
4/12	P40	143°
5/12	P50	135°
6/12	P60	127°
7/12	P70	119°
7.5/12	P75	116°

'COLOUR SIDE'

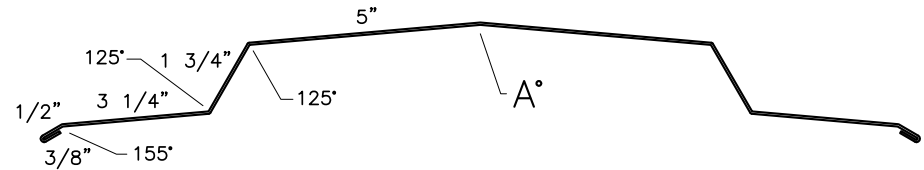

NOTE: TRIM IS SYMMETRICAL ABOUT CENTER LINE.

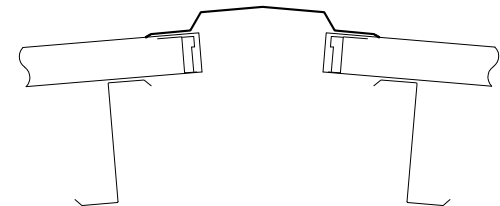

GIRTH: 21 3/4"

GAUGE	WEIGHT
29	1.12#/FT.
28	1.27#/FT.
26	1.48#/FT.
24	1.91#/FT.

 BUILDING COMPONENTS	7825 Springwater Road Aylmer, Ontario N5H 2R4 519 - 765 - 2244 www.exsteel.com	
	DATE: JAN 26/1990	DRAWN: BVERN
	DATE:	CHECKED:
	DATE:	PROG:
DATE:	ISSUED:	

DESCRIPTION:
RIDGE CAP - RTL-24

REV	DESCRIPTION	DATE	BY
1	GENERAL DETAIL REVIEW	JAN 01/09	BJD

DRAWING # **M28**

	PITCH	DESIG.	GIRTH	A°	B"	C"
M255	.25/12	P02	26 1/2"	91°	5/8"	15/16"
	.5/12	P05	26 1/2"	92°	5/8"	15/16"
	1/12	P10	26 1/2"	95°	5/8"	15/16"
M277	2/12	P20	27 7/8"	99°	15/16"	1 5/16"
	3/12	P30	27 7/8"	104°	15/16"	1 5/16"
M278	4/12	P40	29 1/2"	108°	1 5/16"	1 3/4"
	5/12	P50	29 1/2"	113°	1 5/16"	1 3/4"
	6/12	P60	29 1/2"	117°	1 5/16"	1 3/4"

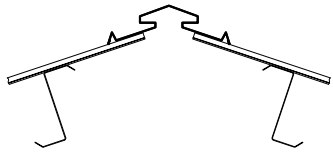

'COLOUR SIDE'

NOTE: TRIM IS SYMMETRICAL ABOUT \bar{C}

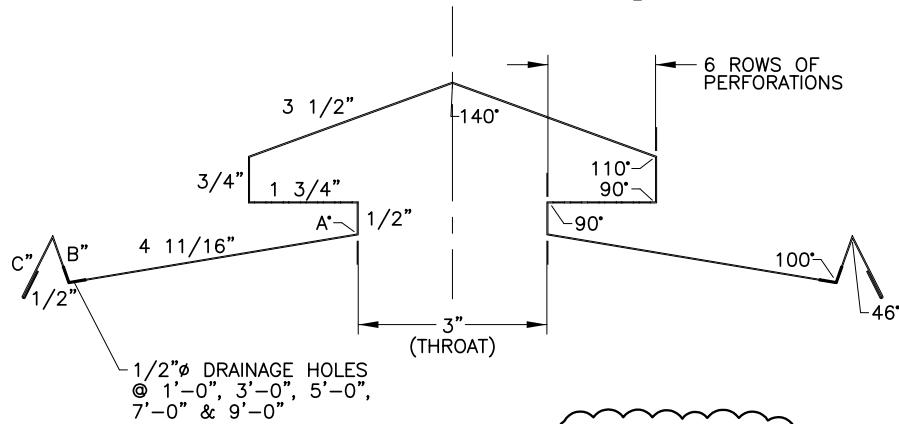

MAX. 10'-0" LENGTHS

GAUGE	WEIGHT
29	1.13#/FT.
28	1.42#/FT.
26	N/A
24	N/A

		7825 Springwater Road Aylmer, Ontario N5H 2R4 519-765-2244 www.exsteel.com	
		DATE: JAN 13/2011	DRAWN: AF
DATE:		CHECKED:	
DATE:		PROG:	
DATE:		ISSUED:	
DESCRIPTION: VENTED RIDGE CAP			
DRAWING #		M255, M277 & M278	

REV	DESCRIPTION	DATE	BY
2	ADDED NOTES	SEP 05/11	AF
1	GENERAL DETAIL REVIEW	JAN 24/11	AF

	PITCH	DESIG.	A°
	.25/12	P02	179°
	.5/12	P05	178°
	1/12	P10	175°
	2/12	P20	170°
	3/12	P30	166°
	4/12	P40	162°
	5/12	P50	158°
	6/12	P60	153°

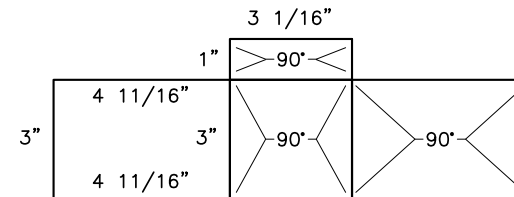
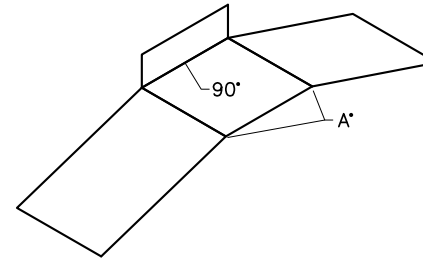

NOTE: TRIM IS SYMMETRICAL ABOUT \bar{C}

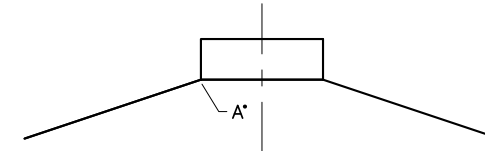

GIRTH: 4" x 12 7/16"

FINISH:
GALVALUME

GAUGE	WEIGHT
29	0.22#ea.
28	0.22#ea.
26	0.26#ea.
24	0.35#ea.

		7825 Springwater Road Aylmer, Ontario N5H 2R4 519-765-2244 www.exsteel.com	
		DATE: JUNE 19/2011	DRAWN: AF
DATE:		CHECKED:	
DATE:		PROG:	
DATE:		ISSUED:	
DESCRIPTION: TRANSITION CAP (M255, M277 & M278 - M01)			
DRAWING #		M283	

REV	DESCRIPTION	DATE	BY
1	GENERAL DETAIL REVIEW	SEP 05/11	AF

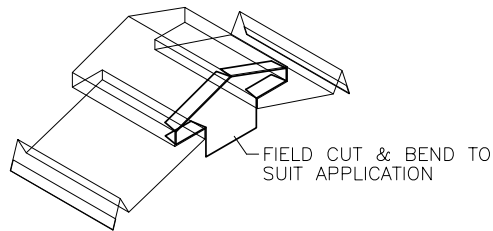
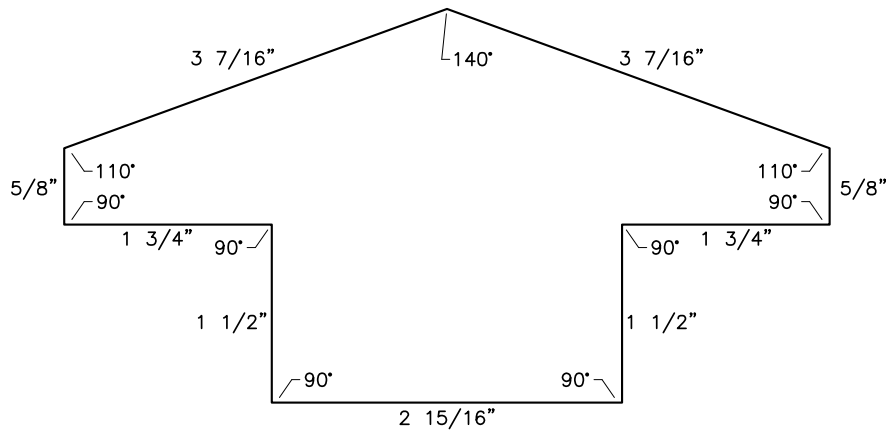

GAUGE	WEIGHT
29	0.05#/FT.
28	0.06#/FT.
26	0.08#/FT.
24	0.10#/FT.

exsteel BUILDING COMPONENTS	7825 Springwater Road Aylmer, Ontario N5H 2R4 519 - 765 - 2244 www.exsteel.com	
	DATE: JAN 14/2011	DRAWN: AF
	DATE:	CHECKED:
	DATE:	PROG:
DATE:	ISSUED:	

DESCRIPTION: END CAP - VENTED RIDGE CAP (M255, M277 & M278)

REV	DESCRIPTION	DATE	BY
1	GENERAL DETAIL REVIEW	SEP 05/11	AF

DRAWING # **M261**

'COLOUR SIDE'

NOTE: TRIM IS SYMMETRICAL ABOUT C

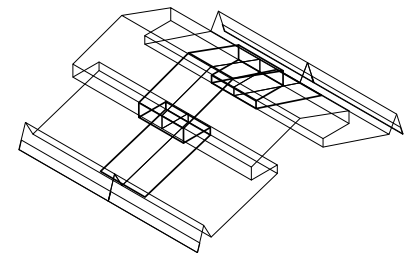
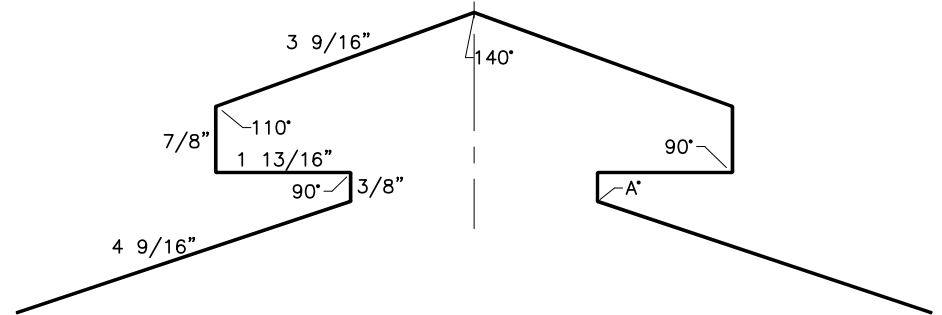

MATERIAL: 3"x22 3/8"

GAUGE	WEIGHT
29	0.23#/FT.
28	0.28#/FT.
26	0.34#/FT.
24	0.45#/FT.

exsteel BUILDING COMPONENTS	7825 Springwater Road Aylmer, Ontario N5H 2R4 519 - 765 - 2244 www.exsteel.com	
	DATE: JAN 14/2011	DRAWN: AF
	DATE:	CHECKED:
	DATE:	PROG:
DATE:	ISSUED:	

DESCRIPTION: VENTED RIDGE CAP STRAP (M255, M277 & M278)

REV	DESCRIPTION	DATE	BY
1	GENERAL DETAIL REVIEW	SEP 05/11	AF

DRAWING # **M262**

'COLOUR SIDE'

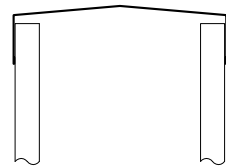
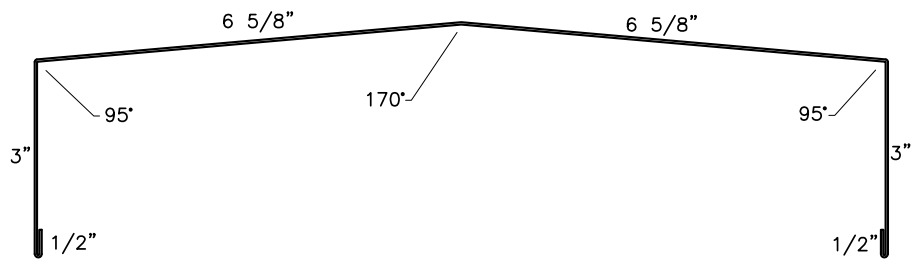

GIRTH: 20 1/4"

GAUGE	WEIGHT
29	0.95#/FT.
28	1.17#/FT.
26	1.36#/FT.
24	1.76#/FT.

exsteel BUILDING COMPONENTS		7825 Springwater Road Aylmer, Ontario N5H 2R4 519 - 765 - 2244 www.exsteel.com	
DATE:	JAN 30/1990	DRAWN:	BVERN
DATE:		CHECKED:	
DATE:		PROG:	
DATE:		ISSUED:	
DESCRIPTION: CAP TRIM			
DRAWING #		M35	
1	GENERAL DETAIL REVIEW	JAN 01/09	BJD
REV	DESCRIPTION	DATE	BY

PITCH	DESIG.	A°
.25/12	P02	178°
.5/12	P05	175°
1/12	P10	170°
2/12	P20	161°
3/12	P30	152°
4/12	P40	143°



'COLOUR SIDE'

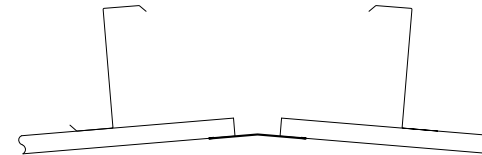

GIRTH: 9"

GAUGE	WEIGHT
29	0.44#/FT.
28	0.51#/FT.
26	0.59#/FT.
24	0.77#/FT.

exsteel BUILDING COMPONENTS		7825 Springwater Road Aylmer, Ontario N5H 2R4 519 - 765 - 2244 www.exsteel.com	
DATE:	JAN 26/1990	DRAWN:	BVERN
DATE:		CHECKED:	
DATE:		PROG:	
DATE:		ISSUED:	
DESCRIPTION: LINER RIDGE CAP			
DRAWING #		M26	
1	GENERAL DETAIL REVIEW	JAN 01/09	BJD
REV	DESCRIPTION	DATE	BY

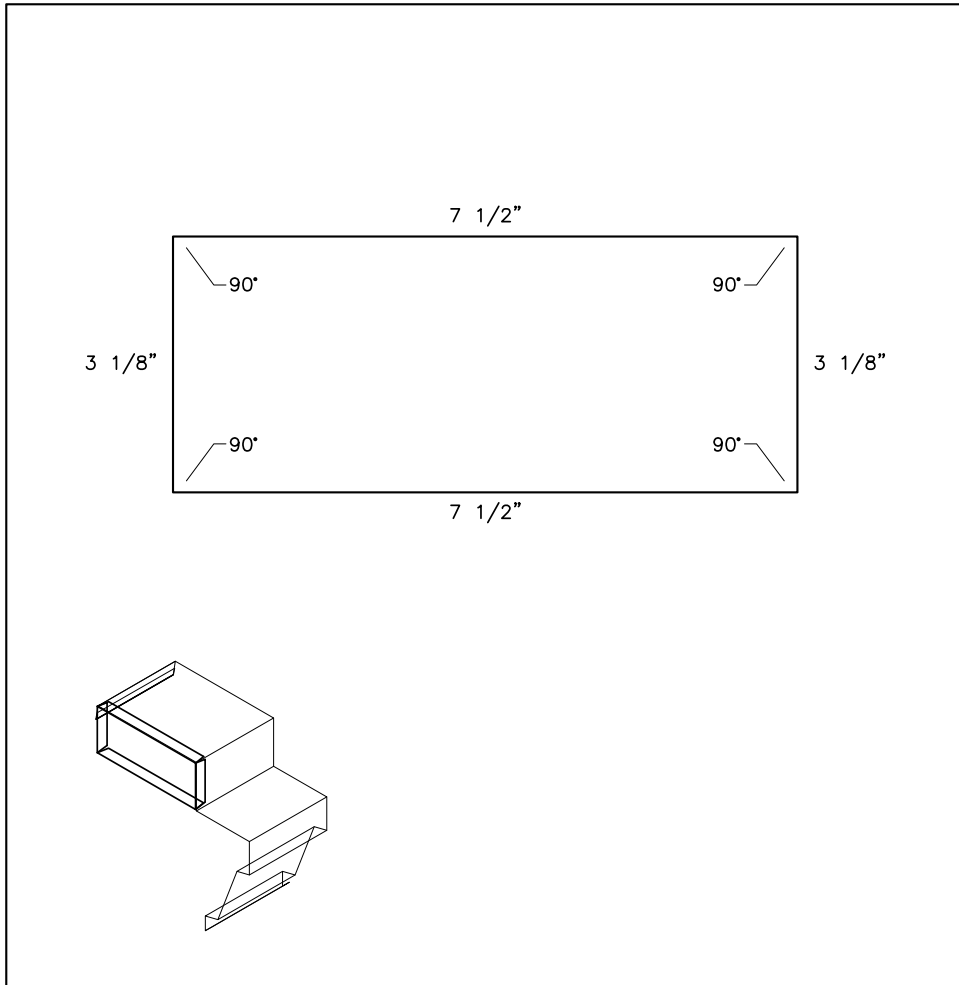

GAUGE	WEIGHT
29	2.72# ea.
28	3.01# ea.
26	3.61# ea.
24	4.82# ea.

exsteel BUILDING COMPONENTS	7825 Springwater Road Aylmer, Ontario N5H 2R4 519-765-2244 www.exsteel.com	
	DATE: DEC 03/2009	DRAWN: AF
	DATE:	CHECKED:
	DATE:	PROG:
DATE:	ISSUED:	
DESCRIPTION: END CAP - BOX VOID CLOSURE (M121)		
DRAWING # M74		

REV	DESCRIPTION	DATE	BY
1	GENERAL DETAIL REVIEW	JAN 01/09	BJD

PITCH	DESIG.	A'	B'	A''
.25/12	P02	177.6'	91.2'	4 1/16"
.5/12	P05	175.2'	92.4'	4 3/16"
1/12	P10	170.5'	94.8'	4 3/8"
2/12	P20	161.1'	99.5'	4 3/4"
3/12	P30	151.9'	104.0'	5 1/8"
4/12	P40	143.1'	108.4'	5 9/16"
5/12	P50	134.8'	112.6'	6 1/16"
6/12	P60	126.9'	116.6'	6 9/16"

NOTE: TRIM IS SYMMETRICAL ABOUT C

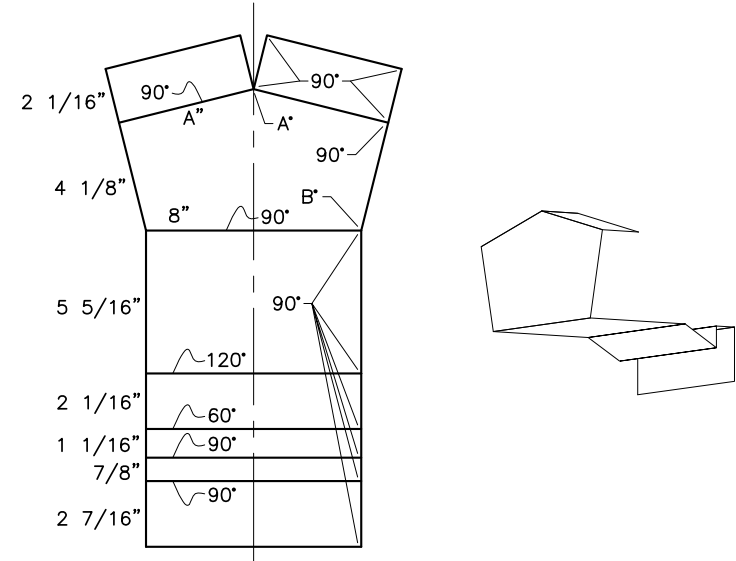

MATERIAL: 1'-8 11/16" x 1'-1 9/16" MAX.

GAUGE	WEIGHT
29	0.87#ea.
28	0.83#ea.
26	1.00#ea.
24	1.33#ea.

exsteel BUILDING COMPONENTS	7825 Springwater Road Aylmer, Ontario N5H 2R4 519-765-2244 www.exsteel.com	
	DATE: JAN 27/2011	DRAWN: AF
	DATE:	CHECKED:
	DATE:	PROG:
DATE:	ISSUED:	
DESCRIPTION: RIDGE BOX - GABLE (M237)		
DRAWING # M274		

REV	DESCRIPTION	DATE	BY
1	GENERAL DETAIL REVIEW	SEP 05/11	AF

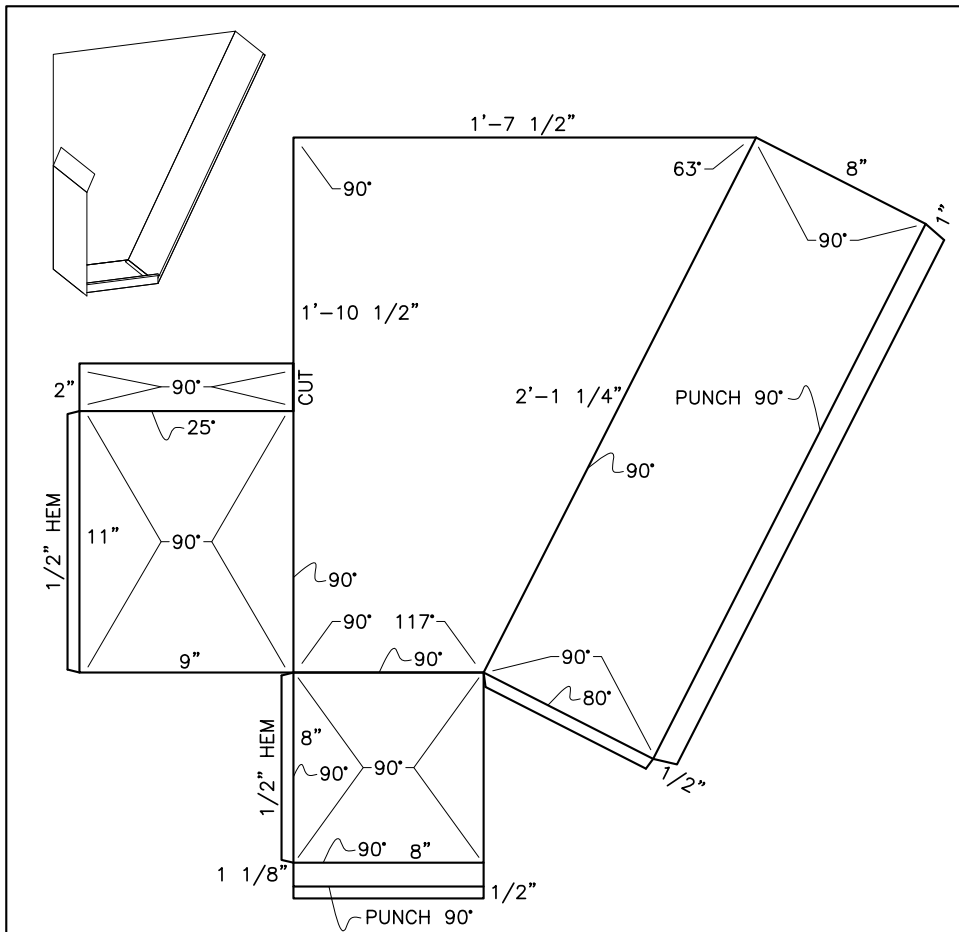

GIRTH: 2'-8 1/8" x 3'-0 1/2"

GAUGE	WEIGHT
29	5.85#ea.
28	5.63#ea.
26	6.75#ea.
24	9.00#ea.

		7825 Springwater Road Aylmer, Ontario N5H 2R4 519 - 765 - 2244 www.exsteel.com	
		DATE: JAN 28/2011	DRAWN: AF
		DATE:	CHECKED:
		DATE:	PROG:
		DATE:	ISSUED:
DESCRIPTION:			
CORNER BOX - GABLE (M237) - EAVE (M239 & M257) - RIGHT			
DRAWING #			M276

REV	DESCRIPTION	DATE	BY
2	REVISED DIMENSIONS	SEP 05/11	AF
1	GENERAL DETAIL REVIEW	APR 08/11	AF

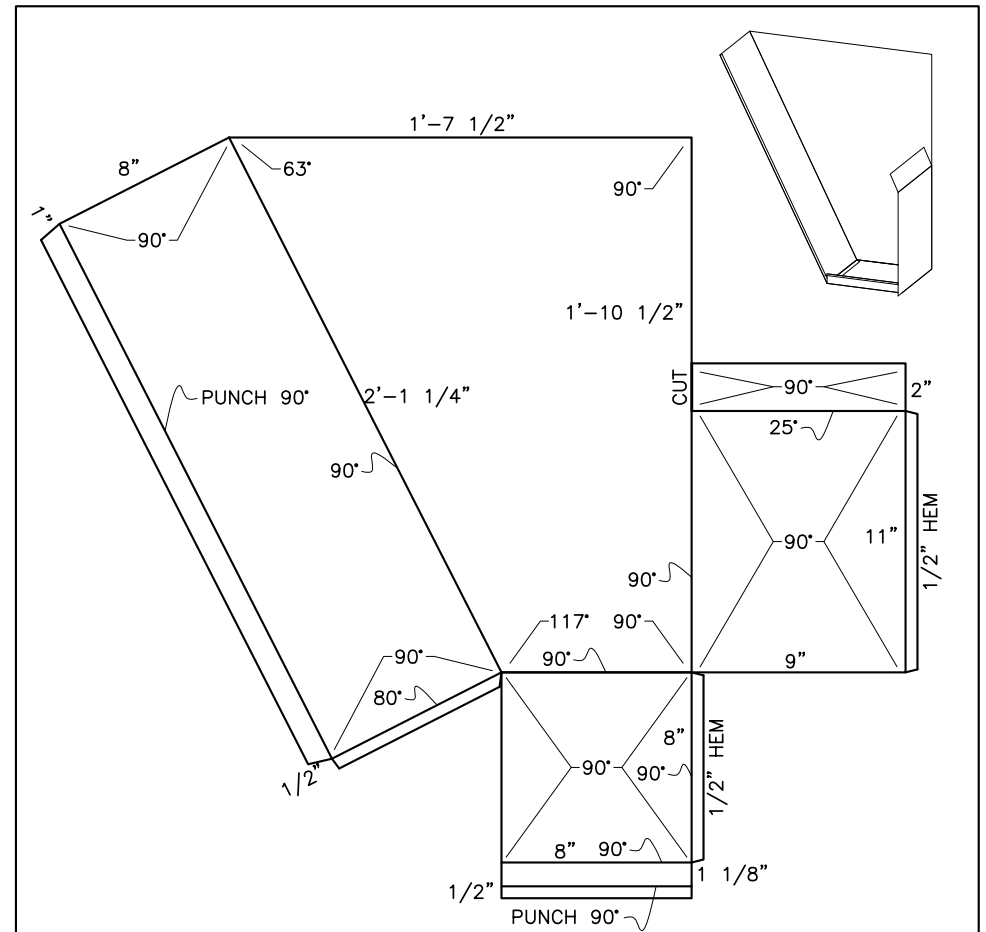

GIRTH: 2'-8 1/8" x 3'-0 1/2"

GAUGE	WEIGHT
29	5.85#ea.
28	5.63#ea.
26	6.75#ea.
24	9.00#ea.

		7825 Springwater Road Aylmer, Ontario N5H 2R4 519 - 765 - 2244 www.exsteel.com	
		DATE: JAN 28/2011	DRAWN: AF
		DATE:	CHECKED:
		DATE:	PROG:
		DATE:	ISSUED:
DESCRIPTION:			
CORNER BOX - GABLE (M237) - EAVE (M239 & M257) - LEFT			
DRAWING #			M275

REV	DESCRIPTION	DATE	BY
2	REVISED DIMENSIONS	SEP 05/11	AF
1	GENERAL DETAIL REVIEW	APR 08/11	AF

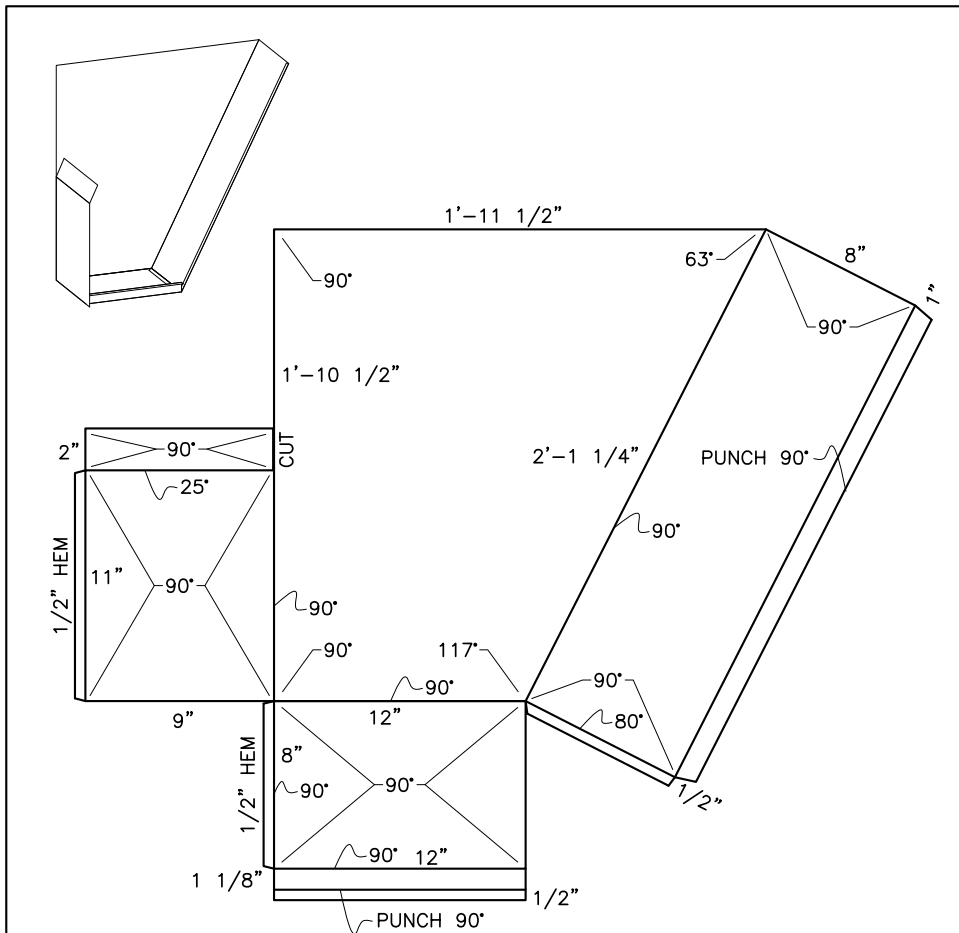

GIRTH: 2'-8 1/8" x 3'-4 1/2"

GAUGE	WEIGHT
29	5.92#ea.
28	5.69#ea.
26	6.83#ea.
24	9.11#ea.

		7825 Springwater Road Aylmer, Ontario N5H 2R4 519 - 765 - 2244 www.exsteel.com	
		DATE: July 05/2011	DRAWN: AF
DATE:		CHECKED:	
DATE:		PROG:	
DATE:		ISSUED:	
DESCRIPTION:			
CORNER BOX - GABLE (M237) - EAVE (M256 & M258) - RIGHT			
DRAWING #		M297	

REV	DESCRIPTION	DATE	BY
1	GENERAL DETAIL REVIEW	OCT 28/11	AF

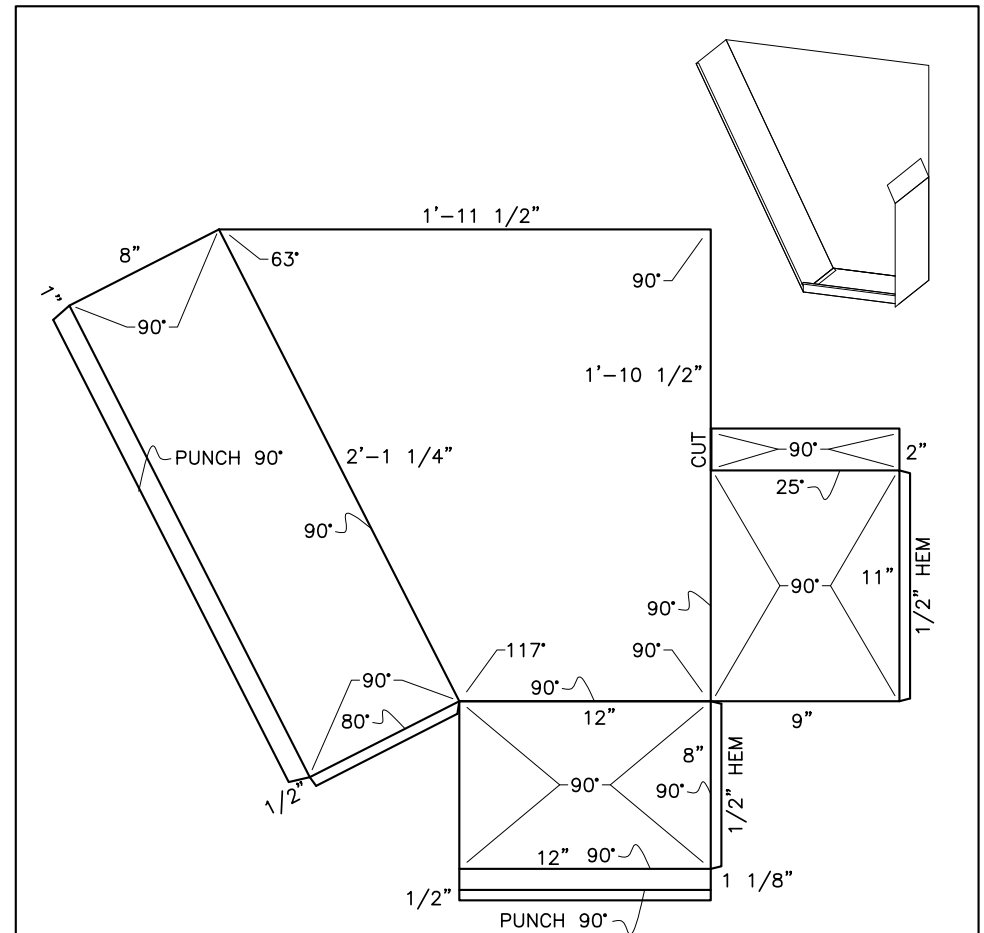

GIRTH: 2'-8 1/8" x 3'-4 1/2"

GAUGE	WEIGHT
29	5.92#ea.
28	5.69#ea.
26	6.83#ea.
24	9.11#ea.

		7825 Springwater Road Aylmer, Ontario N5H 2R4 519 - 765 - 2244 www.exsteel.com	
		DATE: July 05/2011	DRAWN: AF
DATE:		CHECKED:	
DATE:		PROG:	
DATE:		ISSUED:	
DESCRIPTION:			
CORNER BOX - GABLE (M237) - EAVE (M256 & M258) - LEFT			
DRAWING #		M296	

REV	DESCRIPTION	DATE	BY
1	GENERAL DETAIL REVIEW	OCT 28/11	AF

PITCH	DESIG.	A°
.25/12	P02	92°
.5/12	P05	93°
1/12	P10	95°
2/12	P20	100°
3/12	P30	104°
4/12	P40	109°

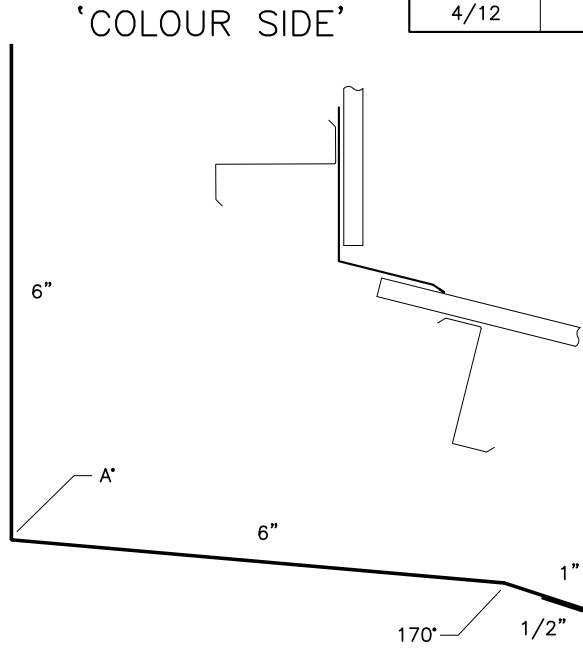

GIRTH: 13 1/2"

GAUGE	WEIGHT
29	0.62#/FT.
28	0.68#/FT.
26	0.82#/FT.
24	1.10#/FT.

		7825 Springwater Road Aylmer, Ontario N5H 2R4 519 - 765 - 2244 www.exsteel.com	
		DATE: JAN 27/2010	DRAWN: AF
DATE:		CHECKED:	
DATE:		PROG:	
DATE:		ISSUED:	
DESCRIPTION: HIGH/LOW EAVE/GABLE FLASHING			
DRAWING #		M234	
1	GENERAL DETAIL REVIEW	JAN 27/10	LD
REV	DESCRIPTION	DATE	BY

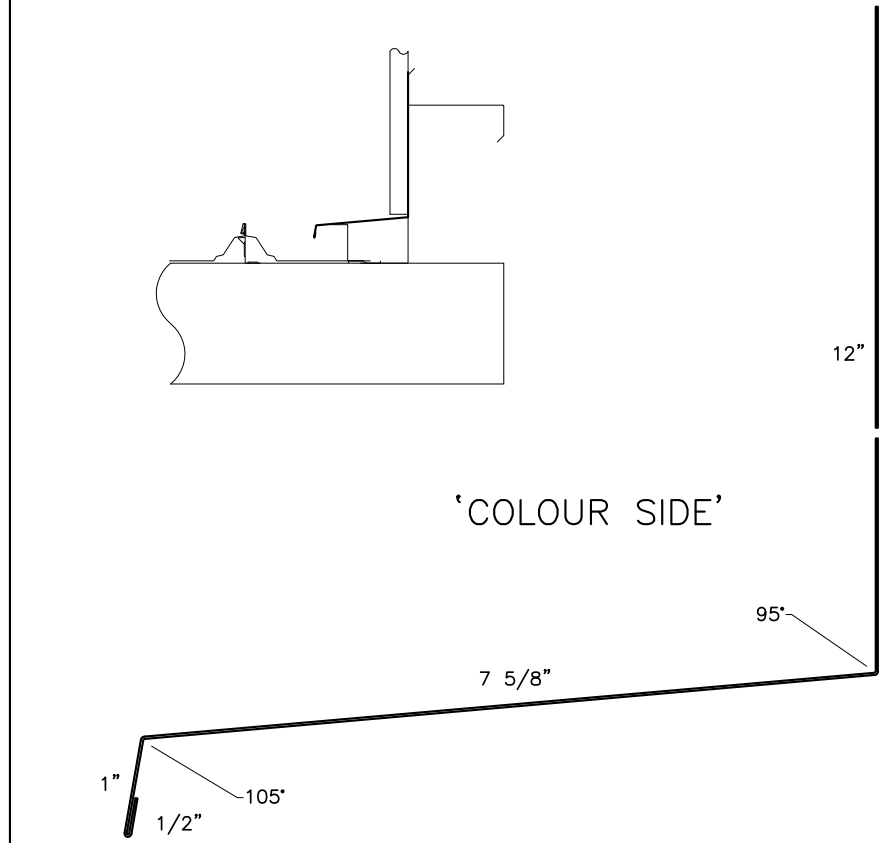

GIRTH: 21 1/8"

GAUGE	WEIGHT
29	1.07#/FT.
28	1.23#/FT.
26	1.43#/FT.
24	1.84#/FT.

		7825 Springwater Road Aylmer, Ontario N5H 2R4 519 - 765 - 2244 www.exsteel.com	
		DATE: JAN 26/1990	DRAWN: BVERN
DATE:		CHECKED:	
DATE:		PROG:	
DATE:		ISSUED:	
DESCRIPTION: HIGH/LOW GABLE FLASHING			
DRAWING #		M25	
1	GENERAL DETAIL REVIEW	JAN 01/09	BJD
REV	DESCRIPTION	DATE	BY

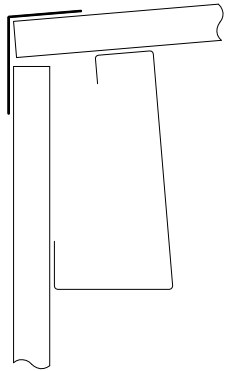

PITCH	DESIG.	A°
0/12	P00	90°
.25/12	P02	91°
.5/12	P05	92.5°
1/12	P10	94.75°
2/12	P20	99.5°
3/12	P30	104°
4/12	P40	108.5°

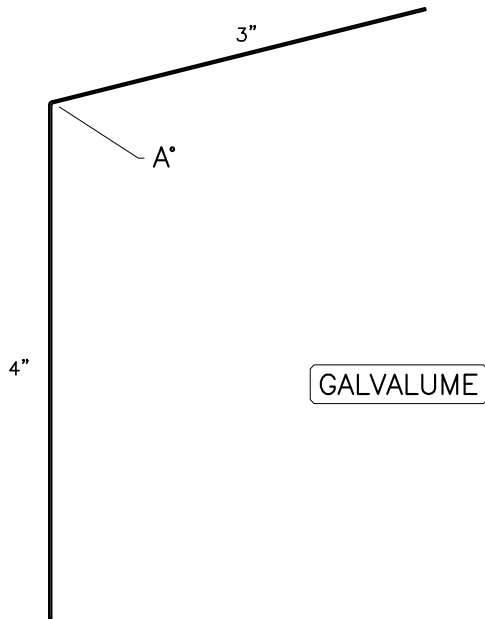

GIRTH: 7"

GAUGE	WEIGHT
29	0.33#/FT.
28	0.41#/FT.
26	0.48#/FT.
24	0.61#/FT.

		7825 Springwater Road Aylmer, Ontario N5H 2R4 519 - 765 - 2244 www.exsteel.com	
		DATE: MAY 10/1996	DRAWN: BVERN
DATE:		CHECKED:	
DATE:		PROG:	
DATE:		ISSUED:	
DESCRIPTION: EAVE/GABLE VAPOUR BARRIER FLASHING			
DRAWING #		M34	

REV	DESCRIPTION	DATE	BY
1	GENERAL DETAIL REVIEW	JAN 01/09	BJD

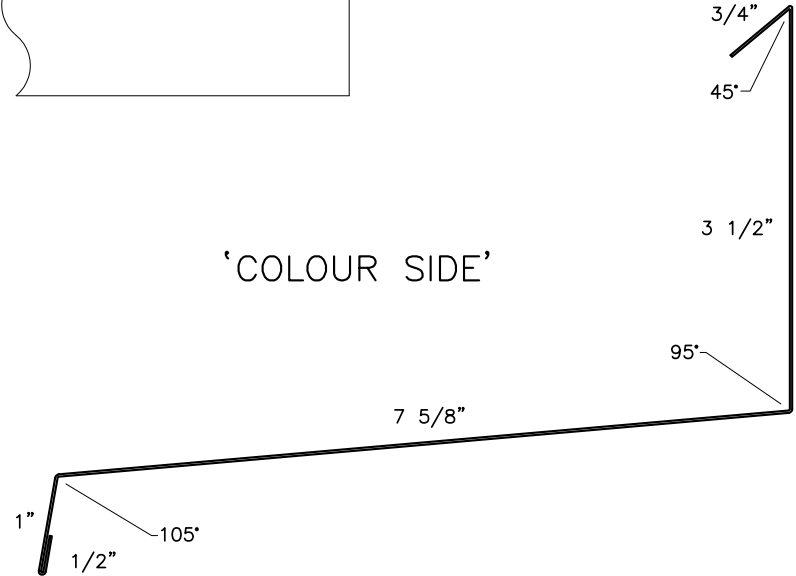
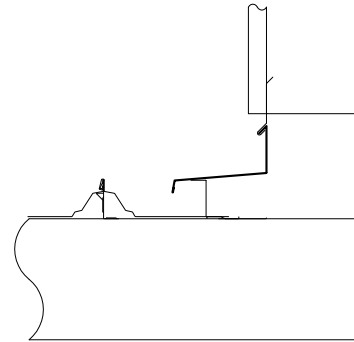

GIRTH: 13 3/8"

GAUGE	WEIGHT
29	0.63#/FT.
28	0.70#/FT.
26	0.84#/FT.
24	1.11#/FT.

		7825 Springwater Road Aylmer, Ontario N5H 2R4 519 - 765 - 2244 www.exsteel.com	
		DATE: NOV 27/2000	DRAWN: IMO
DATE:		CHECKED:	
DATE:		PROG:	
DATE:		ISSUED:	
DESCRIPTION: HIGH/LOW FLASHING - RTL-24 - FLOATING (LOWER PART)			
DRAWING #		M115	

REV	DESCRIPTION	DATE	BY
1	GENERAL DETAIL REVIEW	JAN 01/09	BJD

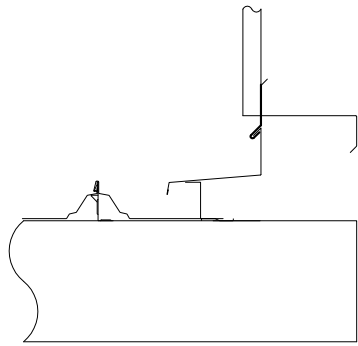

'COLOUR SIDE'

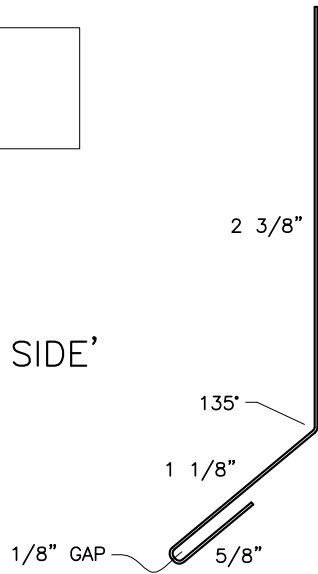

GIRTH: 4 1/8"

GAUGE	WEIGHT
29	0.19#/FT.
28	0.21#/FT.
26	0.26#/FT.
24	0.34#/FT.

		7825 Springwater Road Aylmer, Ontario N5H 2R4 519 - 765 - 2244 www.exsteel.com	
		DATE: NOV 27/2000	DRAWN: IMO
DATE:	CHECKED:	DATE:	PROG:
DATE:	ISSUED:	DATE:	ISSUED:
DESCRIPTION: HIGH/LOW FLASHING - RTL-24 - FLOATING (UPPER PART)			
DRAWING #		M116	

REV	DESCRIPTION	DATE	BY
1	GENERAL DETAIL REVIEW	JAN 01/09	BJD

'COLOUR SIDE'

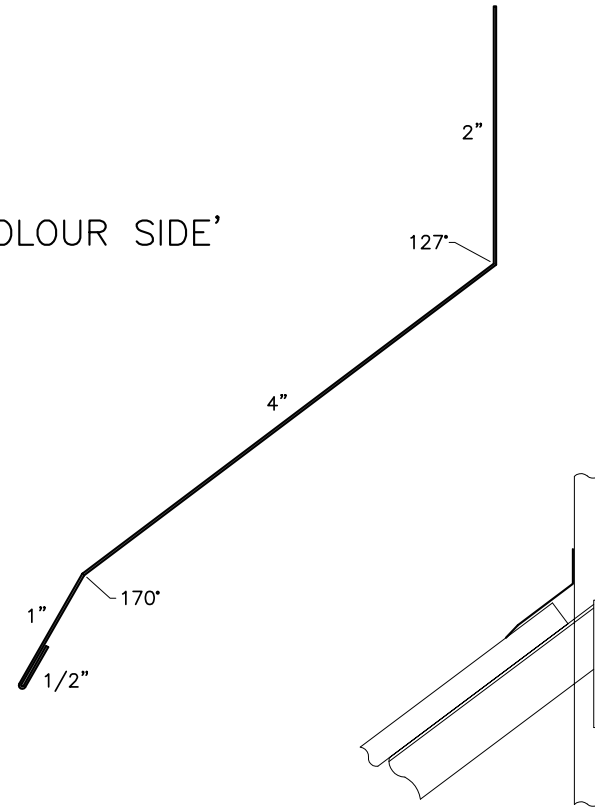

GIRTH: 7 1/2"

GAUGE	WEIGHT
29	0.35#/FT.
28	0.39#/FT.
26	0.47#/FT.
24	0.63#/FT.

		7825 Springwater Road Aylmer, Ontario N5H 2R4 519 - 765 - 2244 www.exsteel.com	
		DATE: JAN 23/2001	DRAWN: IMO
DATE:	CHECKED:	DATE:	PROG:
DATE:	ISSUED:	DATE:	ISSUED:
DESCRIPTION: CANOPY HIGH/LOW FLASHING			
DRAWING #		M117	

REV	DESCRIPTION	DATE	BY
1	GENERAL DETAIL REVIEW	JAN 01/09	BJD

PITCH	DESIG.	A°
.25/12	P02	178°
.5/12	P05	177°
1/12	P10	173°
2/12	P20	167°
3/12	P30	160°
4/12	P40	154°

'COLOUR SIDE'

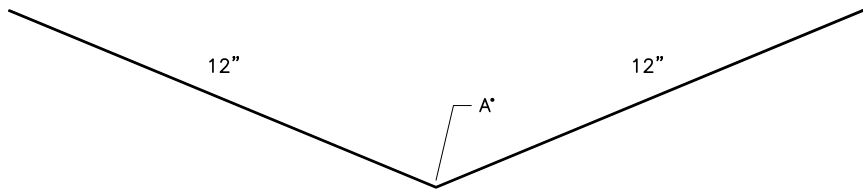

GIRTH: 24"

GAUGE	WEIGHT
29	1.10#/FT.
28	1.22#/FT.
26	1.46#/FT.
24	1.95#/FT.

 BUILDING COMPONENTS	7825 Springwater Road Aylmer, Ontario N5H 2R4 519 - 765 - 2244 www.exsteel.com	
	DATE: JAN 27/2010	DRAWN: AF
	DATE:	CHECKED:
	DATE:	PROG:
	DATE:	ISSUED:
DESCRIPTION: 'V' VALLEY TRIM - SCREW DOWN ROOF		
DRAWING #		M235

REV	DESCRIPTION	DATE	BY
1	GENERAL DETAIL REVIEW	JAN 27/10	LD

PITCH	DESIG.	A°
.25/12	P02	134°
.5/12	P05	134°
1/12	P10	132°
2/12	P20	129°
3/12	P30	125°
4/12	P40	122°

'COLOUR SIDE'

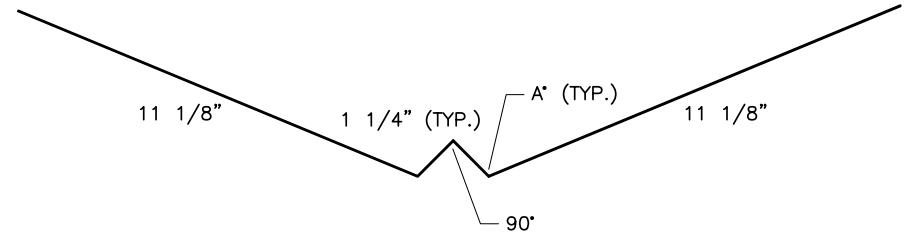

GIRTH: 24 3/4"

GAUGE	WEIGHT
29	1.16#/FT.
28	1.29#/FT.
26	1.55#/FT.
24	2.06#/FT.

 BUILDING COMPONENTS	7825 Springwater Road Aylmer, Ontario N5H 2R4 519 - 765 - 2244 www.exsteel.com	
	DATE: JAN 27/2010	DRAWN: AF
	DATE:	CHECKED:
	DATE:	PROG:
	DATE:	ISSUED:
DESCRIPTION: 'W' VALLEY TRIM - 24" - SCREW DOWN ROOF		
DRAWING #		M236

REV	DESCRIPTION	DATE	BY
3	DESCRIPTION UPDATED	FEB 04/11	AF
2	DIMENSIONS AND GIRTH REVISED	DEC 02/10	LD
1	GENERAL DETAIL REVIEW	JAN 27/10	LD

PITCH	DESIG.	A°
.25/12	P02	134°
.5/12	P05	134°
1/12	P10	132°
2/12	P20	129°
3/12	P30	125°
4/12	P40	122°

'COLOUR SIDE'

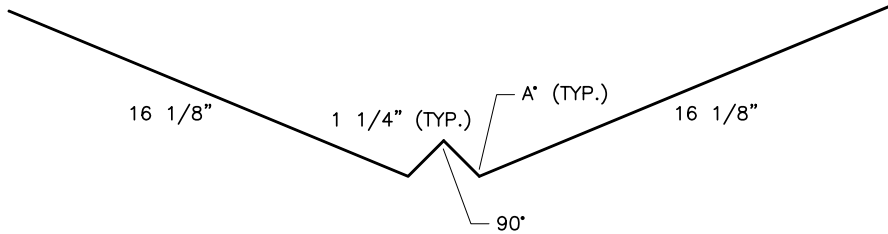

GIRTH: 34 3/4"

GAUGE	WEIGHT
29	1.63#/FT.
28	1.81#/FT.
26	2.17#/FT.
24	2.89#/FT.

 BUILDING COMPONENTS	7825 Springwater Road Aylmer, Ontario N5H 2R4 519 - 765 - 2244 www.exsteel.com	
	DATE: DEC 02/2010	DRAWN: LD
	DATE:	CHECKED:
	DATE:	PROG:
	DATE:	ISSUED:
DESCRIPTION: 'W' VALLEY TRIM - 34" - SCREW DOWN ROOF		
DRAWING #		M249

REV	DESCRIPTION	DATE	BY
1	GENERAL DETAIL REVIEW	DEC 02/10	LD

CHANGE OF PITCH	DESIG.	A°
1	P10	175.3°
2	P20	170.7°
3	P30	166.3°
4	P40	162.1°
5	P50	158.2°
6	P60	154.5°
7	P70	151.1°
8	P80	147.9°
9	P90	145.0°
10	P100	142.3°
11	P110	139.8°

'COLOUR SIDE'

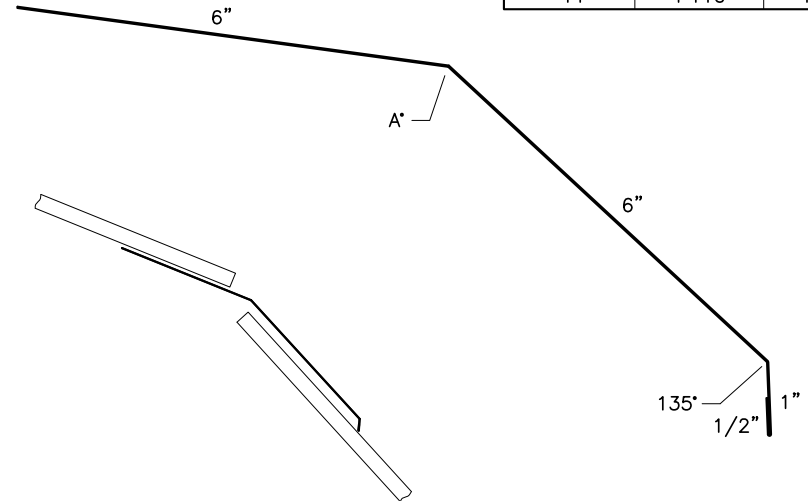

GIRTH: 13 1/2"

GAUGE	WEIGHT
29	0.74#/FT.
28	0.71#/FT.
26	0.85#/FT.
24	1.13#/FT.

 BUILDING COMPONENTS	7825 Springwater Road Aylmer, Ontario N5H 2R4 519 - 765 - 2244 www.exsteel.com	
	DATE: JAN 24/2011	DRAWN: AF
	DATE:	CHECKED:
	DATE:	PROG:
	DATE:	ISSUED:
DESCRIPTION: GAMBREL FLASHING		
DRAWING #		M238

REV	DESCRIPTION	DATE	BY
1	GENERAL DETAIL REVIEW	JUL 06/11	AF

CHANGE OF PITCH	DESIG.	A°
1	P10	175.3°
2	P20	170.7°
3	P30	166.3°
4	P40	162.1°
5	P50	158.2°
6	P60	154.5°
7	P70	151.1°
8	P80	147.9°
9	P90	145.0°
10	P100	142.3°
11	P110	139.8°

'COLOUR SIDE'

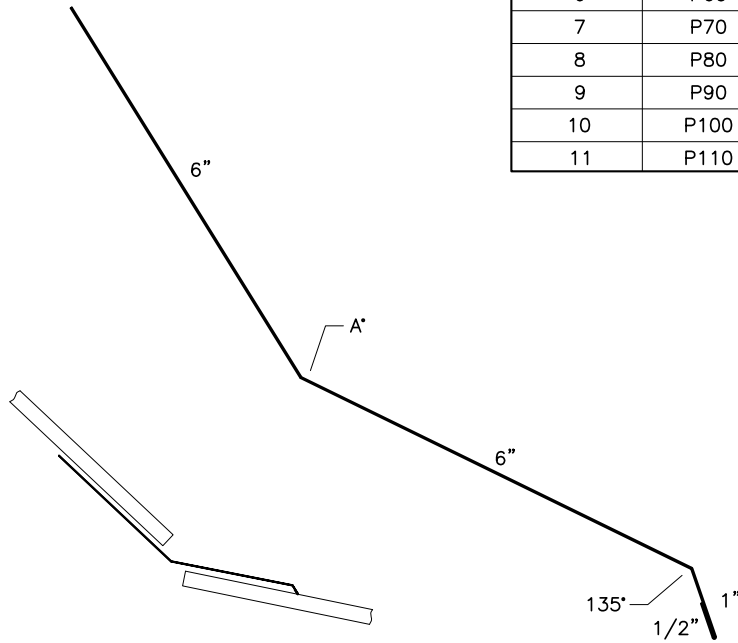

GIRTH: 13 1/2"

GAUGE	WEIGHT
29	0.74#/FT.
28	0.71#/FT.
26	0.85#/FT.
24	1.13#/FT.

 BUILDING COMPONENTS	7825 Springwater Road Aylmer, Ontario N5H 2R4 519 - 765 - 2244 www.exsteel.com	
	DATE: JAN 24/2011	DRAWN: AF
	DATE:	CHECKED:
	DATE:	PROG:
	DATE:	ISSUED:
DESCRIPTION: PITCH CHANGE		
DRAWING # M244		

REV	DESCRIPTION	DATE	BY
1	GENERAL DETAIL REVIEW	JUL 06/11	AF

'COLOUR SIDE'

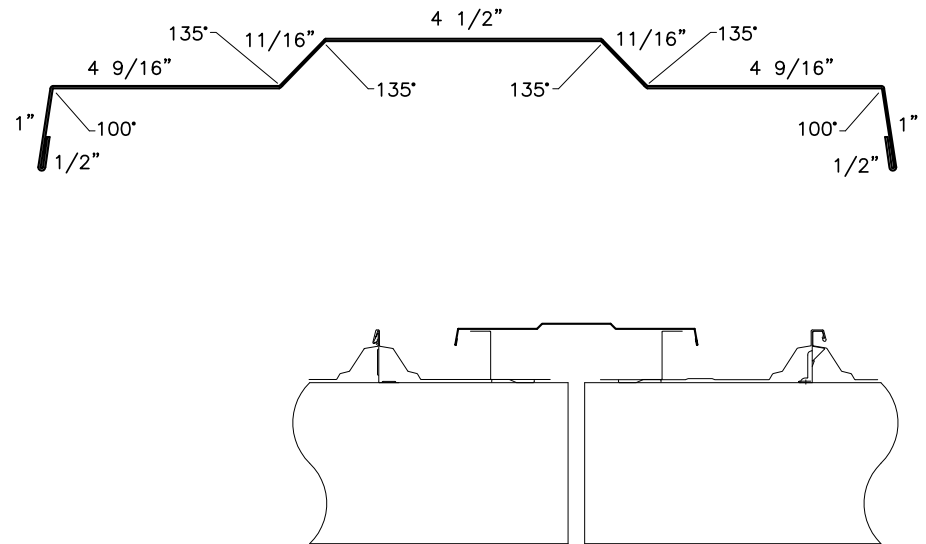

GIRTH: 18"

GAUGE	WEIGHT
29	0.84#/FT.
28	0.94#/FT.
26	1.13#/FT.
24	1.50#/FT.

 BUILDING COMPONENTS	7825 Springwater Road Aylmer, Ontario N5H 2R4 519 - 765 - 2244 www.exsteel.com	
	DATE: SEPT 17/2002	DRAWN: IMO
	DATE:	CHECKED:
	DATE:	PROG:
	DATE:	ISSUED:
DESCRIPTION: TRANSITION FLASHING - RTL-24		
DRAWING # M111		

REV	DESCRIPTION	DATE	BY
1	GENERAL DETAIL REVIEW	JAN 01/09	BJD

'COLOUR SIDE'

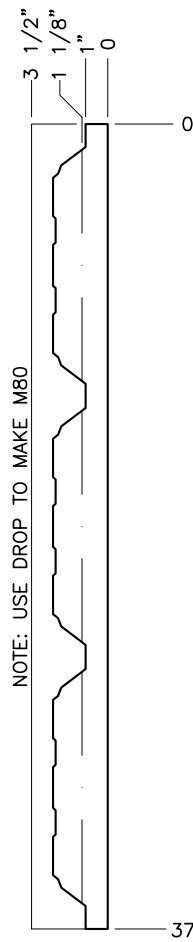
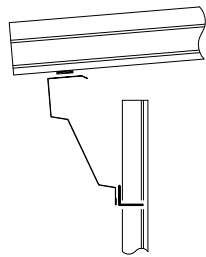
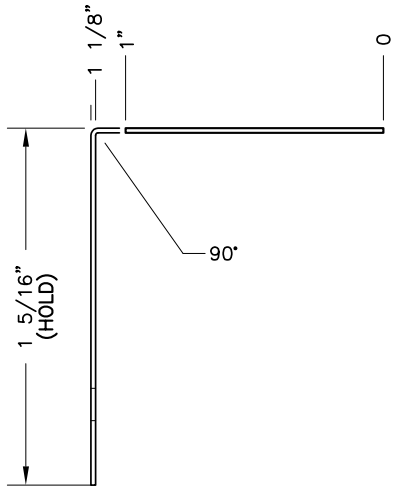

NOTE: USE DROP TO MAKE M80

MATERIAL:
CUT FROM 3 1/2"x37" BLANK

GAUGE	WEIGHT
29	0.35# ea.
28	0.38# ea.
26	0.45# ea.
24	0.58# ea.

		7825 Springwater Road Aylmer, Ontario N5H 2R4 519 - 765 - 2244 www.exsteel.com	
		DATE: SEPT 7/1995	DRAWN: BVERN
DATE:		CHECKED:	
DATE:		PROG:	
DATE:		ISSUED:	
DESCRIPTION: CLOSURE - METAL - STORM SEAL - LARGE TAB			
DRAWING #		M79	

REV	DESCRIPTION	DATE	BY
1	GENERAL DETAIL REVIEW	JAN 01/09	BJD

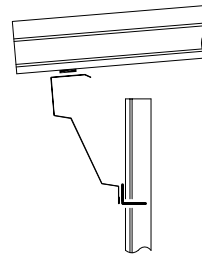
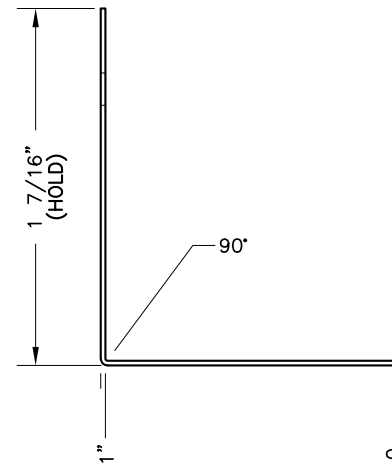

'COLOUR SIDE'

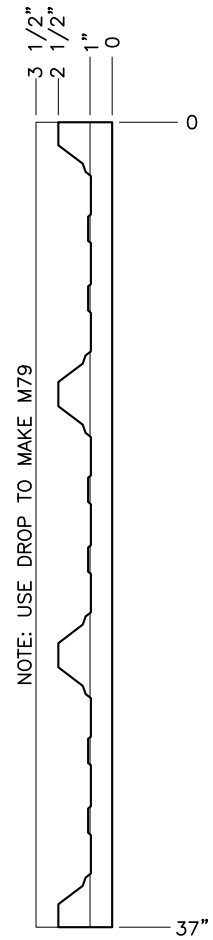

NOTE: USE DROP TO MAKE M79

MATERIAL:
CUT FROM 3 1/2"x37" BLANK

GAUGE	WEIGHT
29	0.35# ea.
28	0.25# ea.
26	0.28# ea.
24	0.37# ea.

		7825 Springwater Road Aylmer, Ontario N5H 2R4 519 - 765 - 2244 www.exsteel.com	
		DATE: SEPT 7/1995	DRAWN: BVERN
DATE:		CHECKED:	
DATE:		PROG:	
DATE:		ISSUED:	
DESCRIPTION: CLOSURE - METAL - STORM SEAL - SMALL TAB			
DRAWING #		M80	

REV	DESCRIPTION	DATE	BY
1	GENERAL DETAIL REVIEW	JAN 01/09	BJD

'COLOUR SIDE'

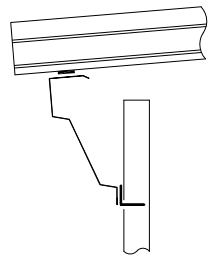
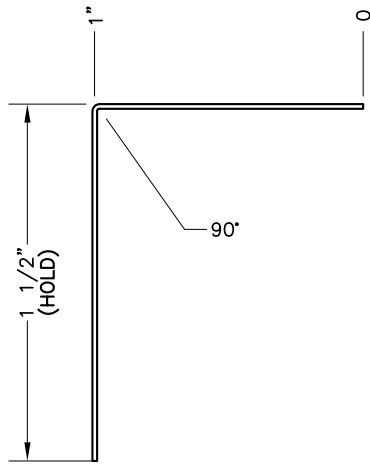

MATERIAL:
CUT FROM 3 1/2"x37" BLANK

GAUGE	WEIGHT
29	0.41# ea.
28	0.40# ea.
26	0.48# ea.
24	0.64# ea.

REV	DESCRIPTION	DATE	BY
1	GENERAL DETAIL REVIEW	MAR 21/11	AF

		7825 Springwater Road Aylmer, Ontario N5H 2R4 519 - 765 - 2244 www.exsteel.com	
		DATE: AUG. 11/2010	DRAWN: LD
DATE:		CHECKED:	
DATE:		PROG:	
DATE:		ISSUED:	
DESCRIPTION: CLOSURE - METAL - STRUC SEAL - LARGE TAB			
DRAWING #			M246

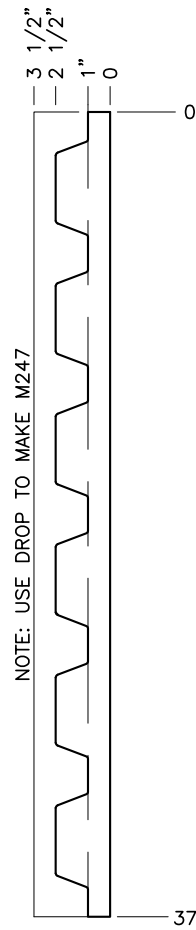

NOTE: USE DROP TO MAKE M247

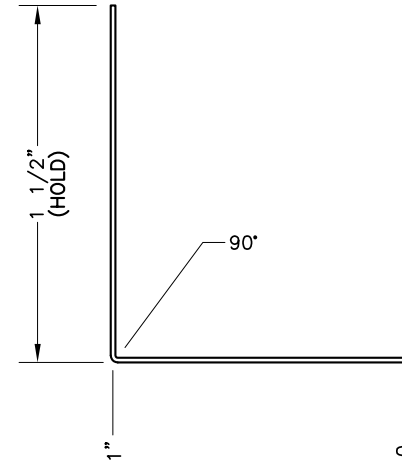

'COLOUR SIDE'

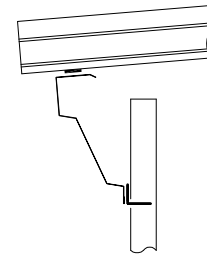

MATERIAL:
CUT FROM 3 1/2"x37" BLANK

GAUGE	WEIGHT
29	0.41# ea.
28	0.40# ea.
26	0.48# ea.
24	0.64# ea.

REV	DESCRIPTION	DATE	BY
1	GENERAL DETAIL REVIEW	MAR 21/11	AF

		7825 Springwater Road Aylmer, Ontario N5H 2R4 519 - 765 - 2244 www.exsteel.com	
		DATE: AUG. 11/2010	DRAWN: LD
DATE:		CHECKED:	
DATE:		PROG:	
DATE:		ISSUED:	
DESCRIPTION: CLOSURE - METAL - STRUC SEAL - SMALL TAB			
DRAWING #			M247

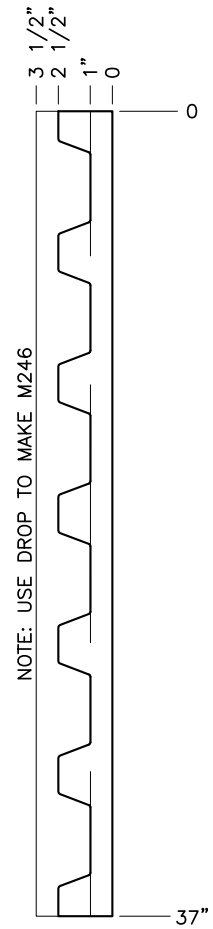

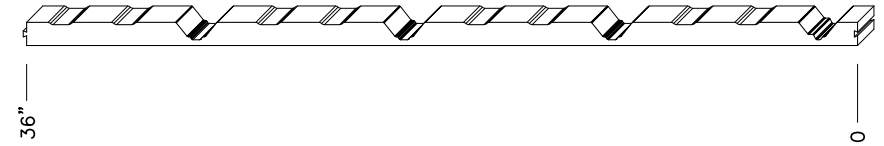
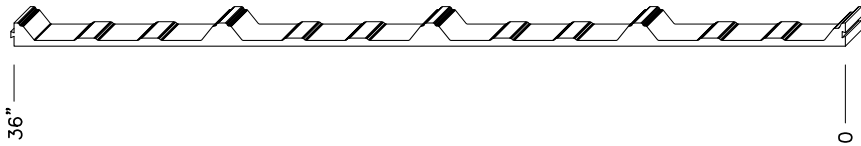

NOTE: USE DROP TO MAKE M246



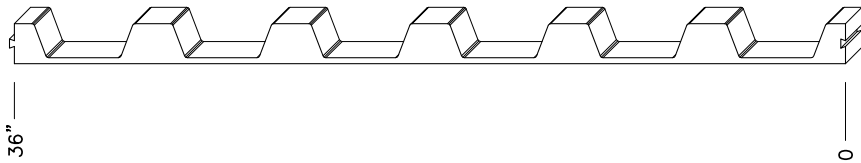

 BUILDING COMPONENTS		7825 Springwater Road Aylmer, Ontario N5H 2R4 519 - 765 - 2244 www.exsteel.com	
		DATE: DEC 03/2009	DRAWN: AF
DATE:		CHECKED:	
DATE:		PROG:	
DATE:		ISSUED:	
DESCRIPTION: CLOSURE - FOAM - VERSA SEAL - SMALL TAB			
DRAWING #		CLSVS-SM	
1	GENERAL DETAIL REVIEW	JAN 01/09	BJD
REV	DESCRIPTION	DATE	BY

 BUILDING COMPONENTS		7825 Springwater Road Aylmer, Ontario N5H 2R4 519 - 765 - 2244 www.exsteel.com	
		DATE: DEC 03/2009	DRAWN: AF
DATE:		CHECKED:	
DATE:		PROG:	
DATE:		ISSUED:	
DESCRIPTION: CLOSURE - FOAM - VERSA SEAL - LARGE TAB			
DRAWING #		CLSVS-LG	
1	GENERAL DETAIL REVIEW	JAN 01/09	BJD
REV	DESCRIPTION	DATE	BY



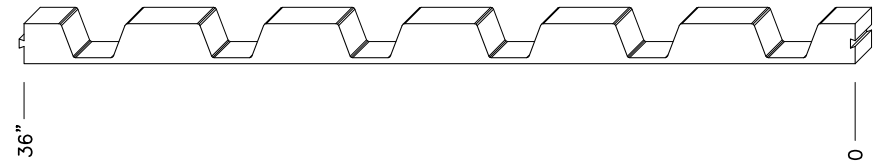

 BUILDING COMPONENTS		7825 Springwater Road Aylmer, Ontario N5H 2R4 519 - 765 - 2244 www.exsteel.com	
		DATE: DEC 03/2009	DRAWN: AF
DATE:		CHECKED:	
DATE:		PROG:	
DATE:		ISSUED:	
DESCRIPTION: CLOSURE — FOAM — STRUC SEAL — SMALL TAB			
DRAWING #		CLS WP—SM	
1	GENERAL DETAIL REVIEW	JAN 01/09	BJD
REV	DESCRIPTION	DATE	BY



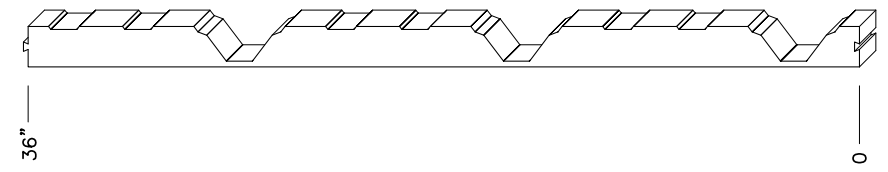
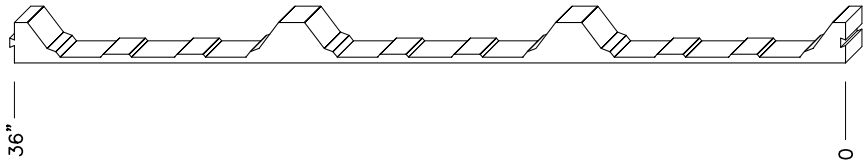

 BUILDING COMPONENTS		7825 Springwater Road Aylmer, Ontario N5H 2R4 519 - 765 - 2244 www.exsteel.com	
		DATE: DEC 03/2009	DRAWN: AF
DATE:		CHECKED:	
DATE:		PROG:	
DATE:		ISSUED:	
DESCRIPTION: CLOSURE — FOAM — STRUC SEAL — LARGE TAB			
DRAWING #		CLS WP—LG	
1	GENERAL DETAIL REVIEW	JAN 01/09	BJD
REV	DESCRIPTION	DATE	BY

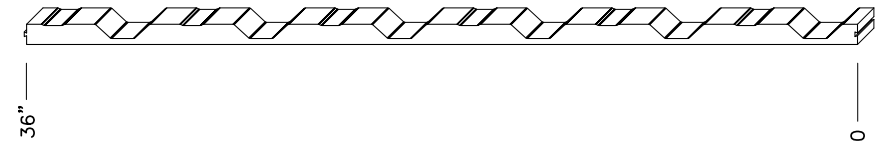
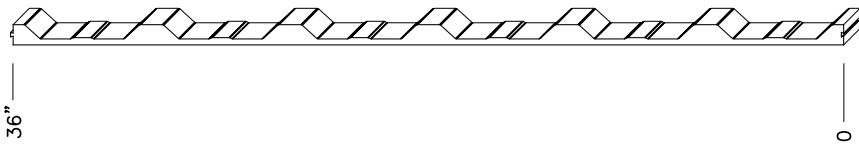

 BUILDING COMPONENTS		7825 Springwater Road Aylmer, Ontario N5H 2R4 519 - 765 - 2244 www.exsteel.com	
		DATE: DEC 03/2009	DRAWN: AF
DATE:		CHECKED:	
DATE:		PROG:	
DATE:		ISSUED:	
DESCRIPTION: CLOSURE - FOAM - STORM SEAL - SMALL TAB			
DRAWING #		CLS-SM	
1	GENERAL DETAIL REVIEW	JAN 01/09	BJD
REV	DESCRIPTION	DATE	BY

 BUILDING COMPONENTS		7825 Springwater Road Aylmer, Ontario N5H 2R4 519 - 765 - 2244 www.exsteel.com	
		DATE: DEC 03/2009	DRAWN: AF
DATE:		CHECKED:	
DATE:		PROG:	
DATE:		ISSUED:	
DESCRIPTION: CLOSURE - FOAM - STORM SEAL - LARGE TAB			
DRAWING #		CLS-LG	
1	GENERAL DETAIL REVIEW	JAN 01/09	BJD
REV	DESCRIPTION	DATE	BY



 BUILDING COMPONENTS		7825 Springwater Road Aylmer, Ontario N5H 2R4 519 - 765 - 2244 www.exsteel.com		
		DATE: DEC 03/2009	DRAWN: AF	
DATE:	CHECKED:	DATE:	PROG:	
DATE:	ISSUED:	DESCRIPTION: CLOSURE - FOAM - DIAMOND SEAL - SMALL TAB		
1	GENERAL DETAIL REVIEW	JAN 01/09	BJD	DRAWING # CLSDS-SM
REV	DESCRIPTION	DATE	BY	

 BUILDING COMPONENTS		7825 Springwater Road Aylmer, Ontario N5H 2R4 519 - 765 - 2244 www.exsteel.com		
		DATE: DEC 03/2009	DRAWN: AF	
DATE:	CHECKED:	DATE:	PROG:	
DATE:	ISSUED:	DESCRIPTION: CLOSURE - FOAM - DIAMOND SEAL - LARGE TAB		
1	GENERAL DETAIL REVIEW	JAN 01/09	BJD	DRAWING # CLSDS-LG
REV	DESCRIPTION	DATE	BY	

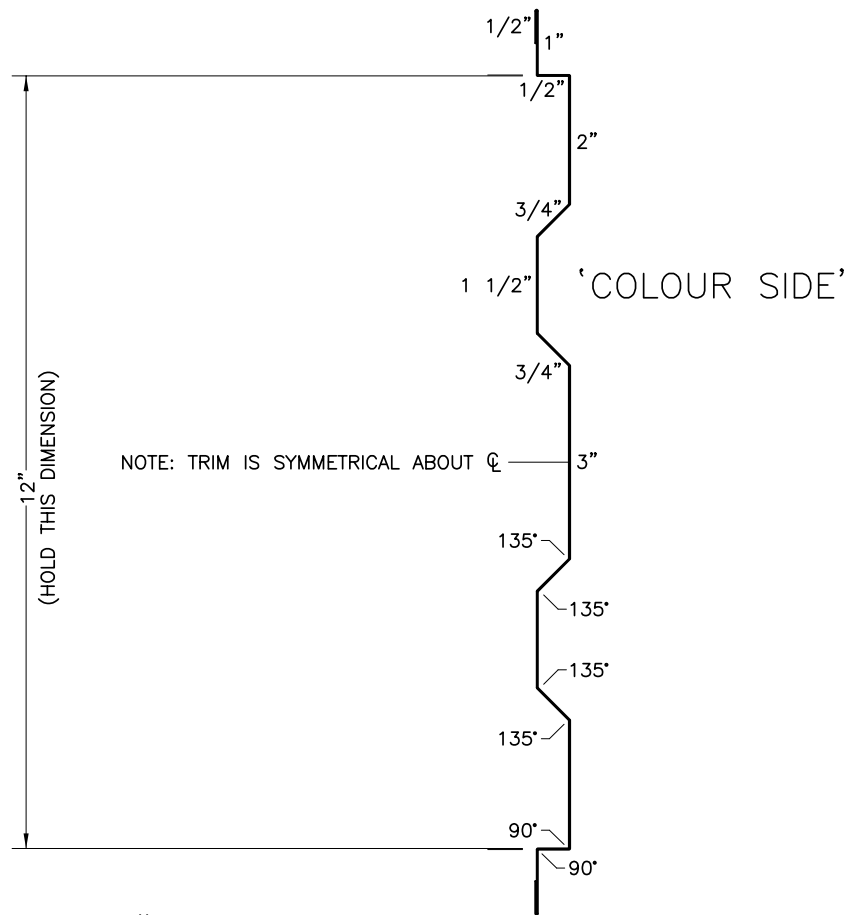

GIRTH: 17"

GAUGE	WEIGHT
29	0.93#/FT.
28	0.89#/FT.
26	1.07#/FT.
24	1.42#/FT.

exsteel BUILDING COMPONENTS		7825 Springwater Road Aylmer, Ontario N5H 2R4 519 - 765 - 2244 www.exsteel.com	
DATE:	JAN 18/2011	DRAWN:	AF
DATE:		CHECKED:	
DATE:		PROG:	
DATE:		ISSUED:	
DESCRIPTION: ACCENT BAND #1			
DRAWING #		M264	
1	GENERAL DETAIL REVIEW	MAR 14/11	AF
REV	DESCRIPTION	DATE	BY

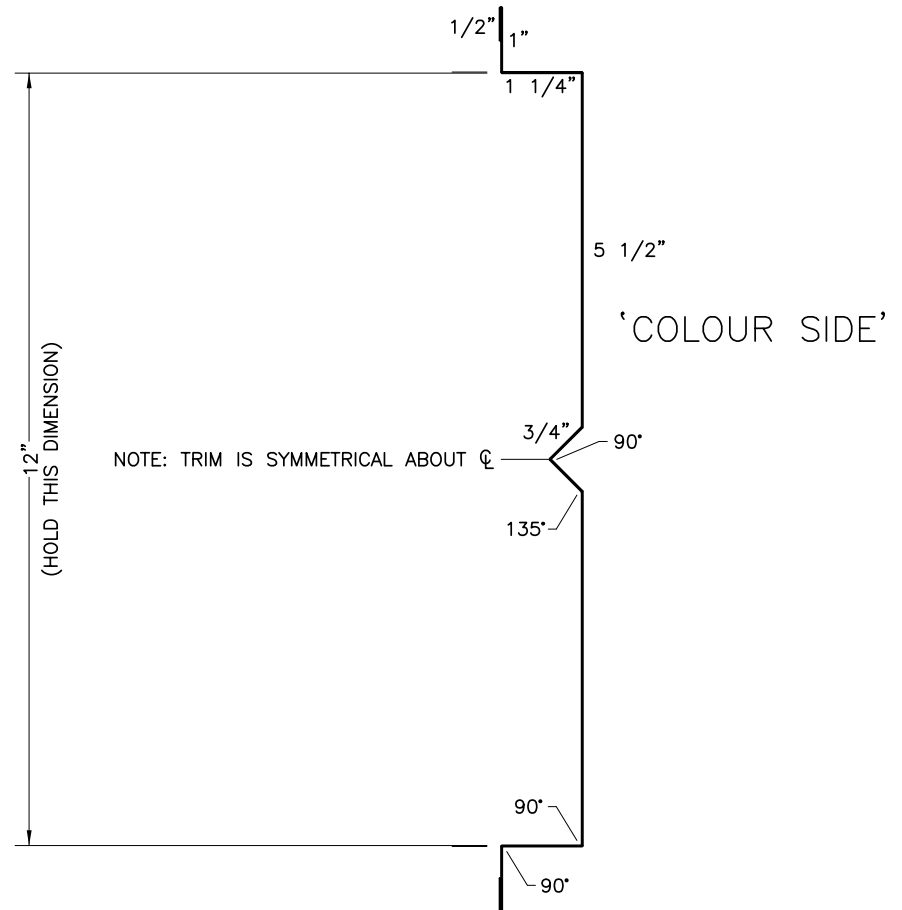

GIRTH: 18"

GAUGE	WEIGHT
29	0.98#/FT.
28	0.94#/FT.
26	1.13#/FT.
24	1.50#/FT.

exsteel BUILDING COMPONENTS		7825 Springwater Road Aylmer, Ontario N5H 2R4 519 - 765 - 2244 www.exsteel.com	
DATE:	JAN 18/2011	DRAWN:	AF
DATE:		CHECKED:	
DATE:		PROG:	
DATE:		ISSUED:	
DESCRIPTION: ACCENT BAND #2			
DRAWING #		M265	
1	GENERAL DETAIL REVIEW		
REV	DESCRIPTION	DATE	BY

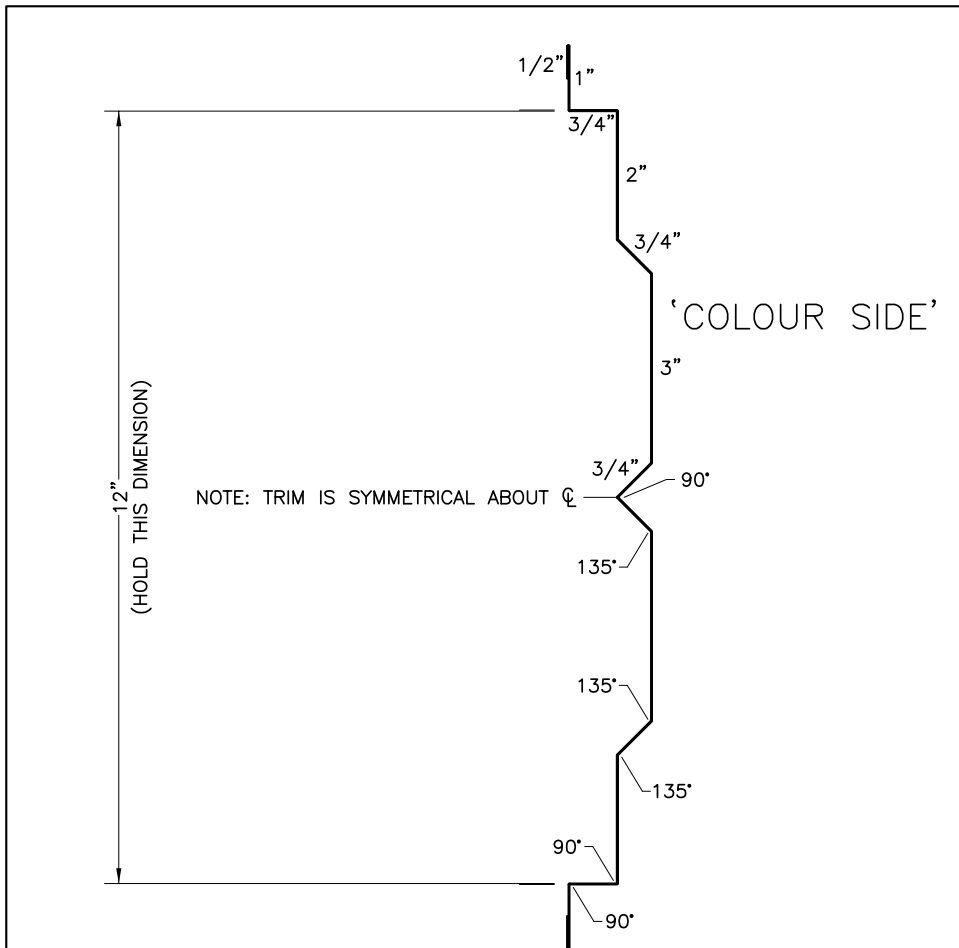

GIRTH: 17 1/2"

GAUGE	WEIGHT
29	0.95#/FT.
28	0.92#/FT.
26	1.10#/FT.
24	1.46#/FT.

		7825 Springwater Road Aylmer, Ontario N5H 2R4 519 - 765 - 2244 www.exsteel.com	
		DATE: JAN 18/2011	DRAWN: AF
DATE:		CHECKED:	
DATE:		PROG:	
DATE:		ISSUED:	
DESCRIPTION: ACCENT BAND #3			
DRAWING #		M266	
1	GENERAL DETAIL REVIEW	MAR 14/11	AF
REV	DESCRIPTION	DATE	BY

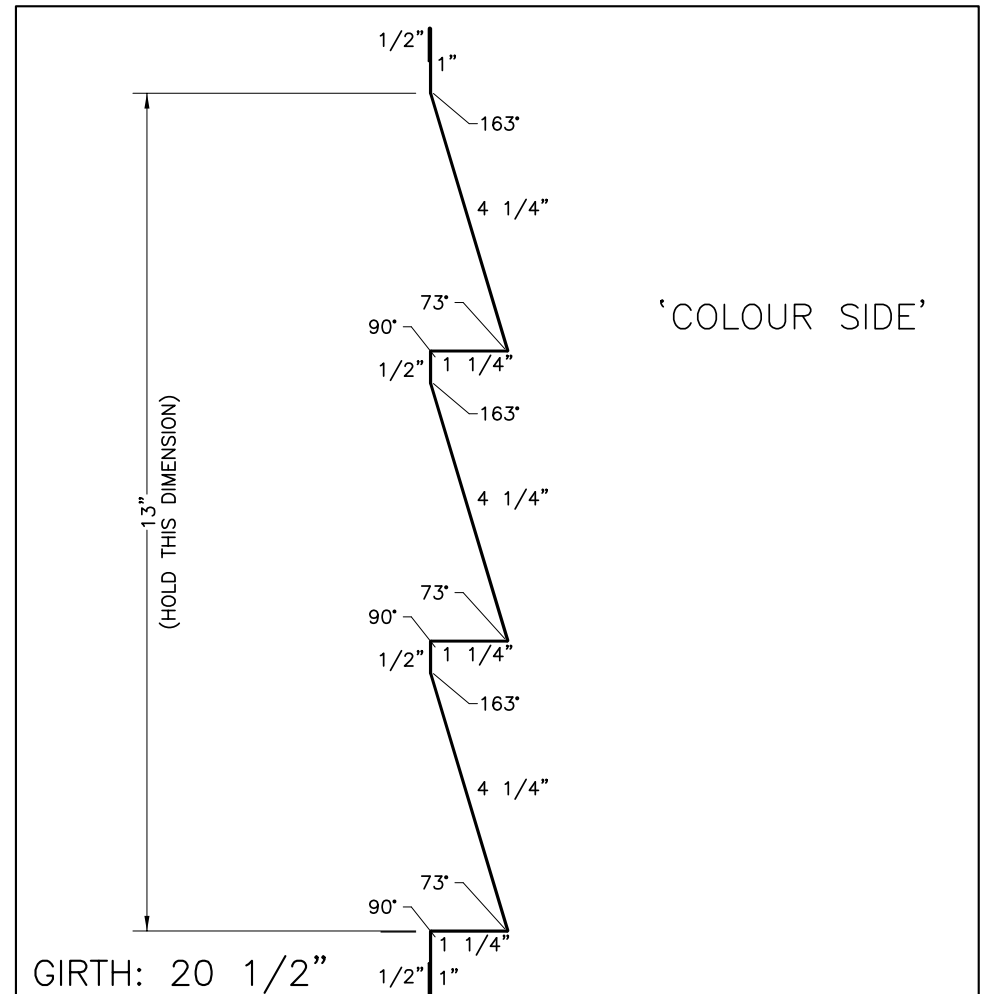

GIRTH: 20 1/2"

GAUGE	WEIGHT
29	1.12#/FT.
28	1.07#/FT.
26	1.29#/FT.
24	1.71#/FT.

		7825 Springwater Road Aylmer, Ontario N5H 2R4 519 - 765 - 2244 www.exsteel.com	
		DATE: JAN 18/2011	DRAWN: AF
DATE:		CHECKED:	
DATE:		PROG:	
DATE:		ISSUED:	
DESCRIPTION: ACCENT BAND #4			
DRAWING #		M267	
1	GENERAL DETAIL REVIEW	MAR 14/11	AF
REV	DESCRIPTION	DATE	BY

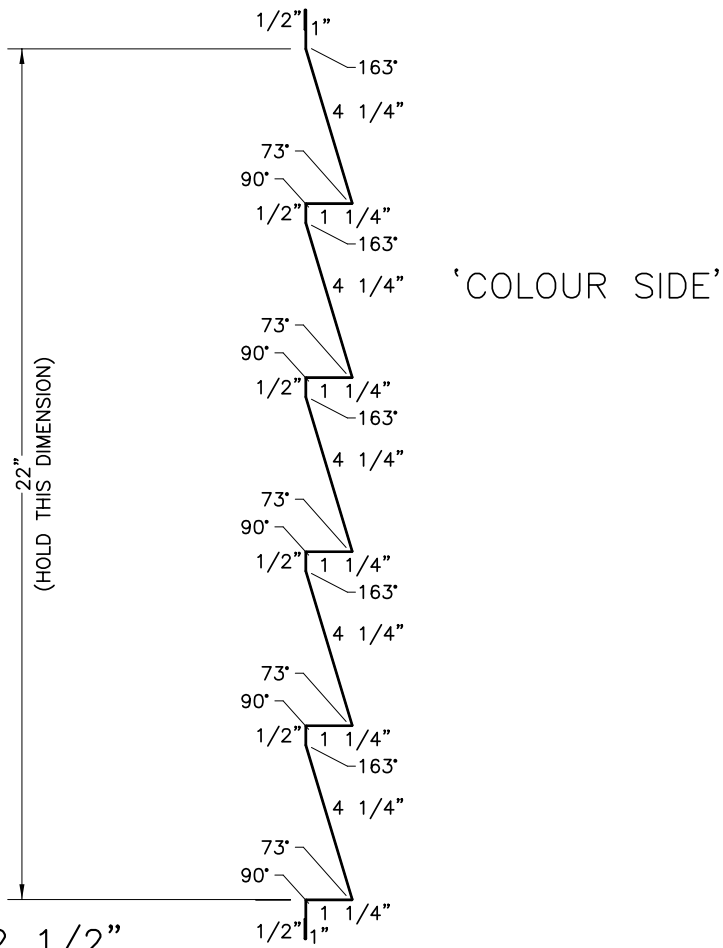

GIRTH: 32 1/2"

GAUGE	WEIGHT
29	1.77#/FT.
28	1.70#/FT.
26	2.04#/FT.
24	2.71#/FT.

		7825 Springwater Road Aylmer, Ontario N5H 2R4 519 - 765 - 2244 www.exsteel.com	
		DATE: JAN 18/2011	DRAWN: AF
DATE:		CHECKED:	
DATE:		PROG:	
DATE:		ISSUED:	
DESCRIPTION: ACCENT BAND #5			
DRAWING #		M268	
1	GENERAL DETAIL REVIEW	MAR 14/11	AF
REV	DESCRIPTION	DATE	BY

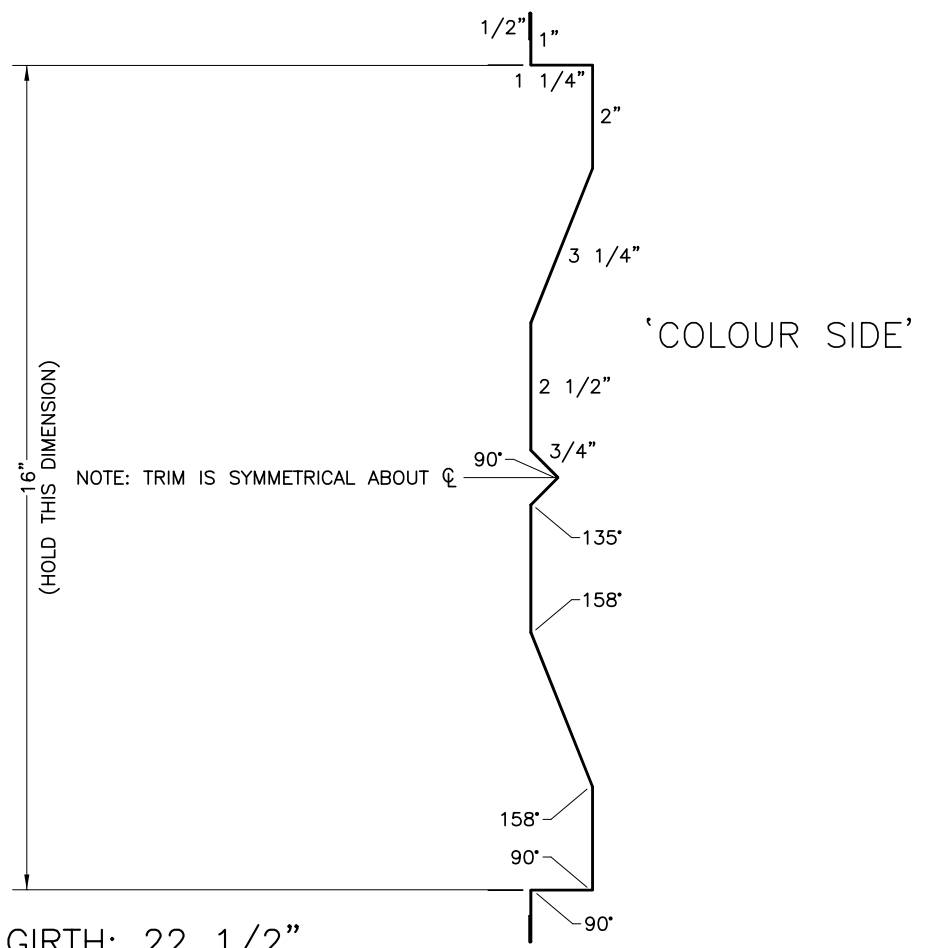

GIRTH: 22 1/2"

GAUGE	WEIGHT
29	1.22#/FT.
28	1.18#/FT.
26	1.41#/FT.
24	1.88#/FT.

		7825 Springwater Road Aylmer, Ontario N5H 2R4 519 - 765 - 2244 www.exsteel.com	
		DATE: JAN 18/2011	DRAWN: AF
DATE:		CHECKED:	
DATE:		PROG:	
DATE:		ISSUED:	
DESCRIPTION: ACCENT BAND #6			
DRAWING #		M269	
1	GENERAL DETAIL REVIEW	MAR 14/11	AF
REV	DESCRIPTION	DATE	BY

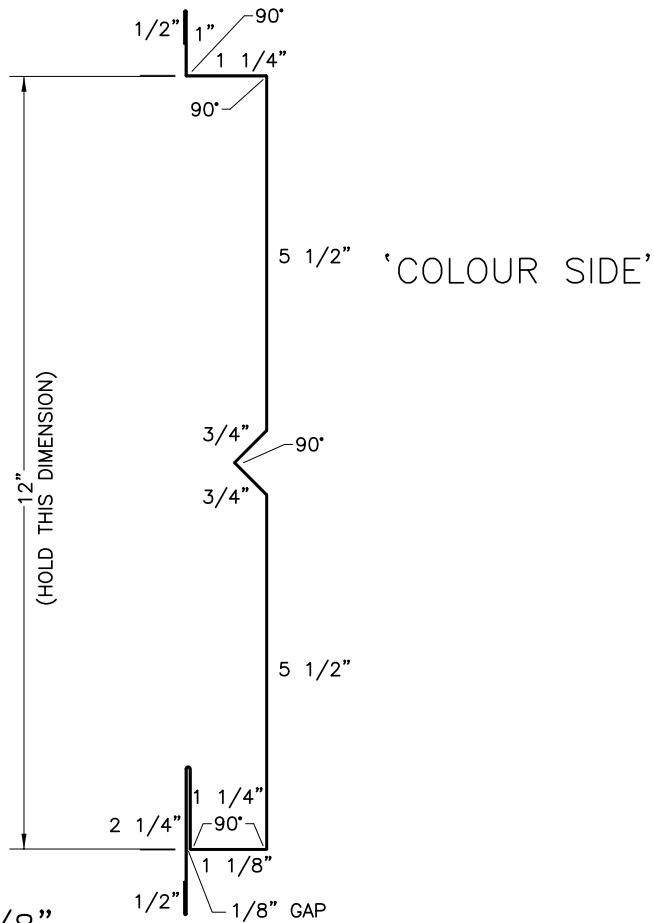

GIRTH: 20 3/8"

GAUGE	WEIGHT
29	1.11#/FT.
28	1.07#/FT.
26	1.28#/FT.
24	1.70#/FT.

exsteel BUILDING COMPONENTS		7825 Springwater Road Aylmer, Ontario N5H 2R4 519 - 765 - 2244 www.exsteel.com	
DATE:	JAN 18/2011	DRAWN:	AF
DATE:		CHECKED:	
DATE:		PROG:	
DATE:		ISSUED:	
DESCRIPTION: ACCENT BAND #7			
DRAWING #		M270	
1	GENERAL DETAIL REVIEW	MAR 14/11	AF
REV	DESCRIPTION	DATE	BY

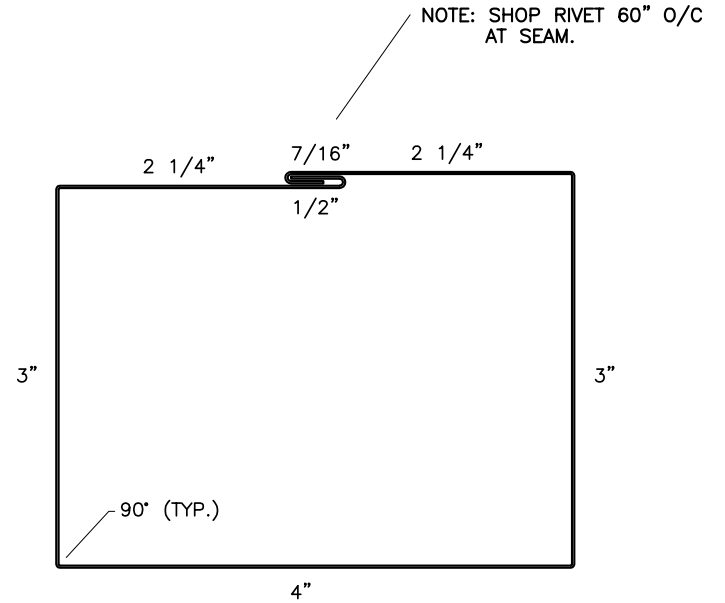

'COLOUR SIDE'

GIRTH: 15 7/16"

GAUGE	WEIGHT
29	0.70#/FT.
28	0.80#/FT.
26	0.96#/FT.
24	1.28#/FT.

exsteel BUILDING COMPONENTS		7825 Springwater Road Aylmer, Ontario N5H 2R4 519 - 765 - 2244 www.exsteel.com	
DATE:	JAN 24/1990	DRAWN:	BVERN
DATE:		CHECKED:	
DATE:		PROG:	
DATE:		ISSUED:	
DESCRIPTION: DOWNSPOUT - 4"x3"			
DRAWING #		M14	
1	GENERAL DETAIL REVIEW	JAN 01/09	BJD
REV	DESCRIPTION	DATE	BY

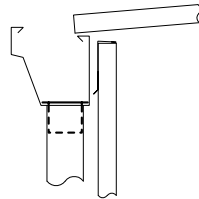
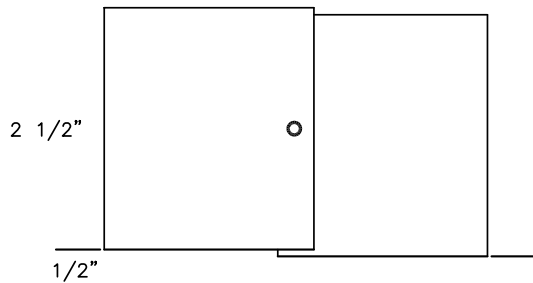
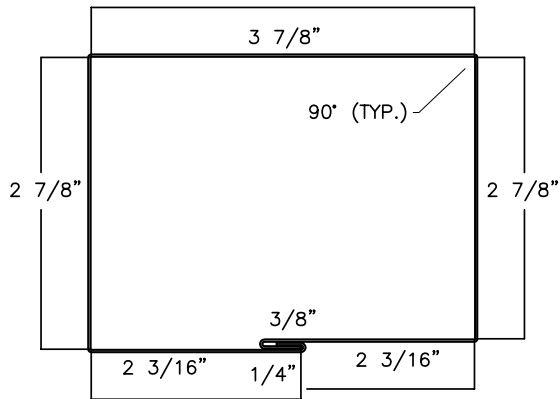

MATERIAL: 3"x14 5/8"

GAUGE	WEIGHT
29	0.17#/FT.
28	0.21# ea.
26	0.25# ea.
24	0.32# ea.

exsteel BUILDING COMPONENTS	7825 Springwater Road Aylmer, Ontario N5H 2R4 519 - 765 - 2244 www.exsteel.com	
	DATE: JAN 24/1990	DRAWN: BVERN
	DATE:	CHECKED:
	DATE:	PROG:
	DATE:	ISSUED:

DESCRIPTION: DOWNSPOUT FLANGE

REV	DESCRIPTION	DATE	BY
1	GENERAL DETAIL REVIEW	JAN 01/09	BJD

DRAWING # M16

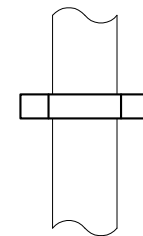
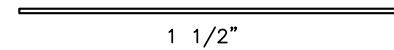

MATERIAL: 1 1/2"x18"

GAUGE	WEIGHT
29	0.17# ea.
28	0.13# ea.
26	0.15# ea.
24	0.20# ea.

exsteel BUILDING COMPONENTS	7825 Springwater Road Aylmer, Ontario N5H 2R4 519 - 765 - 2244 www.exsteel.com	
	DATE: JAN 25/1990	DRAWN: BVERN
	DATE:	CHECKED:
	DATE:	PROG:
	DATE:	ISSUED:

DESCRIPTION: DOWNSPOUT STRAP (M14)

REV	DESCRIPTION	DATE	BY
1	GENERAL DETAIL REVIEW	JAN 01/09	BJD

DRAWING # M17

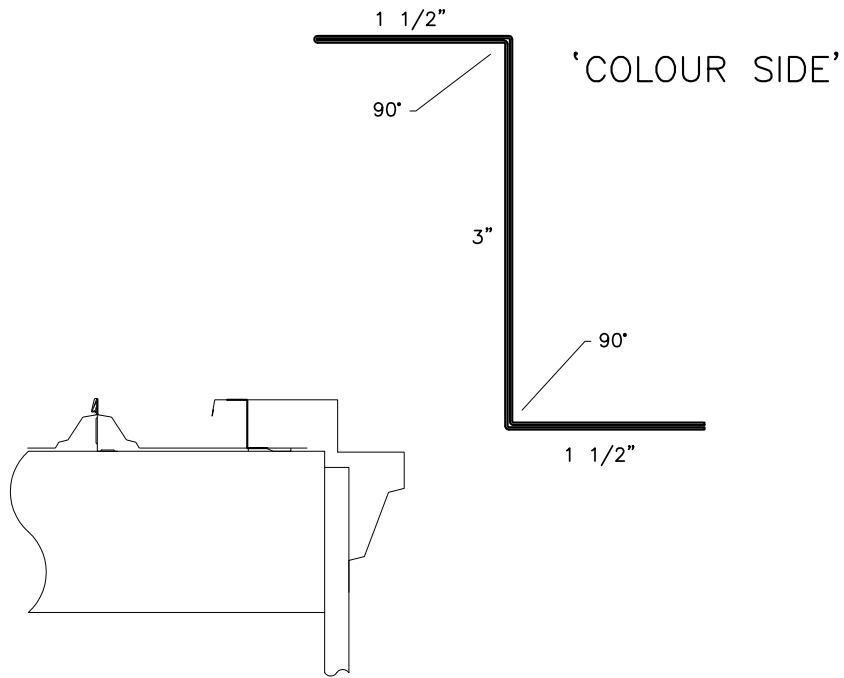

GIRTH: 12"

GAUGE	WEIGHT
29	N/A
28	N/A
26	N/A
24	1.05#/FT.

exsteel BUILDING COMPONENTS		7825 Springwater Road Aylmer, Ontario N5H 2R4 519 - 765 - 2244 www.exsteel.com	
DATE:	FEB 13/1990	DRAWN:	BVERN
DATE:		CHECKED:	
DATE:		PROG:	
DATE:		ISSUED:	
DESCRIPTION: TERMINATION ZEE - RTL-24 - COLOURED			
DRAWING #		M46	
1	GENERAL DETAIL REVIEW	JAN 01/09	BJD
REV	DESCRIPTION	DATE	BY

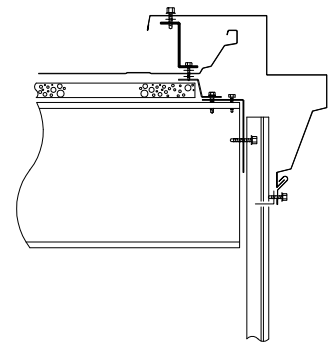
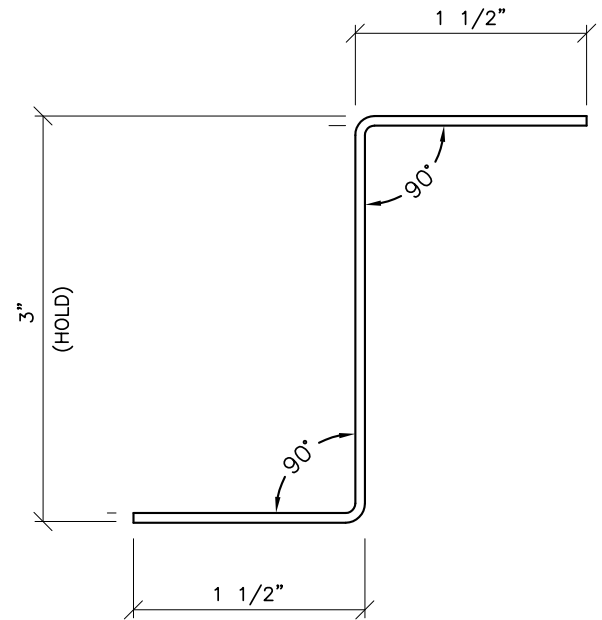

MATERIAL: 6" x 20ga. x 20'-2" (Galv.)
WEIGHT: 15.2# ea.

exsteel BUILDING COMPONENTS		7825 Springwater Road Aylmer, Ontario N5H 2R4 519 - 765 - 2244 www.exsteel.com	
DATE:	APR 05/2004	DRAWN:	IMO
DATE:		CHECKED:	
DATE:		PROG:	
DATE:		ISSUED:	
DESCRIPTION: TERMINATION ZEE - RTL-24			
DRAWING #		RZ242	
1	GENERAL DETAIL REVIEW	JAN 01/09	BJD
REV	DESCRIPTION	DATE	BY

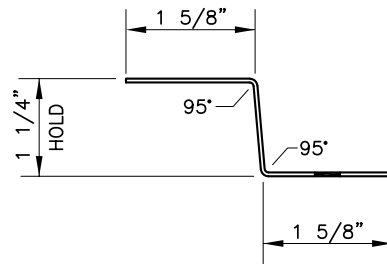
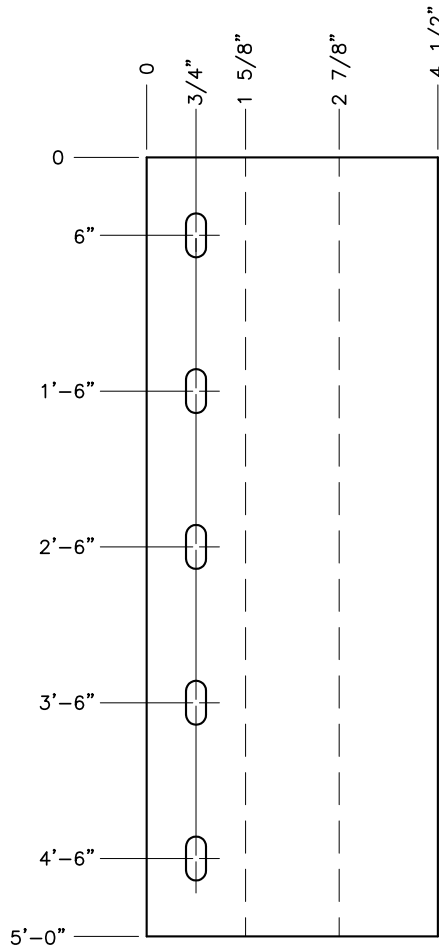

exsteel
BUILDING COMPONENTS

7825 Springwater Road
Aylmer, Ontario N5H 2R4
519 - 765 - 2244
www.exsteel.com

DATE: APR 05/2004	DRAWN: IMO
DATE:	CHECKED:
DATE:	PROG:
DATE:	ISSUED:

DESCRIPTION: SLOTTED HIGH ZEE
PLATE - RTL-24

MATERIAL: 4 1/2"x16ga.x5'-0" GALV.
HOLES: 5 - 11/32"Ø x 2" SLOTS
WEIGHT: 4.69# ea.

REV	DESCRIPTION	DATE	BY
1	GENERAL DETAIL REVIEW	JAN 01/09	BJD

DRAWING # EP250

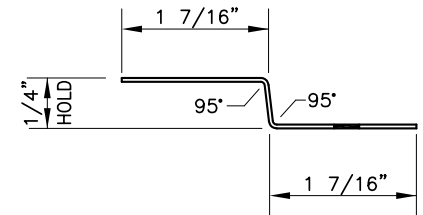
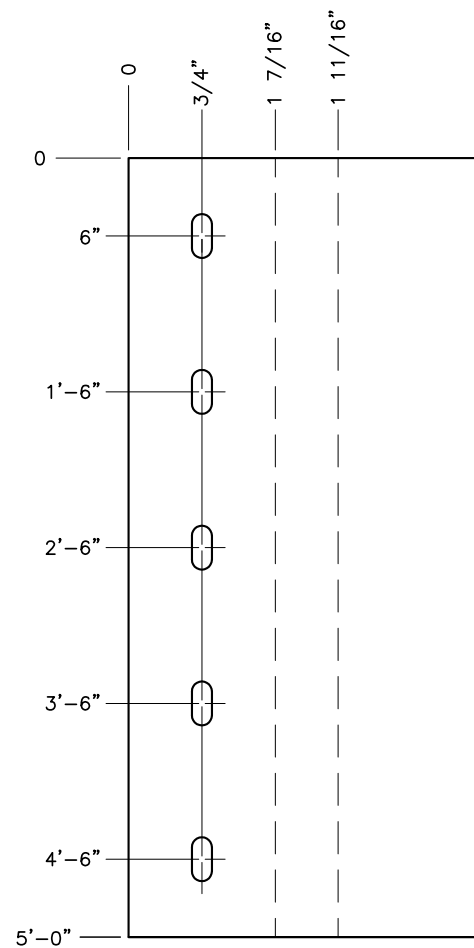

exsteel
BUILDING COMPONENTS

7825 Springwater Road
Aylmer, Ontario N5H 2R4
519 - 765 - 2244
www.exsteel.com

DATE: APR 05/2004	DRAWN: IMO
DATE:	CHECKED:
DATE:	PROG:
DATE:	ISSUED:

DESCRIPTION: SLOTTED LOW ZEE
PLATE - RTL-24

MATERIAL: 3 1/8"x16ga.x5'-0" GALV.
HOLES: 5 - 11/32"Ø x 2" SLOTS
WEIGHT: 3.26# ea.

REV	DESCRIPTION	DATE	BY
1	GENERAL DETAIL REVIEW	JAN 01/09	BJD

DRAWING # EP150

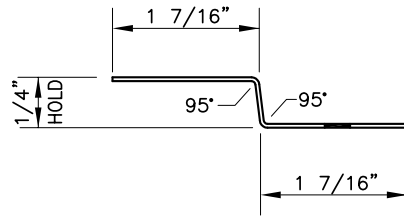
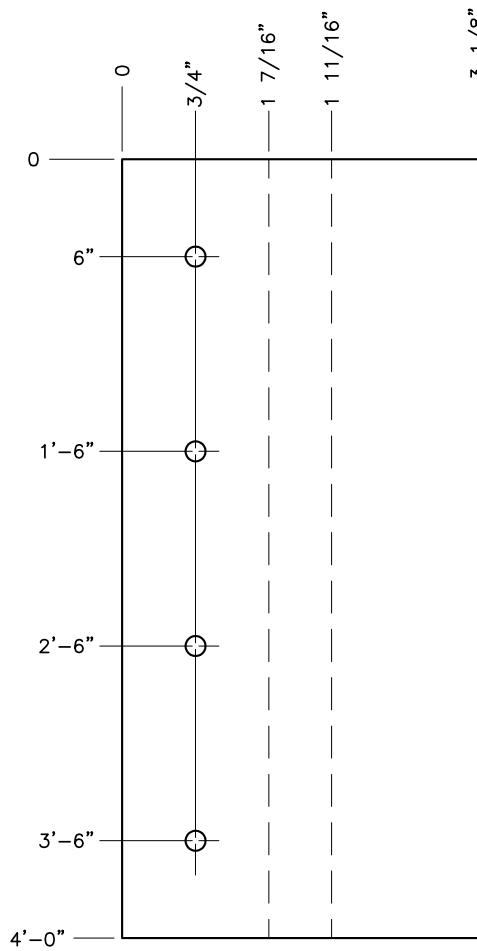

exsteel BUILDING COMPONENTS		7825 Springwater Road Aylmer, Ontario N5H 2R4 519 - 765 - 2244 www.exsteel.com	
DATE:	APR 07/1998	DRAWN:	SB
DATE:		CHECKED:	
DATE:		PROG:	
DATE:		ISSUED:	
DESCRIPTION:		LOW ZEE PLATE - RTL-24	
DRAWING #		EP140	
1	GENERAL DETAIL REVIEW	JAN 01/09	BJD
REV	DESCRIPTION	DATE	BY

MATERIAL: 3 1/8"x16ga.x4'-0" GALV.
 HOLES: 4 - 5/16"Ø
 WEIGHT: 2.6# ea.

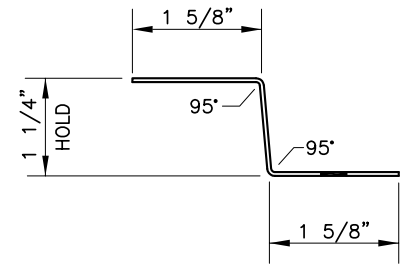
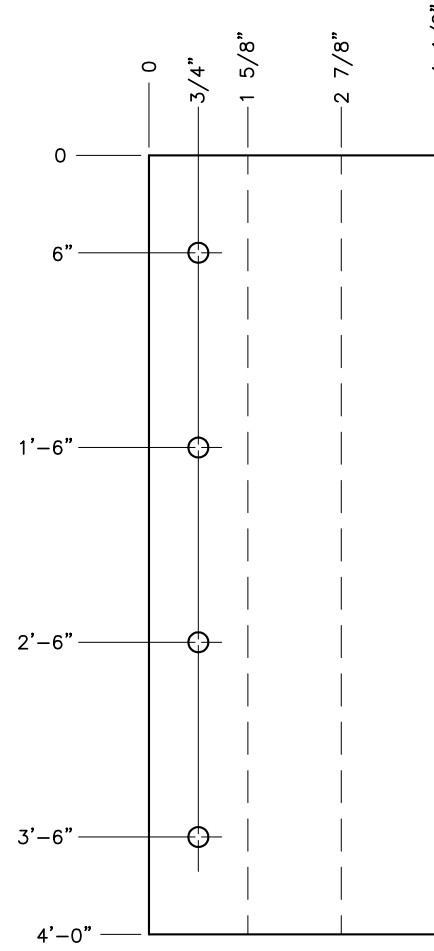

exsteel BUILDING COMPONENTS		7825 Springwater Road Aylmer, Ontario N5H 2R4 519 - 765 - 2244 www.exsteel.com	
DATE:	MAR 13/2001	DRAWN:	SB
DATE:		CHECKED:	
DATE:		PROG:	
DATE:		ISSUED:	
DESCRIPTION:		HIGH ZEE PLATE - RTL-24	
DRAWING #		EP240	
1	GENERAL DETAIL REVIEW	JAN 01/09	BJD
REV	DESCRIPTION	DATE	BY

MATERIAL: 4 1/2"x16ga.x4'-0" GALV.
 HOLES: 4 - 5/16"Ø
 WEIGHT: 3.75# ea.